



COLTRI SUB

Special equipment and compressors for underwater activities

High Pressure Compressors

MCH 13-16/ETC

MCH 13-16/ET

MCH 8/EM **STANDARD** **MCH 13-16/SH**

MCH 13-16/DY

MCH 13-16/DH

VERSION: English

INSTRUCTION

MANUAL



USE IN BRIEF

Use in brief	7
--------------------	---

1

GUARANTEE AND ASSISTANCE

1.1 Guarantee	11
1.2 Assistance	11

2

TECHNICAL DESCRIPTION

2.1 Operating principle	14
2.2 Description of the pump unit	15
2.2.1 Monobloc unit	16
2.2.2 Head unit	17
2.2.3 Safety valves	17
2.2.4 Lubricating unit	18
2.2.5 Pressure maintenance valve	18
2.2.6 Cooling pipes	18
2.2.7 Filters	19
2.2.8 Frame and sound-proofed casing	20
2.3 Machine control	21

3

TECHNICAL CHARACTERISTIC

3.1 Technical characteristics of the pump unit	22
3.1.1 STANDARD series of refill stations	23
3.1.2 Sizes and weights	24
3.2 Noise	25

4

PRECAUTIONS FOR USE AND MAINTENANCE

4.1 Machine area diagrams	26
4.1.1 Safety devices	27
4.1.2 Residual risk areas	29



UNPACKING AND HANDLING THE MACHINE

5

5.1	Unpacking the machine	30
5.2	Pack contents	30
5.3	Handling the machine	31

INSTALLATION

6

6.1	Positioning	32
6.2	Connections	33
6.2.1	Connecting the air intake extension	33
6.2.2	Connecting the refill hoses	35
6.2.3	Electrical connection for models MCH 8/EM - MCH 13-16/ETC - MCH 13-16/ET	36

CONTROL PANEL

7

7.1	Control panel	38
7.1.1	Wall-mounted control panel for models with electric power supply (optional)	39
7.1.2	Controls on board the internal combustion engines	40
7.2	Indication and control devices	41

START AND STOP

8

8.1	Filling the machine	42
8.2	Checks	44
8.2.1	Models with electric power supply	44
8.2.2	Models with petrol supply	46
8.2.3	Models with diesel fuel supply	50
8.2.4	Stopping the internal combustion engine	55

USE

9

9.1	Preliminary operations	57
9.2	Refilling the cylinders	58



10

PUTTING THE MACHINE OUT OF OPERATION AND DISMANTLING THE MACHINE

10.1	Instructions for prolonged machine standstills	62
10.2	Disposal of waste products	66
10.3	Dismantling the machine	66

11

MAINTENANCE

11.1	General notes	69
11.2	Preventive maintenance	69
11.3	Changing the lubricant oil	70
11.4	Checking the transmission belt	71
11.5	Air intake filter	73
11.6	Active carbon filter and molecular sieve	74
11.7	Refill hose	76
11.8	Intake and discharge valves	77
11.9	Heads	77
11.10	Cylinders	78
11.11	Internal combustion engines	79
11.11.1	Maintenance programme	79
11.11.2	Oil change	80
11.11.3	Air filter	81
11.11.4	Sediment sump (only for petrol engines)	82
11.11.5	Spark plugs (only for petrol engines)	83
11.11.6	Minimum carburettor regulation (only petrol engines)	85
11.11.7	Fuel filter	85
11.11.8	Battery 12 Volt (not supplied by Aerotecnica Coltri)	86
11.2	Maintenance operations	88

12

TROUBLESHOOTING

12.1	List of faults	90
------	----------------------	----



MACHINE DIAGRAMS

13

13.1	Compression diagram	92
13.2	Electricals diagrams	93

SPARE PARTS

14

14.1	Exploded view of the machine parts	95
	Monobloc	96
	Pistons rod unit	98
	Cylinders unit	100
	Head unit	102
	Cooling pipes	104
	Filtering system	106
	Condensate trap	108
	MCH 13-16/ETC	110
	MCH 13-16/ET	112
	MCH 8/EM	114
	MCH 13-16/SH	116
	MCH 13-16/DY	118



To make the manual easier to read, the following terms have been adopted:

DANGER



The term **DANGER** is used when failure to comply with the regulations or tampering with the parts could lead to serious injury or even death.

WARNING



The term **WARNING** is used when failure to comply with the instructions could cause damage to the machine and other parts associated with the same or to the surrounding area.

LABEL APPLIED TO THE COMPRESSORS

AEROTECNICA COLTRI S.r.l.		
Via Colli Storici, 177		
25010 S. Martino d/Battaglia (BS) Italy		
Tel. 030/9910297-9910301		
Fax 030/9910283		
MODEL	<input type="text"/>	
TYPE	<input type="text"/>	
S/N	<input type="text"/>	
YEAR	<input type="text"/>	
MOTOR	<input type="text"/>	
POWER	<input type="text"/>	

To protect exposed persons or objects, a special booklet entitled “**SAFETY REGULATIONS**” is supplied with the machine and must be considered an integral part of the Compressor Instruction Manual.

Editor’s note: This manual refers specifically to the “**STANDARD**” series of refill stations which, as later explained, may be supplied in various arrangements although they all work on the same operating principle.

For this reason, the illustrations given in the Instruction Manual should be considered only as indications insofar as they refer to just one version of refill station in the “**STANDARD**” series.

This manual is the property of **AEROTECNICA COLTRI S.r.l.** and any copying of the same, even partial, is prohibited.



USE IN BRIEF

The following information must be referred to and applied only when this manual and the “Safety regulations” manual have been read and their contents have been understood and assimilated.



VERSION WITH ELECTRIC ENGINE

- Check whether or not the area where the machine is installed has suitable ventilation (see chapter 6.1).
- If the machine is installed in a place without the required characteristics above, connect the air intake extension (see chapter 6.2.1).
- Connect the refill hoses to the machine (see chapter 6.2.2).
- Connect the switchboard to the mains power supply (see chapter 6.2.3).
- Check the level of the lubricating oil in the pump unit (see chapter 8.2). If the level is too low, turn off the machine and add or change the oil (see chapter 8.1).
- Turn on the machine using the main switch (see chapter 7.1).
- Check the direction of rotation of the motor. If the direction of rotation does not coincide with the one shown on the belt guard, turn off the machine and invert the two phases on the main power supply (see chapter 7.2).
- Check the operation of the safety valve (see chapter 9.1).
- Check for wear on the cylinders to be filled (see chapter 9.1).
- Set the pressure switch on the control panel to the refill pressure value given on the cylinder (see chapter 8.1).
- Fit the hose attachment on the cylinder and check that the taps on the hose are open (see chapter 9.2).
- Turn on the cylinder tap and start up the compressor (see chapter 9.2).
- When the filling operation has been completed, the compressor is stopped automatically by the pressure switch, turn off the cylinder and the hose taps.
- Press the pressure bleed button and disconnect the cylinder attachment (see chapter 9.2).



USE IN BRIEF



The following information must be referred to and applied only when this manual and the “Safety regulations” manual have been read and their contents have been understood and assimilated.

VERSION WITH PETROL ENGINE

- Check whether or not the area where the machine is installed has suitable ventilation (see chapter 6.1).
- If the machine is installed in a place without the required characteristics above, connect the air intake extension (see chapter 6.2.1).
- Connect the refill hoses to the machine (see chapter 6.2.2).
- Check the level of the lubricating oil in the pump unit (see chapter 8.2). If the level is too low, turn off the machine and add or change the oil (see chapter 8.1).
- Check the oil level of the internal combustion engine using the dipstick provided (see chapter 11.11.2).
- Add fuel to the tank (unleaded petrol of the recommended type).
- Check the operation of the safety valve (see chapter 9.1).
- Check for wear on the cylinders to be filled (see chapter 9.1).
- Fit the hose attachment on the cylinder and check that the taps on the hose are open (see chapter 9.2).
- Turn on the cylinder tap and start up the compressor (see chapter 9.2).
- When the filling operation has been completed, the compressor is stopped automatically by the pressure switch, turn off the cylinder and the hose taps.
- Press the pressure bleed button and disconnect the cylinder attachment (see chapter 9.2).
- Move the fuel lever to the “open” position (in an anti-clockwise direction).
- Move the air lever to the “closed” position (in a clockwise direction).
- Turn the accelerator lever slightly in an anti-clockwise direction.

ENGINE WITH PULL START

- Move the engine start switch to the “ON” position.
- Pull the starter cord until a certain resistance is felt, then pull hard.

ENGINE WITH ELECTRIC START

- Move the engine start switch to the “START” position and keep it in this position until the engine starts up.



STOPPING THE ENGINE

In an emergency, simply move the engine switch to the “OFF” position.



To stop the engine under normal circumstances:

- turn the accelerator lever in an anti-clockwise direction as far as it will go;
- move the engine switch to “OFF”;
- move the fuel lever to “OFF” (in a clockwise direction).



USE IN BRIEF



The following information must be referred to and applied only when this manual and the “Safety regulations” manual have been read and their contents have been understood and assimilated.

VERSION WITH DIESEL ENGINE

- Check whether or not the area where the machine is installed has suitable ventilation (see chapter 6.1).
- If the machine is installed in a place without the required characteristics above, connect the air intake extension (see chapter 6.2.1).
- Connect the refill hoses to the machine (see chapter 6.2.2).
- Check the level of the lubricating oil in the pump unit (see chapter 8.2). If the level is too low, turn off the machine and add or change the oil (see chapter 8.1).
- Check the oil level in the diesel motor using the dipstick provided (see chapter 11.11.2).
- Add fuel to the tank (diesel fuel of the recommended type).
- Check the operation of the safety valve (see chapter 9.1).
- Check for wear on the cylinders to be filled (see chapter 9.1).
- Fit the hose attachment on the cylinder and check that the taps on the hose are open (see chapter 9.2).
- Turn on the cylinder tap and start up the compressor (see chapter 9.2).
- When the filling operation has been completed, the compressor is stopped automatically by the pressure switch, turn off the cylinder and the hose taps.
- Press the pressure bleed button and disconnect the cylinder attachment (see chapter 9.2).
- Move the fuel lever to the “open” position (in an anti-clockwise direction).
- Turn the accelerator lever to the “START” position.

ENGINE WITH PULL START

- Slowly pull the starter cord until a certain resistance is felt.
- Release the cord slowly. Press the decompression lever downwards. Grip the handle tightly and pull the cord firmly. Use both hands if necessary.

ENGINE WITH ELECTRIC START

- Turn the engine starter key to the “START” position and keep it in this position until the engine starts up.
- Release the key as soon as the engine starts up.



GUARANTEE AND ASSISTANCE

1

Guarantee

1.1

AEROTECNICA COLTRI S.r.l. guarantees its compressors against any design or manufacturing defect or fault and against any fault in the materials for a period of twelve months from the delivery of the machine. The customer must inform **AEROTECNICA COLTRI S.r.l.** in writing of any fault and/or defect that may be found within eight days from its discovery by means of a registered letter with advice of receipt or telegramme, otherwise the guarantee will become null and void.

The guarantee is only valid against faults or defects that may arise with the compressor used under proper operating conditions according to the instructions given in this manual and with the maintenance carried out at the intervals as provided for.

The guarantee expressly excludes any faults arising as a result of improper use of the machine, of atmospheric agents and of damage due to transport; the guarantee does not cover the expendable materials and materials required for the periodic maintenance which are at the customer's entire expense. The guarantee will, in any case, become automatically null and void if the compressor is tampered with or if it has been serviced by technicians who are not authorized to do so by **AEROTECNICA COLTRI S.r.l.**

Any compressor that is acknowledged to be faulty due to defects in the design, manufacturing or materials used, will be repaired or replaced free of charge by **AEROTECNICA COLTRI S.r.l.** at its factory in San Martino della Battaglia (BRESCIA). The customer will be responsible for the costs of transport and carriage as well as for any spare parts and expendable materials.

If it should be necessary for service to be carried out under the guarantee at the customer's premises, the latter will be responsible for the travel and transfer costs for the staff sent out by **AEROTECNICA COLTRI S.r.l.**

Taking delivery of the machine and/or of any faulty components or the transfers for the inspection of faults and/or defects as notified by the customer, will not, however, denote any implicit acknowledgement regarding the effectiveness of the guarantee.

Repairs and/or replacements made by **AEROTECNICA COLTRI S.r.l.** during the guarantee period will not extend the duration of the same.

Acknowledgment of the guarantee does not itself imply any liability for compensation on the part of **AEROTECNICA COLTRI S.r.l.**

AEROTECNICA COLTRI S.r.l. does not assume any responsibility for injury to persons or damage to property or for any other direct or indirect damage (loss of production or missed profit, etc.) that may be attributable to faults or defects of the compressor, except for those cases in which a serious fault can be attributed to the company.

Assistance

1.2

The **AEROTECNICA COLTRI S.r.l.** technicians are available for any kind of routine or additional maintenance work.

The request for technical assistance must be sent to **AEROTECNICA COLTRI S.r.l.** at the following address:

AEROTECNICA COLTRI S.r.l.

Via Colli Storici, 177

25010 San Martino della Battaglia (BRESCIA) ITALIA

Fax: +39 030 9910283

e-mail: coltrisub@coltrisub.it



2

TECHNICAL DESCRIPTION



This chapter provides a technological description of the machine and its main components.

2.1	Operating principle	14
2.2	Description of the pump unit	15
	2.2.1 Monobloc unit	16
	2.2.2 Head unit	17
	2.2.3 Safety valves	17
	2.2.4 Lubrication unit	18
	2.2.5 Pressure maintenance valve	18
	2.2.6 Cooling pipes	18
	2.2.7 Filters	19
	2.2.8 Frame and sound-proofed casing	20
2.3	Machine control	21

The “**Standard**” series of refill stations can be supplied in versions that run on electric single or three-phase inputs, petrol or diesel fuel.

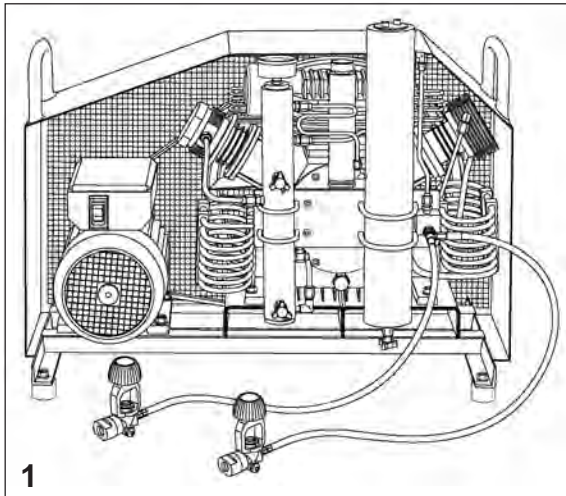

- MCH 8/EM STANDARD (Fig. 1) Electric single phase;

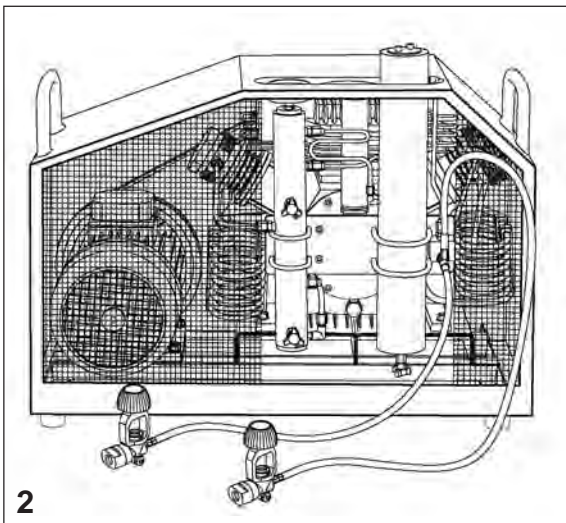

- MCH 13-16/ETC STANDARD (Fig. 2) Electric three-phase;

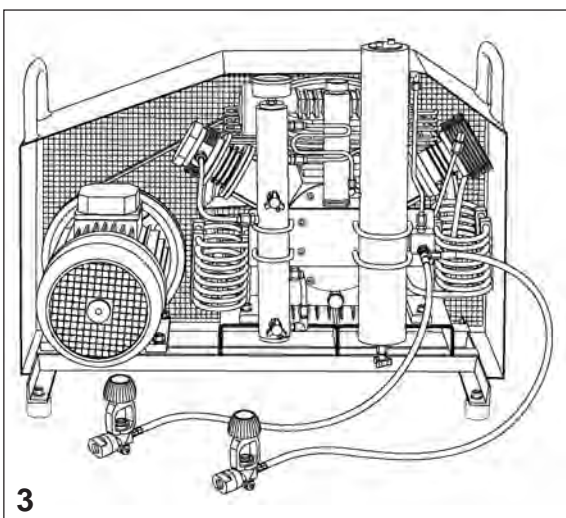

- MCH 13-16/ET STANDARD (Fig. 3) Electric three-phase;

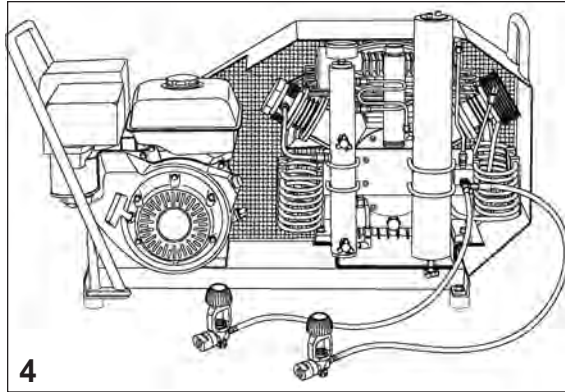

- MCH 13-16/SH Petrol (Fig. 4) (HONDA engine);

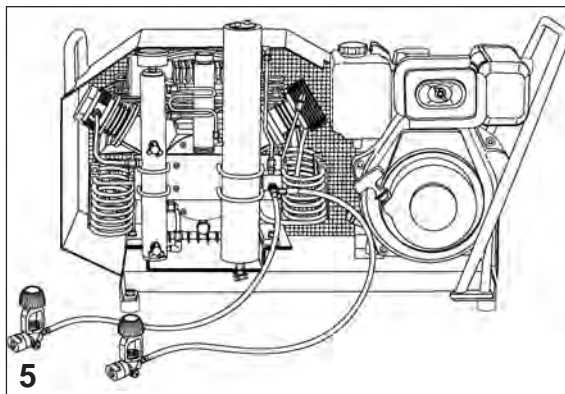

- MCH 13-16/DY Diesel (Fig. 5) (YANMAR engine);

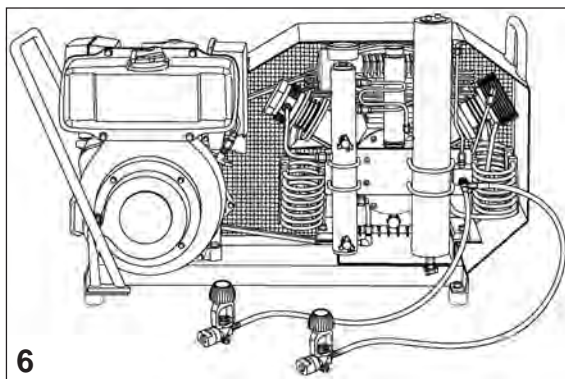

- MCH 13-16/DH Diesel (Fig. 6) (HONDA engine).

2.1 **Operating principle**

All the compressors fitted inside the refill stations are of the high pressure type with forced air cooling and 3 stages of compression. The air circulating around the compressor, which does not contain any harmful fumes, is taken into the intake filter and introduced through the intake valve into the cylinder of the first stage where the first compression takes place.

A part of the heat produced in the compression is dissipated by the flow of air created by the fan through the head and relative valves, piston, cylinder, monobloc and lubricating oil; the heat remaining in the compressed air is dissipated in the long piping connecting one stage of the compression to another and which acts as a radiator; the temperature at the hose outlet is just a few degrees higher than that of the environment.

The operating temperatures of each stage are: at the pipe connection that goes to the intake cylinder: about 15-20 °C above the environmental temperature (it feels warm to the touch), to the pipe connection that starts from the head (from the discharge valve), about 80-100 °C.

The intake air contains a certain degree of humidity according to atmospheric conditions. During the compression and subsequent cooling, the humidity condenses and together with the particles of lubricating oil forms a milky white emulsion that precipitates into the separators.

The compression diagram is included in chapter 13.

Description of the pump unit

2.2

The pumping unit has the task of producing compressed air at high pressure (200-300 bar) and purifying it by means of the decantation and filtering systems until it reaches a level of purity equal to or higher than the limits set by the standards DIN 3188 - UNI EN 132 - CGA/E, or to increase the pressure of the gas inhaled (only inert - non-explosive gases).

This unit consists of the following components (Fig. 7-8):

Table 1

N°	Description	N°	Description
1	Intake filter	12	2 nd stage safety valve
2	1 st stage head	13	Monobloc
3	2 nd stage head	14	Filter-holding bracket
4	3 rd stage head	15	Fan
5	1 st stage cylinder	16	Oil cap
6	2 nd stage cylinder	17	Final condensate separator
7	3 rd stage guiding cylinder	18	Condensate separator between stages
8	1 st -2 nd stage cooling pipe	19	Condensate discharge connection
9	2 nd -3 rd stage cooling pipe	20	Maintenance valve
10	Final cooling pipe	21	Pipe-fastening bracket
11	1 st stage safety valve	22	3 rd stage or final safety valve

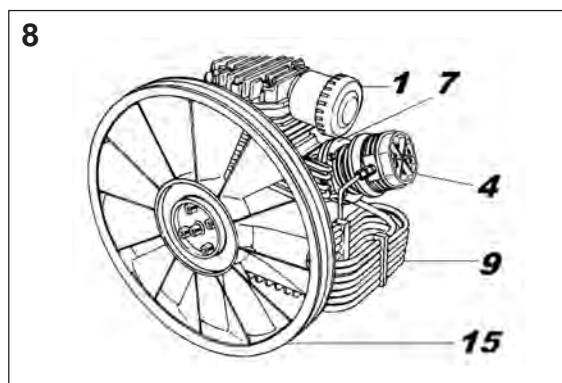
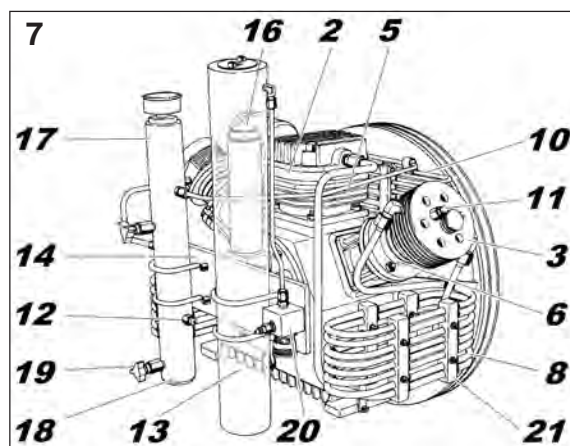



2.2.1

Monobloc unit

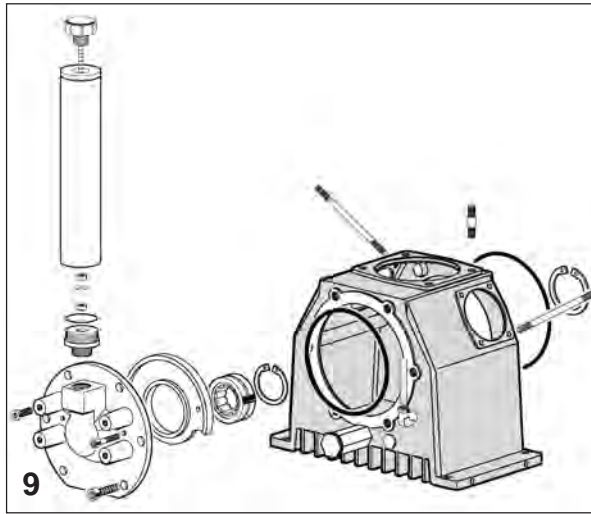

The gooseneck, the pistons and the cylinders also form a part of this unit.

The monobloc (Fig. 9) is made of aluminium alloy, the two flanges with the ball and roller bearings that support the gooseneck are oil-tight with the monobloc due to the O-Rings fitted.

The gooseneck and the connecting rods only turn on roller or ball bearings (Fig. 10).

The three connecting rods are fitted on the gooseneck with a single crank angle.

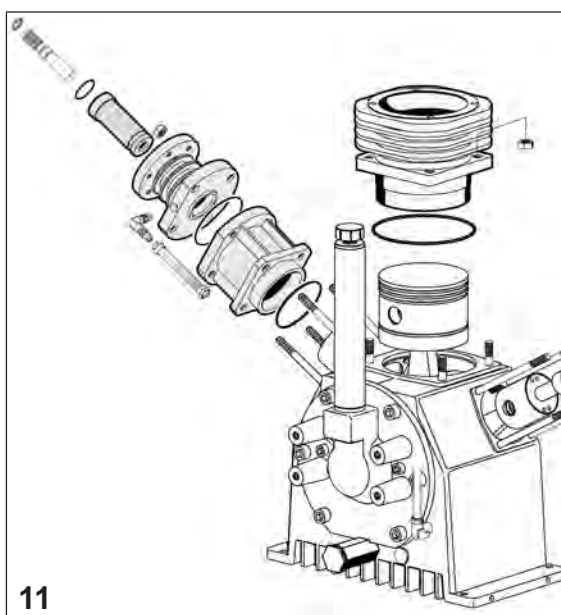
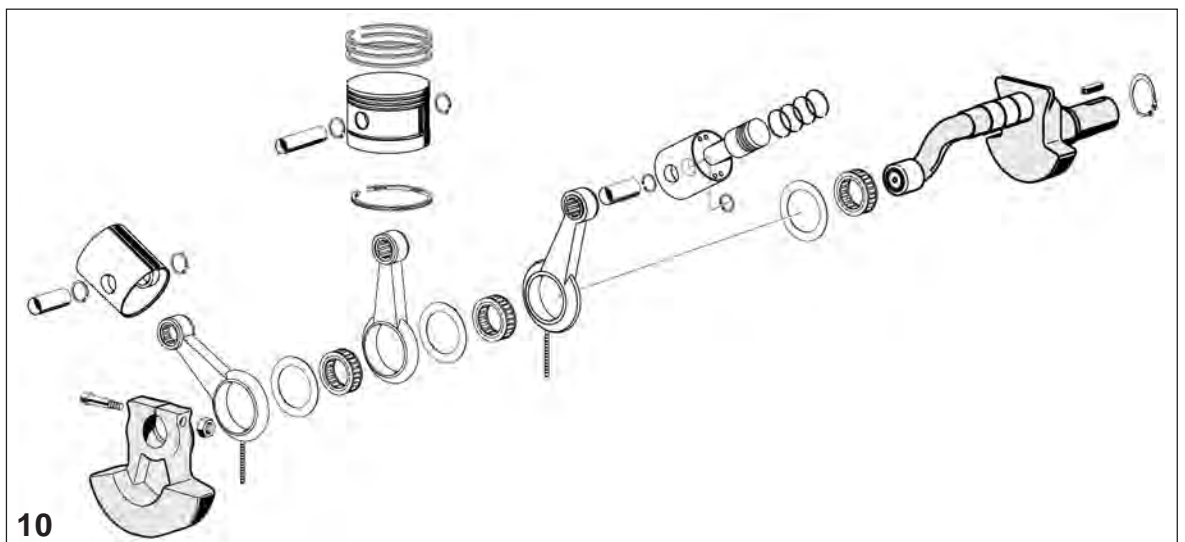

The cylinders are made of cast iron (Fig. 11), while the pistons are made of aluminium and have traditional multiple compression rings. The high pressure stage piston has an anti-wear coating. The relative cylinder is given a self-lubricating treatment.

Head unit (Fig. 12)

2.2.2

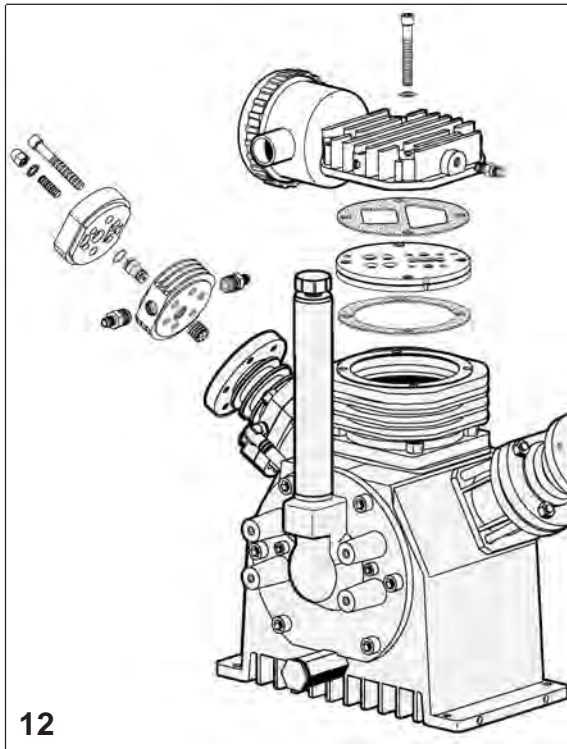

The head unit includes the discharge and intake valves.

The head of the 1st stage is of a lamellar type and includes both the intake and the discharge.

The intake and discharge valves are located directly in their threaded seats of the heads of the 2nd and 3rd stages.

The intake valves can be removed using the special pin wrench (cod. SC000480), having first removed the heads.

The discharge valves can be removed from the outside.

See Chapter 11, "Maintenance".

Safety valves

2.2.3

The purpose of the safety valves (see figure 7) is to protect the machine (and the cylinders) from overpressure.

These valves are pre-calibrated in the factory at the following pressures:

- safety valve for 1st stage: 8 bar;
- safety valve for 2nd stage: 50 bar;
- safety or final valve for 3rd stage: 225 bar - or 330 bar.

WARNING

Under no circumstances may these valves be altered to increase the calibrated pressure.

If these valves should come into operation, check the cause that has led to the maximum pressure and take steps according to the instructions given in paragraph 12.1.

Any tampering with the safety valves causes serious damage and an immediate cancellation of the guarantee.





2.2.4 Lubricating unit

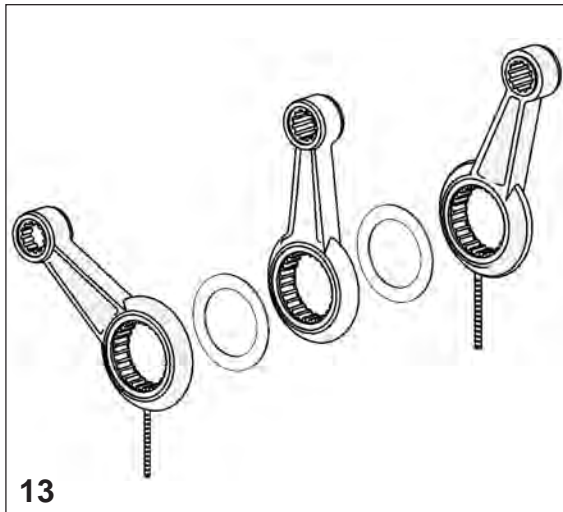

Lubrication is carried out by means of a tang screwed into the end part of the connecting rods of the 2nd and 3rd stages (Fig. 13).

The 3rd high pressure stage is lubricated by oil vapours.

2.2.5 Pressure maintenance valve

This valve is fitted after the final filter. Just a few seconds after the compressor has been started up, it keeps the pressure of the entire system at 100 ± 20 bar (see exploded view Chapter 14), for the purpose of eliminating as much water as possible from the air. It also acts as a non-return valve.

2.2.6 Cooling pipes (Fig. 14)

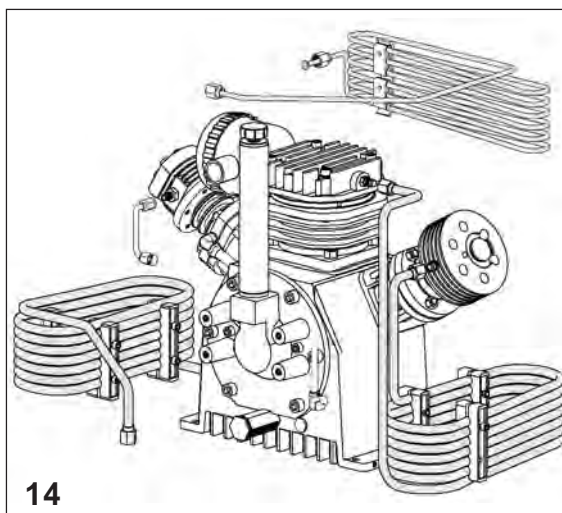

The cooling pipes between the 1st and 2nd stage, between the 2nd and 3rd stage and after the 3rd stage are made of stainless steel, like those for the passage of air between the separator and the filter.

Filters

2.2.7

INTAKE FILTER (Fig. 15)

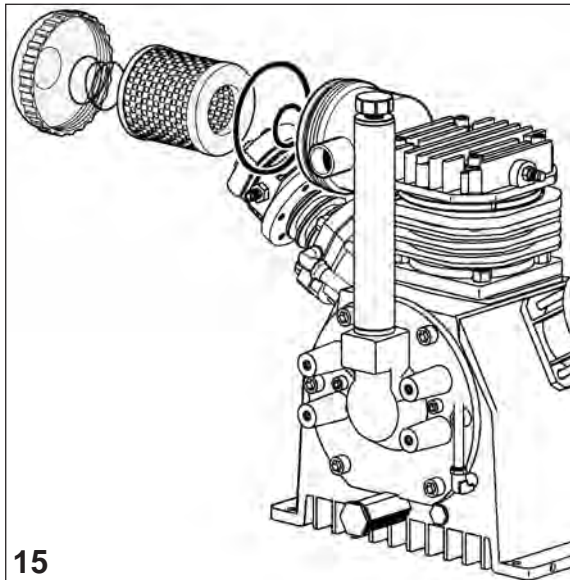

The suction filter is coupled directly to the lid of the 1st stage head.

The intake filter consists of a cylindrical aluminium casing provided with a screw cap that holds the filtering cartridge.

A special attachment is provided on the filter for the connection of an extension (optional) which enables air to be taken from the outside when the compressor is installed in a place without ideal ventilation.

For the compressor to operate properly, the filter maintenance must be carried out as provided for and at the intervals recommended (instructions in paragraph 11.6).

ACTIVE CARBON AND MOLECULAR SIEVE FILTER (Fig. 16)

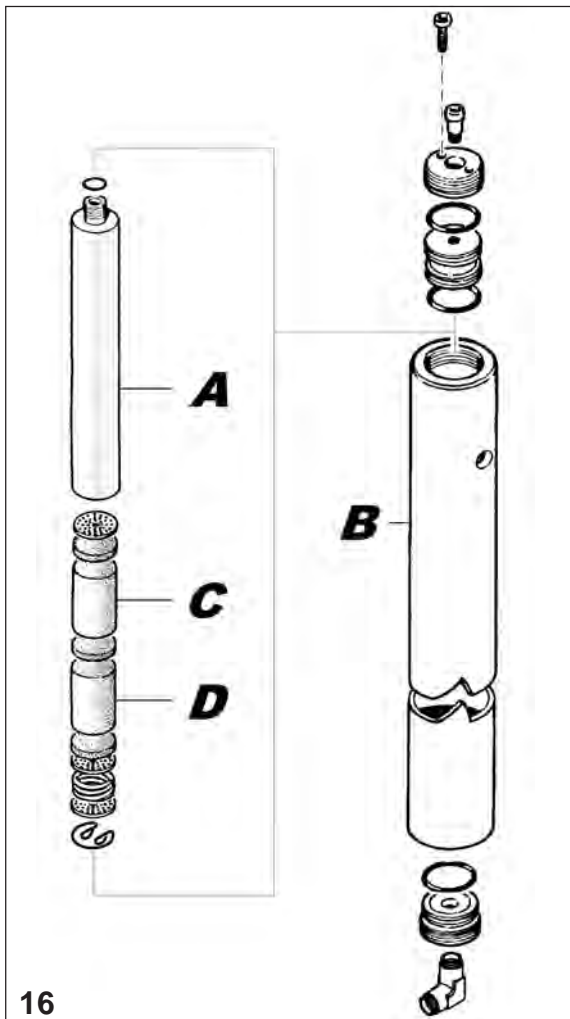

The filter consists of an aluminium tube (B) that holds the filter cartridge (A).

The shell of the cartridge contains the active carbon (C) and the molecular sieve (D) placed between felt disks.

The condition of the cartridge is of fundamental importance for the quality of the air (see paragraph 11.7 for replacement instructions).



2.2.8

Frame

MCH 13-16/ETC FRAME

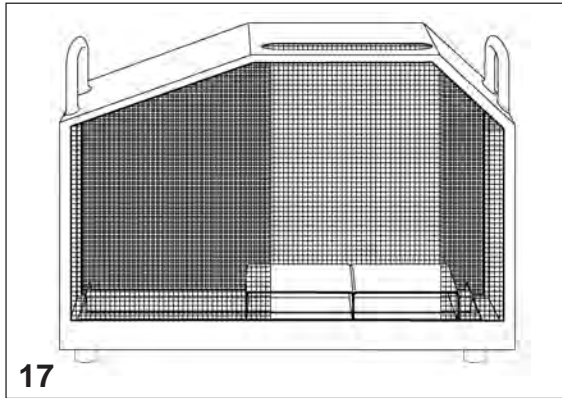

MCH 8/EM - MCH 13-16/ET FRAME

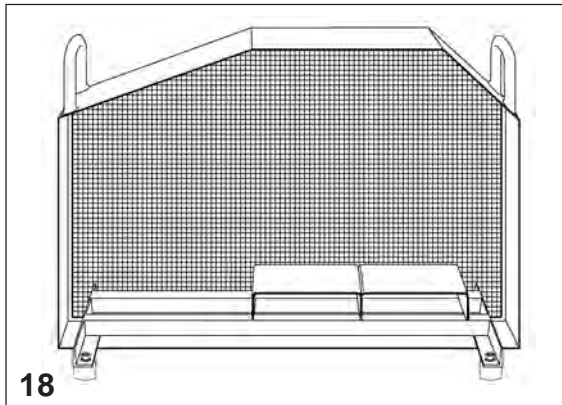

MCH 13-16/DY FRAME

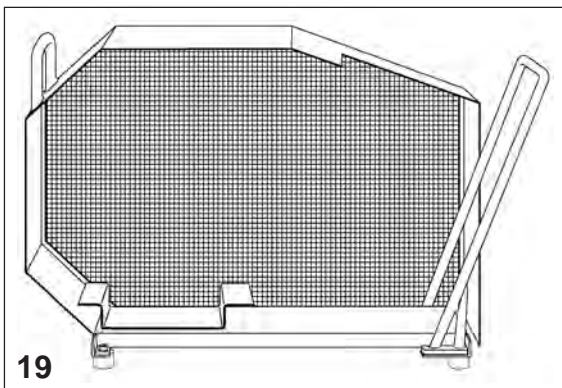

MCH 13-16/SH - MCH 13-16/DH FRAME

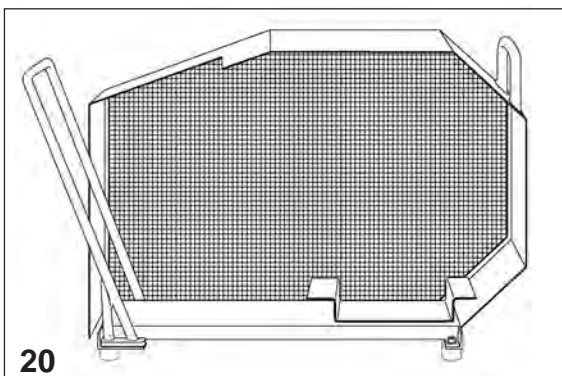

The compressor and the engine (electric or internal combustion) are fitted on a welded steel frame coated with epoxy resins.

The frame consists of a coated guard and is fitted with handles to be able to move the refill station more easily.

For the various models, the frames produced are of 3 types that can be considered to be similar to each other:

- a) frame for models MCH 13-16/ETC (Fig. 17);
- b) frame for models MCH 8/EM and MCH 13-16/ET (Fig. 18);
- c) frame for models MCH 13-16/DY (Fig. 19);
- d) frame for models MCH 13-16/SH and MCH 13-16/DH (Fig. 20).

Machine control

2.3

The refill stations in the “**Standard**” series do not have an actual control panel as such.

For the models with an **electric engine**, a cable is provided for connection to the purchaser’s mains electricity supply (this cable should guarantee that the installation complies with the standards in force concerning such matters in the country of installation).

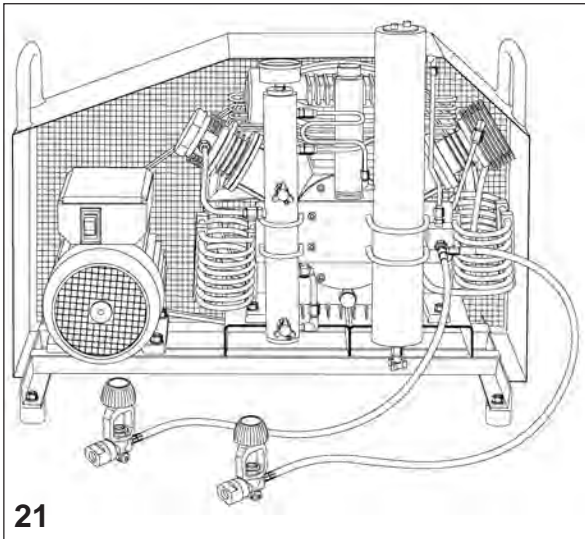

The Standard model MCH 8/EM is also provided with an “ON/OFF” switch (Fig. 21).

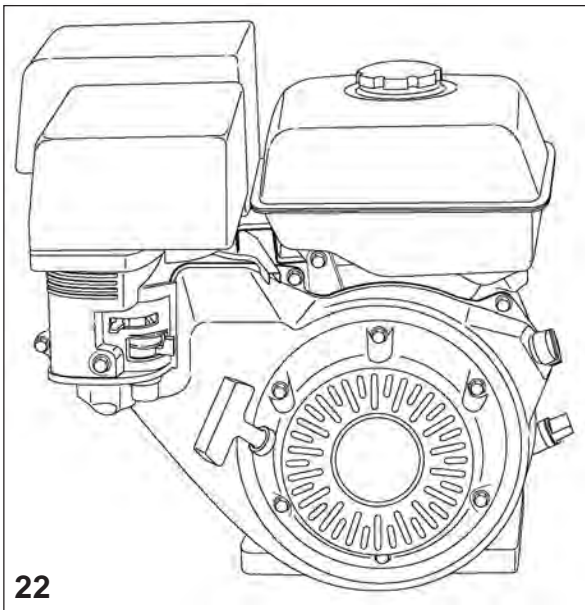

For the models with an **internal combustion engine**, the operating controls are all on-board the engine and enable the refill station to be started up and also to regulate the speed according to requirements (Fig. 22).



3

TECHNICAL CHARACTERISTIC



This chapter provides some technical information concerning the machine.

3.1	<i>Technical characteristics of the pump unit</i>	<i>22</i>
	3.1.1 <i>STANDARD series of refill stations</i>	<i>23</i>
	3.1.2 <i>Sizes and weights</i>	<i>24</i>
3.2	<i>Noise</i>	<i>25</i>

3.1

Technical characteristics of the pump unit

The pump unit consists of: three compression stages, three cylinders, forced air cooling by means of a large diameter fan, splash lubrication with immersed tangs, stainless steel cooling pipes.



STANDARD series of refill stations
3.1.1

Table 1

	MCH 8/EM	MCH 13/ETC	MCH 16/ETC	MCH 13/ET	MCH 16/ET	MCH 13/SH	MCH 16/SH	MCH 13/DY	MCH 16/DY	MCH 13/DH	MCH 16/DH
Max. non-continuous peak pressure	225 or 330 bar 3200 or 4700 psig										
Max. non-continuous working pressure	225 or 330 bar 3200 or 4700 psig										
Capacity	approx. 135 lt/min 8 m ³ /h	approx. 210 lt/min 13 m ³ /h	approx. 260 lt/min 16 m ³ /h	approx. 520 lt/min 32 m ³ /h	approx. 260 lt/min 16 m ³ /h	approx. 210 lt/min 13 m ³ /h	approx. 260 lt/min 16 m ³ /h	approx. 210 lt/min 13 m ³ /h	approx. 260 lt/min 16 m ³ /h	approx. 210 lt/min 13 m ³ /h	approx. 260 lt/min 16 m ³ /h
Cylinder diameter	88/36/14 mm		95/38/14 mm	88/36/14 mm	95/38/14 mm	88/36/14 mm	95/38/14 mm	88/36/14 mm	95/38/14 mm	88/36/14 mm	95/38/14 mm
Speed of rotation	890 r.p.m.	1350 r.p.m.	1550 r.p.m.	1550 r.p.m.	1550 r.p.m.	1350 r.p.m.	1550 r.p.m.	1350 r.p.m.	1550 r.p.m.	1350 r.p.m.	1550 r.p.m.
Piston stroke	40 mm										
Intermediate pressures	1 st stage 5 bar/70 psig 2 nd stage 40 bar/570 psig 3 rd stage 225-330 bar/3200-4700 psig										
Power motor	3kW - 4Hp Electric	4kW - 5,5Hp Electric	5,5kW - 7,5Hp Electric	4kW - 5,5Hp	5,5kW - 7,5Hp Petrol	6,6kW - 9Hp Petrol	6,6kW - 9Hp Petrol	6,6kW - 9Hp Diesel Yanmar	6,6kW - 9Hp	6,6kW - 9Hp Diesel	6,6kW - 9Hp Honda
Tension and frequency	SINGLE PHASE 230V - 50Hz 230V - 60Hz					THREE-PHASE		400V - 50Hz 230V - 50Hz 230V - 60Hz 660V - 50Hz			

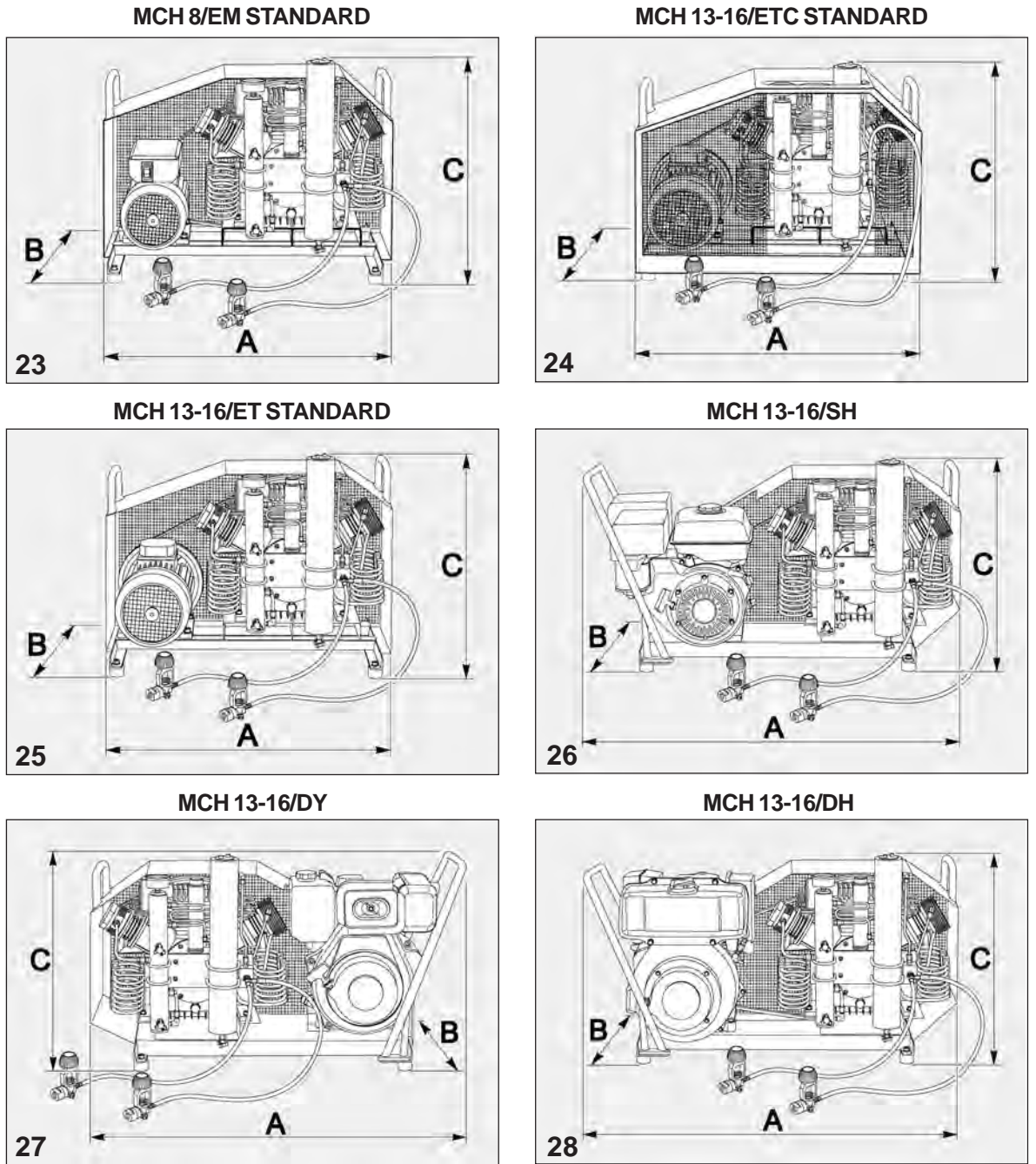

3.1.2 Sizes and weights (Fig. 23÷28)



MODEL	A (mm)	B (mm)	C (mm)	Weight (Kg.)
MCH 8/EM Standard	855	450	635	99
MCH 13/ETC Standard	855	475	665	126
MCH 16/ETC Standard	855	475	665	136
MCH 13/ET Standard	850	450	635	99
MCH 16/ET Standard	850	450	635	109
MCH 13-16/SH	1130	470	635	115
MCH 13-16/DY	1140	500	640	155
MCH 13-16/DH	1105	490	650	148

Table 2



Noise

3.2

The “Standard” series of compressors have been designed and built with the objective of reducing acoustic pressure to a minimum.

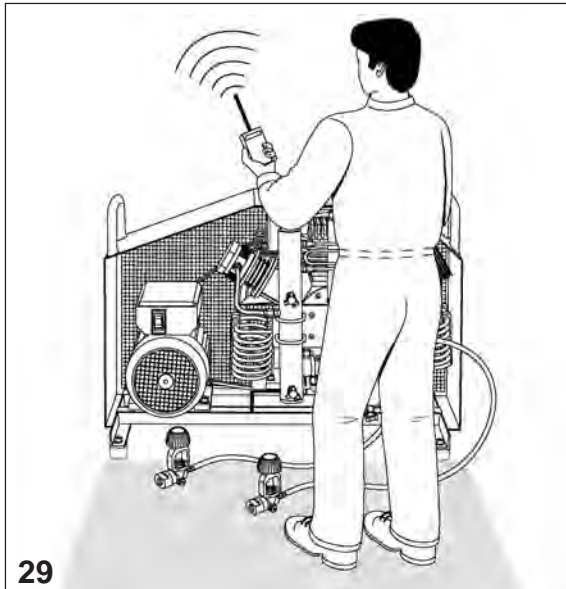

The reading of the machine noise level was taken from the “operator’s work place” (Fig. 29), with the following methods and results:

Table 3

METHODS OF MEASUREMENT ISO 3746	MCH 8/EM Standard	MCH 13-16/ET Standard	MCH 13-16/ETC Standard	MCH 13-16/SH Standard	MCH 13-16/DY Standard	MCH 13-16/DH Standard
Level of acoustic pressure at the operator’s work place	dB(A) 75,2	dB(A) 80,7	dB(A) 78,7	dB(A) 91,7	dB(A) 95,7	dB(A) 95,6
Level of acoustic power	dB(A) 88,0	dB(A) 93,2	dB(A) 91,2	dB(A) 106,2	dB(A) 109,2	dB(A) 109,1
Peak level	-	-	-	-	-	-
INSTRUMENTS						
Bruel & Kjaer sound level integrating meter	Mod. 2231 cl. 1					
Microphone for sound level meter	Mod. 4155 cl. 1					
Gauge	Mod. 4230 cl. 2					

Whenever the machines are used for work in environments where the daily noise level to which the operators are exposed is higher than 80 dBA, the employer must take steps to apply all the measurements necessary to safeguard the operator’s health. In particular, the operators must, if necessary, use all the individual protection devices to protect themselves from the noise level.



4

PRECAUTIONS FOR USE AND MAINTENANCE



Refer to the specific "Safety Regulation Manual" which is supplied enclosed with this manual (and which forms an integral part of the same).

4.1 Machine area diagrams 26

 4.1.1 Safety devices 27

 4.1.2 Residual risk areas 29

4.1 Machine area diagrams

The "Standard" series of compressors are machines that operate automatically and are run either electrically or by internal combustion.

Therefore the term "operator" as repeatedly defined in this manual refers to the following professional figures:

- **PERSON IN CHARGE OF MAINTENANCE**, this is the person entrusted with the handling, installation, start-up, regulation, cleaning, repair, changing of the tooling and maintenance of the machine. This person must be a qualified member of staff who has followed courses of specialization and who has had experience with the handling, installation, start-up and maintenance of machines and plants of a mechanical, electrical and pneumatic type. It is always advisable for the person in charge of maintenance to follow a training and specialization course on the machine given by the **AEROTECNICA COLTRI S.r.l.** technicians.
- **PERSON IN CHARGE OF OPERATION**, this is the person responsible for operating the machine whose work must be limited only to filling the cylinders and the control operations. This person must be perfectly acquainted with all the machine instructions and operating methods as described in this manual and the regulation manual.

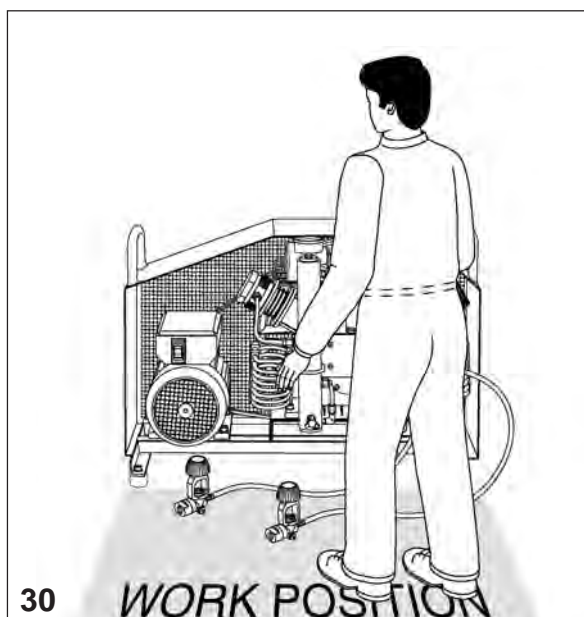

It is absolutely prohibited for the person in charge of operation to carry out any tasks other than those described above or to work in areas other than those marked in figure 30.



Safety devices

4.1.1

The “Standard” series of compressors for the various models (Fig. 31), are provided with a series of guards that are screwed into place and protection devices to ensure the safety of the operator that limit the operating field and guarantee a good machine performance.

The figure shows the safety devices provided on the compressors and the information labels applied.

“Standard” series of compressors

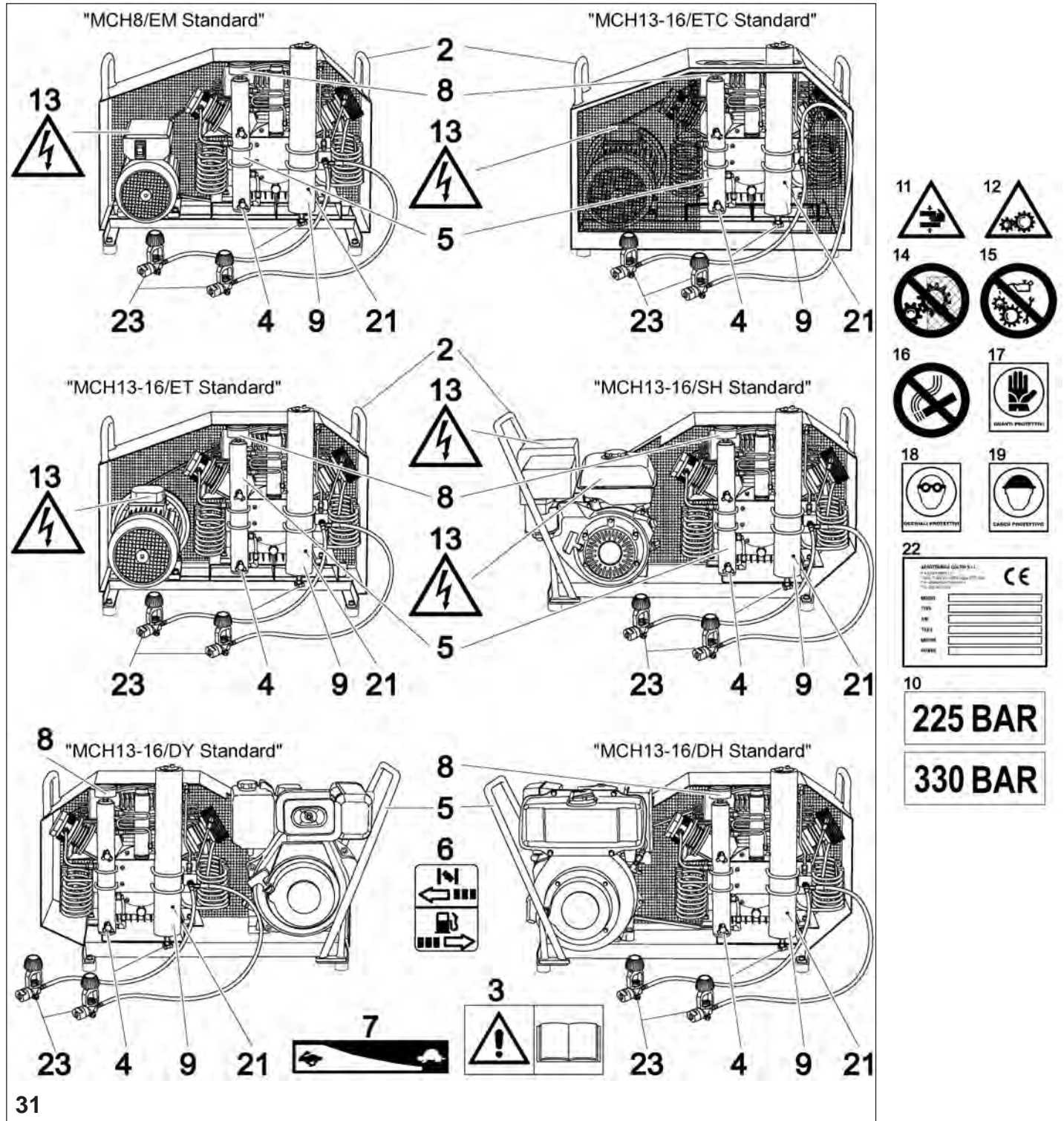



Table 1

POSITION	SAFETY DEVICE	DESCRIPTION	INSPECTION
1	Safety valves.	Protect the third stage and the cylinders from being overfilled; it is calibrated during the inspection of the compressors.	The safety valve must be checked at each refill; start up the compressor with the cylinder valves closed and the end valve open. Check that the safety valve starts operating correctly with the pressure gauge, open the valves and proceed with the refill.
2	Sound-proofed frame.	Built of steel.	Periodically check its integrity.
3	Symbol of caution and warning with a picture showing that the instruction manual must be read (only for internal combustion engines).		
4	Manual condensate discharge taps (automatic for all models except the Standard models).	The condensate is a milky-white emulsion formed of oil and water. The absorption of water by the filter causes wear on the filter itself and consequent contamination.	Open the discharge taps every 10-15 minutes and make sure the condensate comes out visibly and consistently. If the condensate is discharged automatically, check that it operates correctly by opening the manual discharge taps. The condensate should be present in minimum quantities.
5	Active carbon filter and molecular sieve.	The quality of the air depends to a great extent on the conditions of the filter and sieve.	The cartridge must be replaced before the air becomes foul smelling. For the frequency of replacement, see the instructions in Chapter 11, "Maintenance".
6	Symbol indicating the direction for the opening/closing of the air or the fuel (only for internal combustion engines).		
7	Symbol indicating the direction of the accelerator lever to increase/reduce the speed (only for internal combustion engines).		
8	Pressure gauge showing the operating pressure.		
9	Pressure switch that can be manually calibrated showing the maximum cylinder filling pressure; when the set pressure is reached, the compressor turns off.		
10	Maximum operating pressure.		
11	Symbol warning of the risk of crushing hands.		
12	Danger of moving parts symbol.		
13	Danger of voltage present symbol.		
14	Removal of safety devices prohibited symbol.		
15	Work on moving parts prohibited symbol.		
16	Smoking prohibited symbol.		
17	Gloves compulsory picture diagram.		
18	Goggles compulsory picture diagram.		
19	Helmet compulsory picture diagram.		
20	Rating plate on the electric motor giving data concerning voltage, phases, frequency, breaking capacity.		
21	Pump unit oil level indicator.		
22	Machine plate showing the CE mark.		
23	Hose area : danger of direct contact by the operator if breakage should occur during cylinder filling.		
(see "Safety Regulations" enclosed)	Warning to use the machine and carry out maintenance in accordance with the instruction manual.		
(see chapter 11)	Warning to cut off the power supply before carrying out any maintenance work.		



Residual risk areas

4.1.2

In some areas of the machine there are some residual risks that could not be eliminated during the design phase or protected by guards due to the particular operation of “**Standard**” series of compressors (Fig. 32÷34). Each operator must be aware of the residual risks present on the machine in order to avoid possible accidents.

MCH 13-16 STANDARD

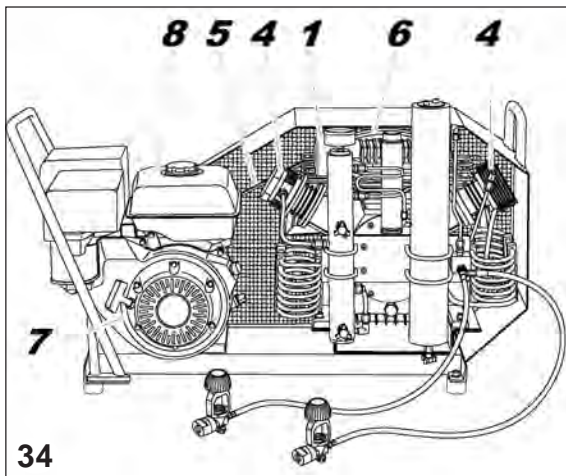
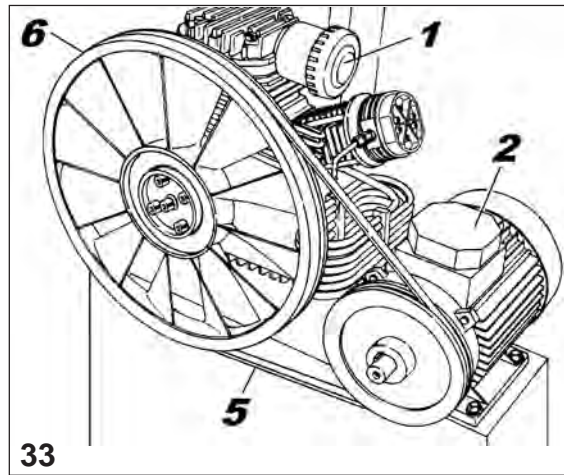
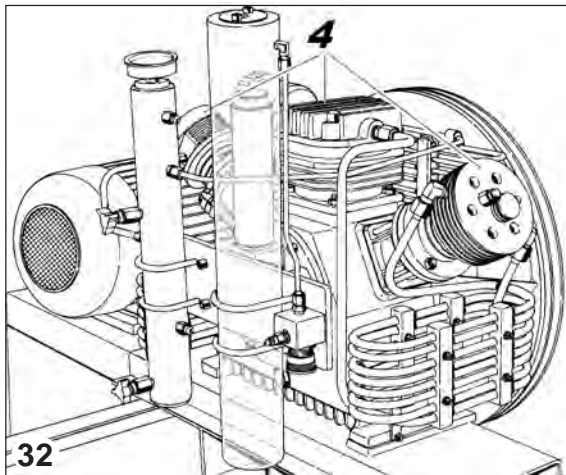

Table 2

POSITION	DESCRIPTION
1	Danger of polluting the air produced owing to the possibility of mixing fumes or vapours from the lubricating oil with the compressed air produced.
2	Electrical danger. Use the machine with suitable protection from the electrical power supply especially in the presence of water and humidity.
3	Danger deriving from the noise emitted by the compressor if maintenance work is carried out without the safety guards.
4	Pump unit area : danger from heat. For any maintenance operation (requiring the removal of the safety guard) wait about 30 minutes after turning off the engine.
5	Transmission belt area: danger of crushing or dragging by the belts when maintenance work is carried out without the safety guards.
6	Cooling fan area: danger of impact and abrasion if the cylinders are refilled without the safety guards.
7	Engine area: dangers from heat; when the engine has stopped wait for it to cool down before touching the parts with the hands.
8	Tank area: danger of explosion, fire.



5

UNPACKING AND HANDLING THE MACHINE



This chapter provides the instructions necessary for unpacking and handling the machine.

5.1	Unpacking the machine	30
5.2	Pack contents	30
5.3	Handling the machine	31

5.1 Unpacking the machine

The machines in the “Standard” series are delivered fully assembled, but with the hoses supplied separately.

The compressors are packed in cardboard boxes fitted on europallets to make handling and transportation easier.

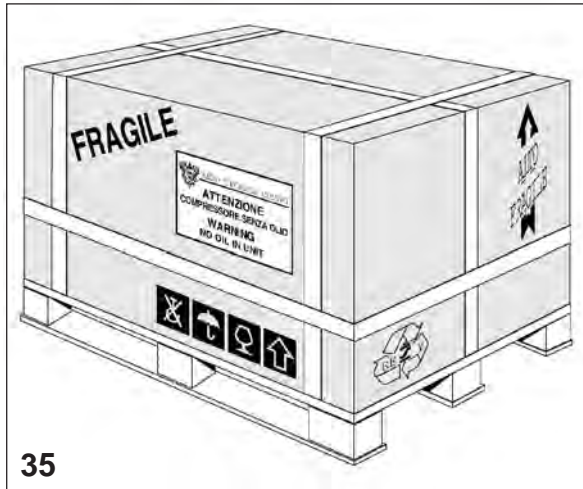

To unpack the boxes containing the machine, follow the instructions given on the outside of the boxes with great care (Fig. 35).

5.2 Pack contents

The standard equipment with which the machine is supplied is:

- 2 refill hoses measuring 1200 mm with valve;
- operating and maintenance booklet;
- enclosure with the Instruction Manual (Safety regulations);
- lubricating oil in cans (2 lt);
- engine operating and maintenance booklet (only for the internal combustion models).

Handling the machine

5.3

Having removed the compressor from its pack as described in the previous paragraph, the machine can be moved to its place of installation.

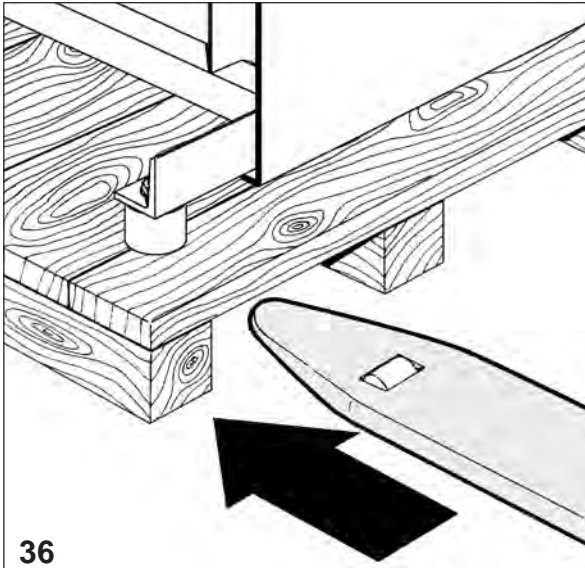

To carry out this operation, it is necessary to use a fork-lift truck or transpallet (of a suitable capacity), the forks of which must be positioned between the feet of the europallet on which the machine is placed (Fig. 36).

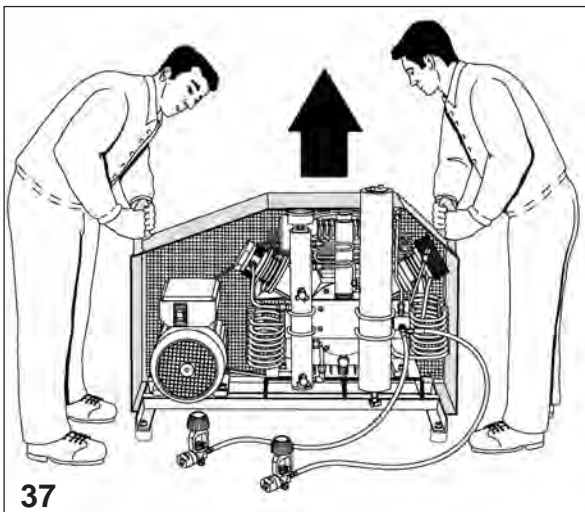

When the compressors in the “**Standard**” series are not fitted on europallets, they can easily be moved even by hand thanks to the handles provided for this purpose on the frame (Fig. 37-38).

CAUTION

In this second case, the lifting operation must be carried out by at least 2 people at the same time.

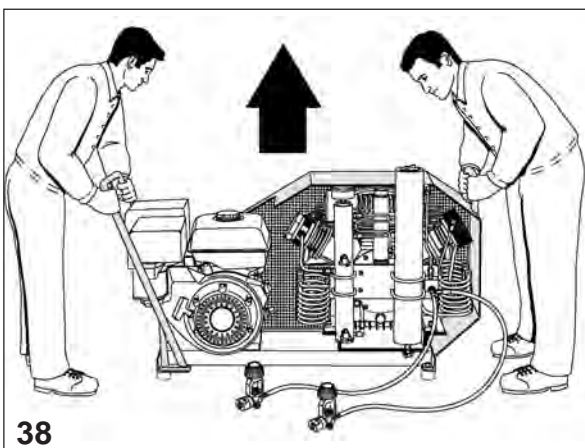



6

INSTALLATION



This chapter provides a description of the operations for installing the machine.

The following instructions presume that the operator has already become familiar with the regulations given in Chapter 4, "Precautions for use and maintenance".

- 6.1 Positioning 32
- 6.2 Connections 33
 - 6.2.1 Connecting the air intake extension 33
 - 6.2.2 Connecting the refill hoses 35
 - 6.2.3 Electrical connection for models MCH 8/EM - MCH 13-16/ETC - MCH 13-16/ET ... 36

WARNING



Before proceeding with the installation operations described below, read Chapter 4, "Precautions for use and maintenance" carefully and proceed as directed.

6.1

Positioning

- 1 Position the machine in the chosen area and check that it is on a level (the plane should not be at an angle of more than 5° to assure perfect lubrication). For the machine sizes, see paragraph 3.1.2 "Sizes and weights".

WARNING

The compressors used on board boats can be certified with inspections by R.I.Na (Italian Register of Shipping), to be requested as a special supply.

- 2 Check that in the place chosen for installation there are suitable ventilation conditions:
 - a good change of air (several windows), no dust and no risks of explosion, corrosion or fire.
- 3 Use in environments with a temperature of over 40 °C makes it necessary to use synthetic lubricating oil and air-conditioning must be provided for the environment.

CAUTION



The "Standard" series of compressors with internal combustion engine, must be installed in the open air.

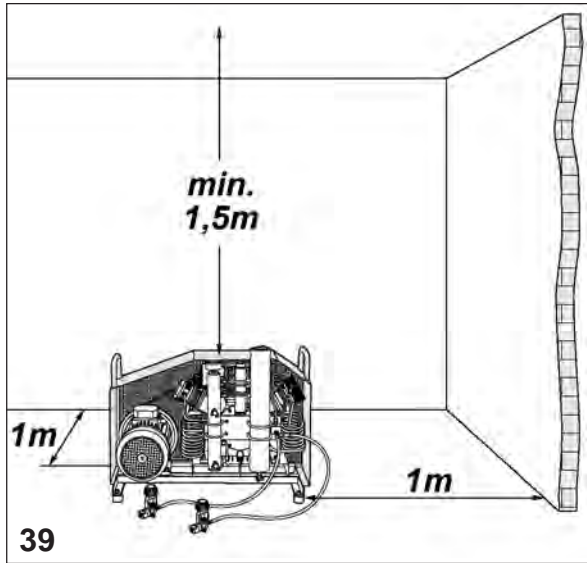

- 4 Position the machine at a minimum distance of 1 m. from the surrounding walls and at a distance of not less than 1.5 m. from the ceiling in order not to compromise the proper operation and cooling of the pump unit (Fig. 39).

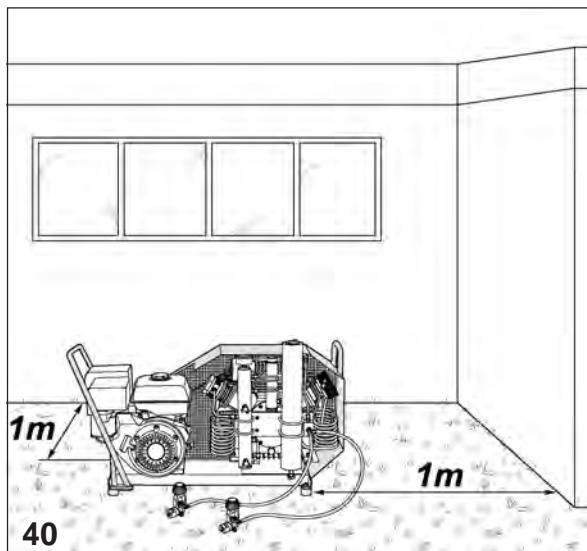

- 5 The models with the internal combustion engine must be placed outside at a minimum distance of 1 m from buildings and machines (Fig. 40).

- 6 Make sure that the machine is in a well-lit area, so that each detail can be clearly made out (especially the writing on the plates).

Add artificial lighting to the area if the natural lighting is not sufficient for the requirements mentioned

Connections

6.2

Connecting the extension for the air intake

6.2.1

For models run on electricity, if the machine should be placed in a location without the ventilation characteristics described in the previous paragraph, an extension must be installed to have an intake of air from outside or from a place with the ventilation characteristics described.

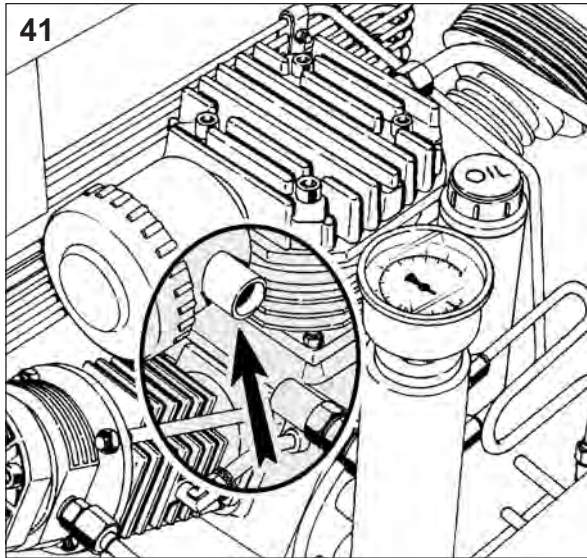

This extension which is supplied as an optional, must be connected to the appropriate intake attachment (Fig. 41).

WARNING



Only use a flexible pipe provided with a steel spiral internal reinforcement to prevent bending and a consequent reduction in the cross section.

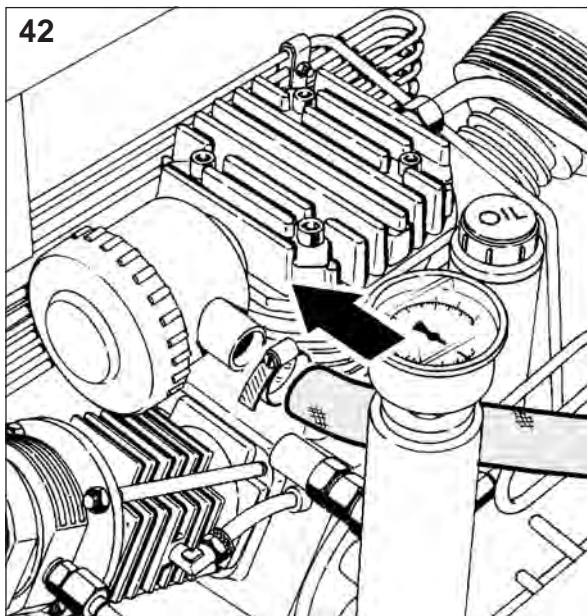

1 Connect the extension pipe to the connector (Fig. 42).

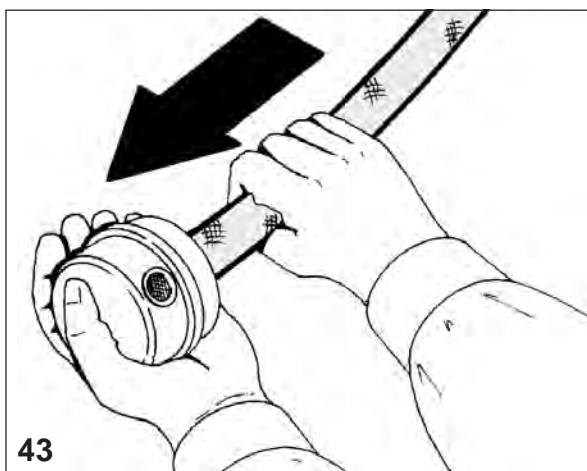

2 Fit the additional intake filter on the end of the extension pipe (Fig. 43).



- 3 Position the end of the extension on which the intake filter is fitted (air intake) in a ventilated place protected from atmospheric agents.

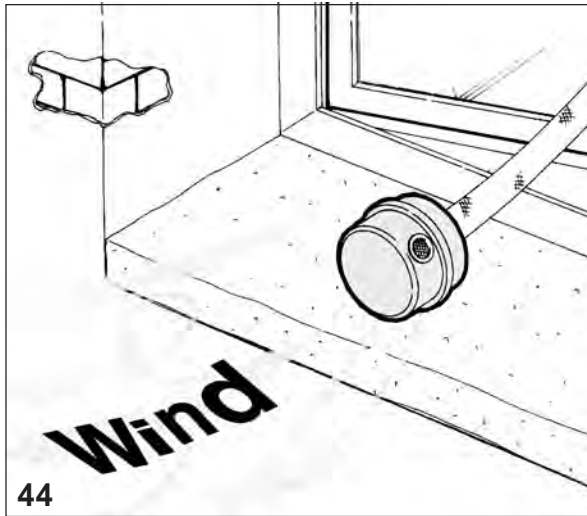

- 4 Direct the air intake in a position "against the wind" (Fig. 44).

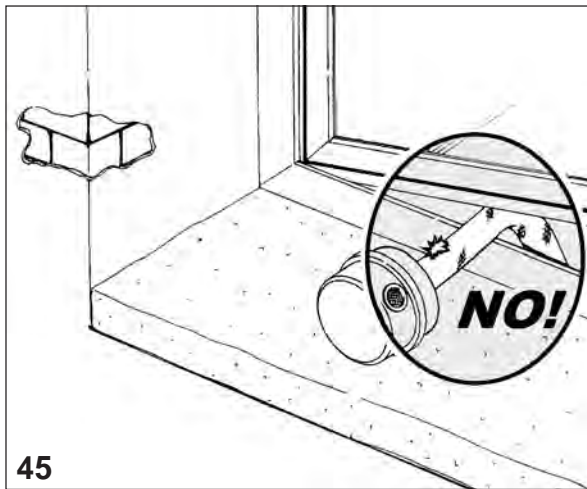

- 5 Make sure that there are no bends or breakages along the length of the pipe (Fig. 45).

If the extension should have broken during the connection to the head, it must be replaced.

WARNING

Make sure that the air intake is away from exhaust fumes given off by internal-combustion engines or harmful fumes.



Connecting the refill hoses

6.2.2

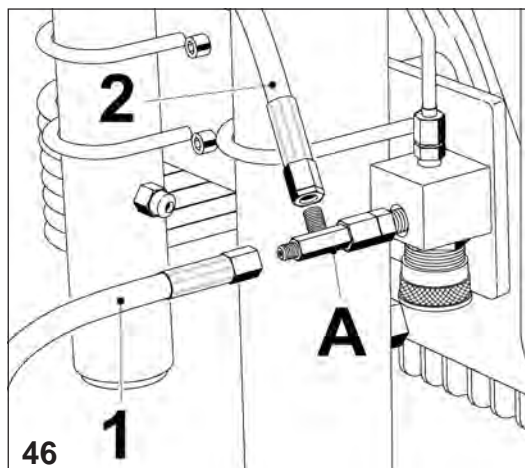

- 1 Screw hose N° 1 into the special attachment "A" (Fig. 46) without securing it too tightly (see point 2).



- 2 Connect hose N°2 in the same way as described in the previous point.
- 3 A torque wrench should be available to fasten the hoses.

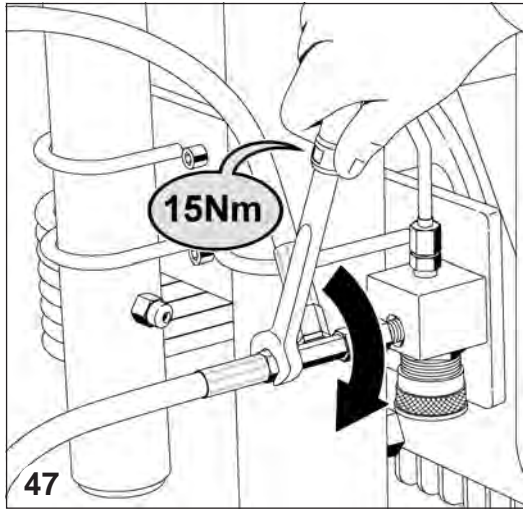

- 4 Tighten the hoses to the machine with a torque wrench setting of 15Nm (Fig. 47).

NOTE:

- the hoses should be replaced every so often (every year or every 1000 hours) or when they show signs of being scratched. For this purpose, check the number of operating hours of the hoses that are to be disconnected (on the hour counter).
- The minimum radius of curvature of each hose must not be less than 250 mm.

6.2.3

**Electrical connection for models MCH 8/EM - MCH 13-16/ETC
MCH 13-16/ET**

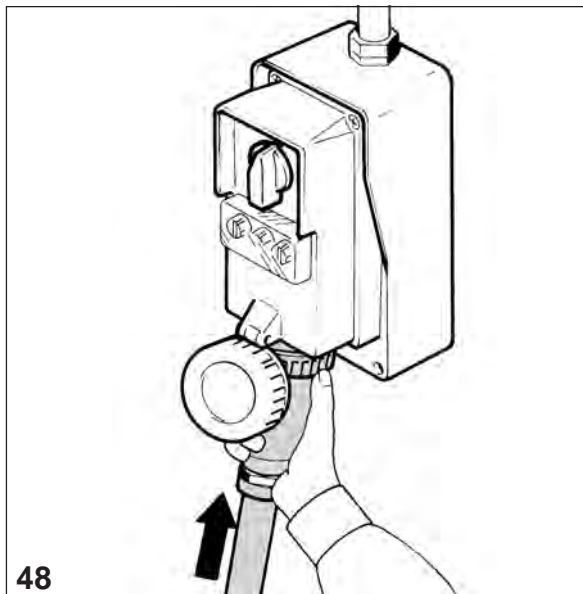

The compressor is supplied with an electric cable (Fig. 48).

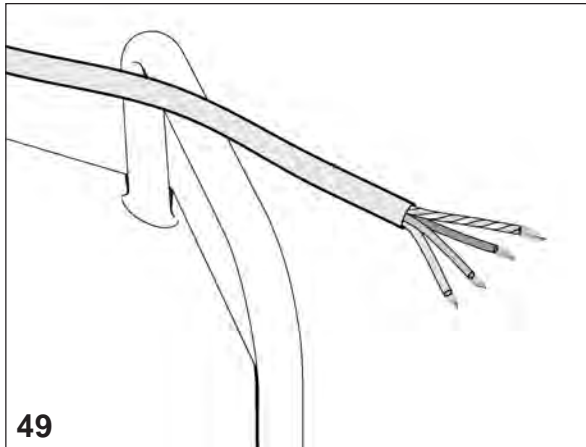

- 1 Fit an industrial plug to the machine supply cable (6-pole 16A) (Fig. 49).

WARNING

Before fitting the plug into the mains supply, check that the installation has been set up in accordance with the regulations in force in the country where the compressor has been installed.



- 2 Also check that the details on the machine rating plate are compatible with the mains power supply, especially the nominal current and input voltage.
- 3 The mains power supply should be provided with an effective grounding system. It is particularly important to check that the earth resistance value complies with the protection and operating requirements of the electrical installation of the compressor.

WARNING

An effective machine earthing system is of fundamental importance for safety purposes.





7

CONTROL PANEL



This chapter provides a description of the functions carried out by the various devices fitted on the control panel.

7.1	Control panel.....	38
7.1.1	Wall-mounted control panel for models with electric power supply (optional)	39
7.1.2	Controls on board the internal combustion engines	40
7.2	Indication and control devices	41

7.1 Control panel

The “Standard” series of refill stations are not provided with an actual control panel as such.

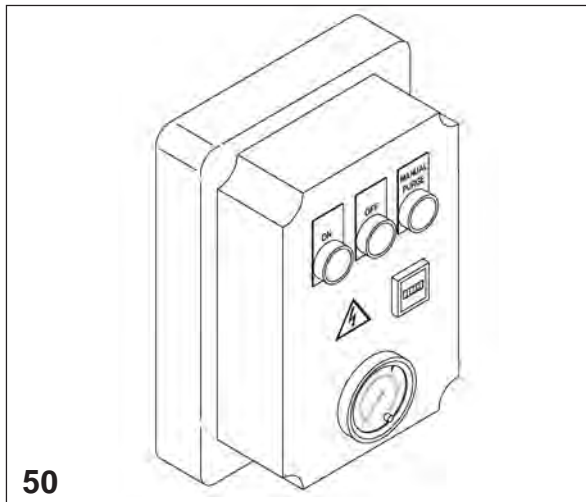

A control board housing the machine pushbuttons and control instruments is available on request (optional) for the models with **electric power supply** (Fig. 50) that can also be made by the purchaser, following the laws in force concerning such matters.



NOTE

This type of control panel has not been designed to be fitted on board the machine.

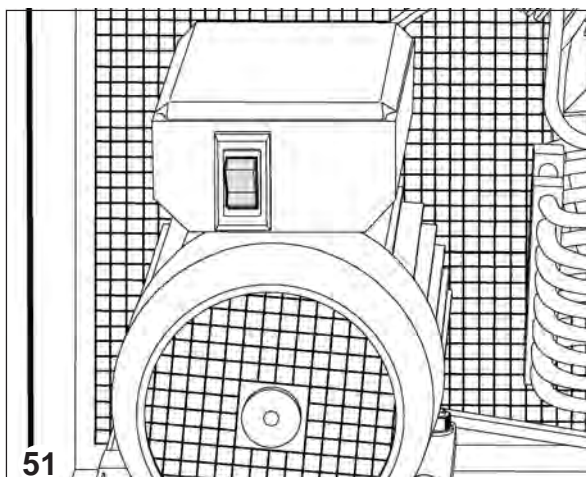

The model “MCH 8/EM Standard” (electric single phase) is provided with an “ON/OFF” start switch fitted directly on the engine (Fig. 51).

For models with an **internal combustion engine**, the start controls are only those provided on board the engine supplied.

Wall-mounted control panel for models with electric power supply (optional)
7.1.1

As previously mentioned, a control board can be supplied that houses 3 operation pushbuttons and the counter that memorizes the number of operating hours (Fig. 52).

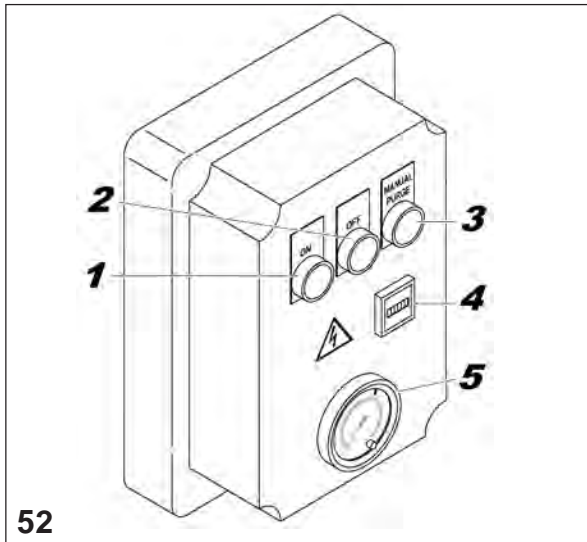
1 ON - green button.

It enables the compressor to be started up.
The button has a light inside that comes on when it is pressed.

(The general switch must be in the "ON" position).

2 OFF - red button.

It enables the compressor to be stopped.
The button has a light inside that comes on when the power supply is connected.

3 MANUAL PURGE - yellow button.

It enables the condensate to be purged manually.

This function permits the pressure present inside the condensate separators and the filter to be discharged, evacuating the condensate through the electromagnetically- controlled valves.

This operation is normally carried out by the timer at regular intervals.

4 HOUR COUNTER

It enables the actual operating hours to be memorized in order to be able to carry out the maintenance work as provided for.

5 PRESSURE SWITCH

It indicates the maximum cylinder filling pressure and can be adjusted manually. If the set pressure is reached, the compressor is switched off.



7.1.2 Controls on board the internal combustion engines

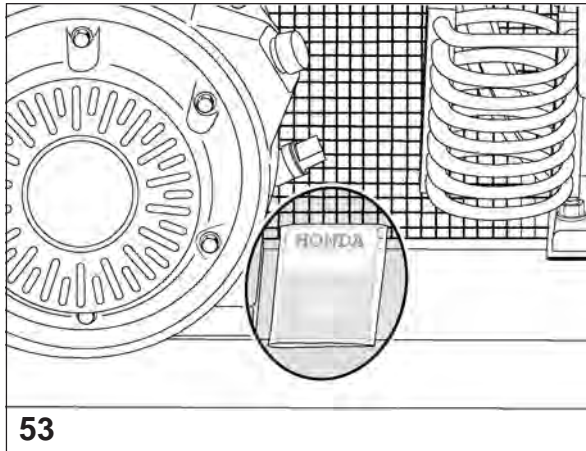

Each refill station run by petrol or diesel fuel is provided with an operating and maintenance manual for the engine fitted (Fig. 53) which is compiled by the engine manufacturer.

These enclosures give all the information concerning the engine and its operation.
Below is a brief description of the main controls on board the engine (Fig. 54).

PETROL ENGINES (Fig. 54)

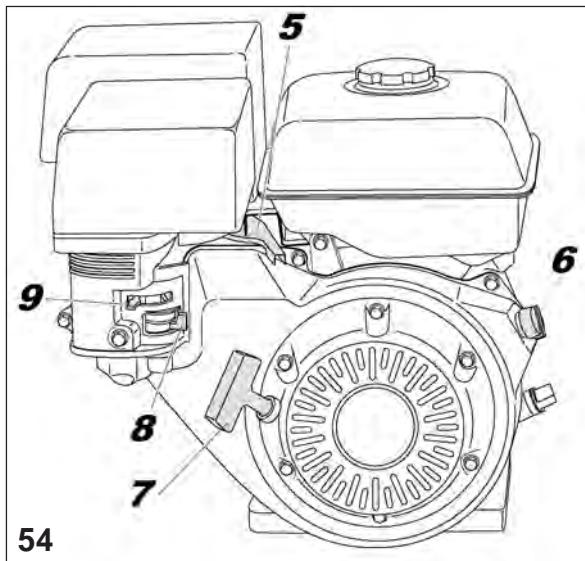

- 5 Accelerator control lever.
- 6 Engine "ON/OFF" switch.
- 7 Start handle.
- 8 Fuel lever.
- 9 Air lever.



DIESEL ENGINES (Fig. 55)

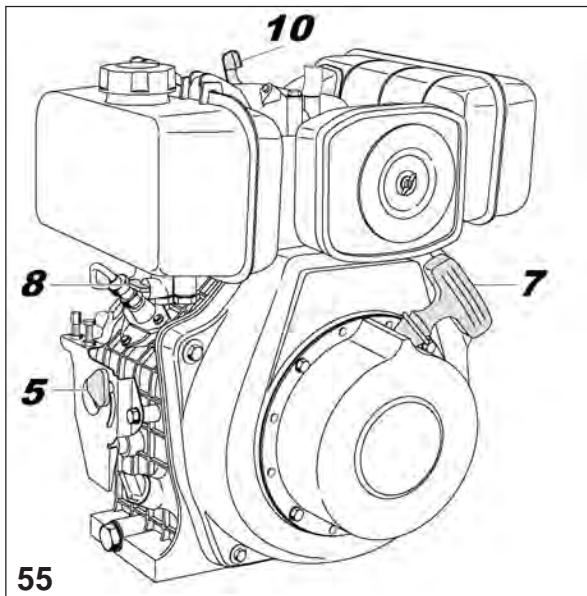

- 5 Accelerator control lever.
- 7 Start handle.
- 8 Fuel lever.
- 10 Decompression lever.

The pictures are given only as an indication.

Indication and control devices

7.2

The “**Standard**” series of refill stations are fitted with some devices to control the discharge of condensation, the cleaner filter and the lubrication oil level (Fig. 56).

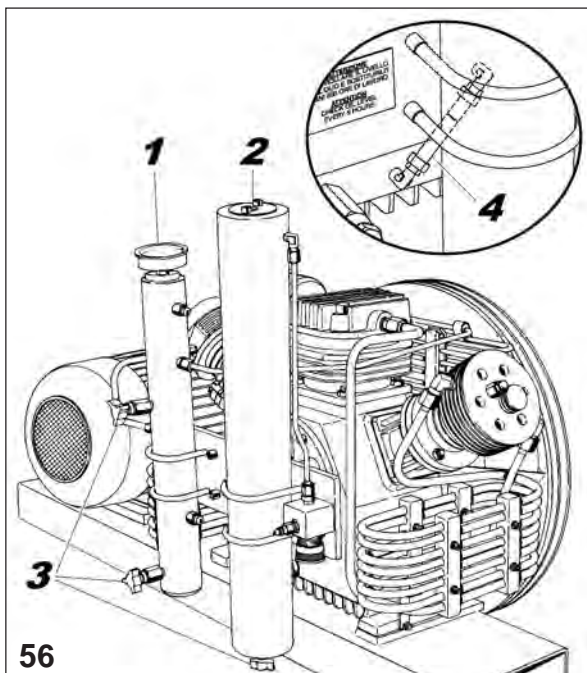

- 1 Pressure gauge**
It indicates the working pressure.
- 2 Strainer filter**
The purpose of this device is to withhold the impurities present in the air before they enter the cylinders.
- 3 Condensate discharge taps**
They enable the condensate that has accumulated during machine operation to be discharged by hand.
The condensate is discharged automatically by the machine by means of electromagnetically-controlled valves.
- 4 Lubricating oil level indicator**



8

START AND STOP



This chapter describes the operations regarding the machine start up phase.

The following instructions presume that the operator has already become familiar with the precautions given in Chapter 4 "Precautions for use and maintenance" and that the machine has been installed according to the instructions given in the previous chapter.

8.1	Filling the machine	42
8.2	Checks	44
8.2.1	Models with electric power supply	44
8.2.2	Models with petrol supply	46
8.2.3	Models with diesel fuel supply	50
8.2.4	Stopping the internal combustion engine	55

8.1 Filling the machine

WARNING

Before proceeding with the start up operations described below, read chapter 4, "Precautions for use and maintenance" very carefully and follow the advice given.

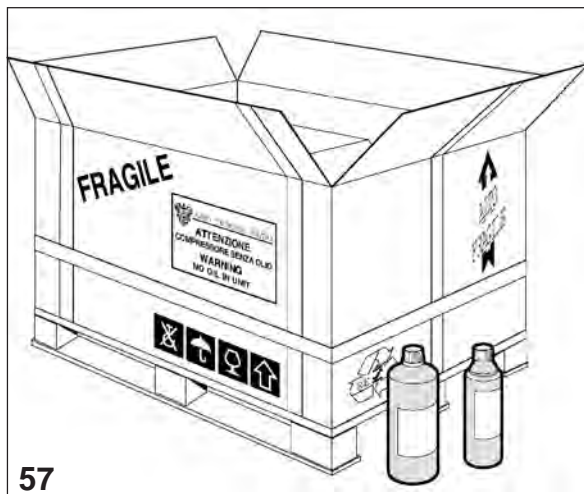

Fill the lubricating oil sump of the pump unit when the machine is switched off.

The machine is delivered without lubricating oil which is collected in the cans that can be found inside the machine packaging (Fig. 57).

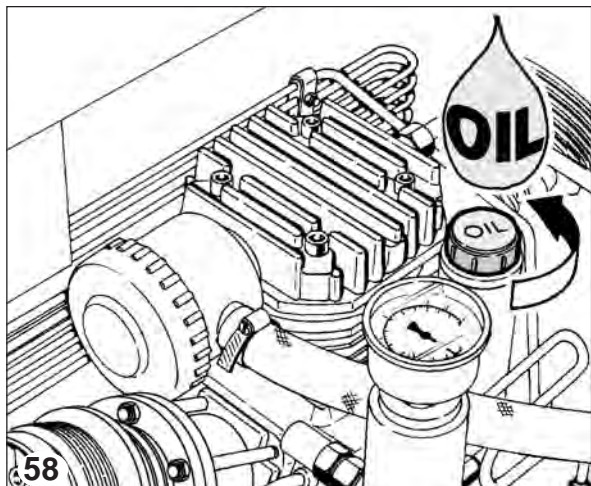

The oil is added by removing the cap marked with the word "OIL" (Fig. 58).

The quantity of oil to be poured in is 1.5 lt. and the level should be checked with the machine turned off, bearing in mind that an excess amount of oil may cause infiltrations in the cylinders and a deposit on the valves. On the contrary, if the oil level is too low, the tang of the connecting rod is prevented from providing the correct lubrication with the possibility of causing a seizure of the cylinders.

To check the amount of oil added, see the next paragraph.

When the operation has been completed, screw the cap up again.

MODELS WITH INTERNAL COMBUSTION ENGINES

For models run by internal combustion engines, **the level of the engine oil** must be checked.

NOTE

If the engine is run with an insufficient level of oil, it may be irreparably damaged.

Check the oil level on a flat surface with the engine off.

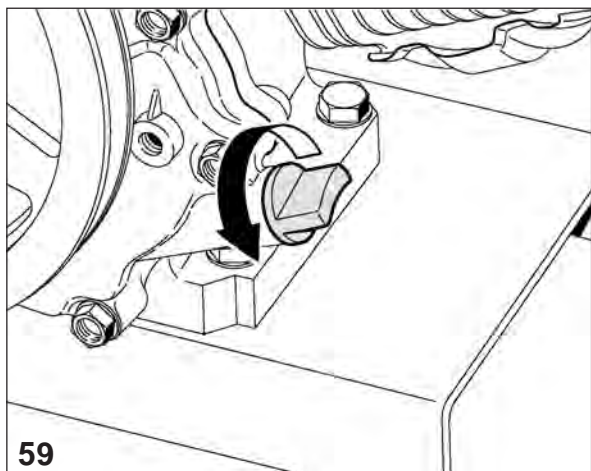

Remove the oil cap and clean the dipstick (Fig. 59).

Insert the dipstick in the oil refill hole without screwing it down.

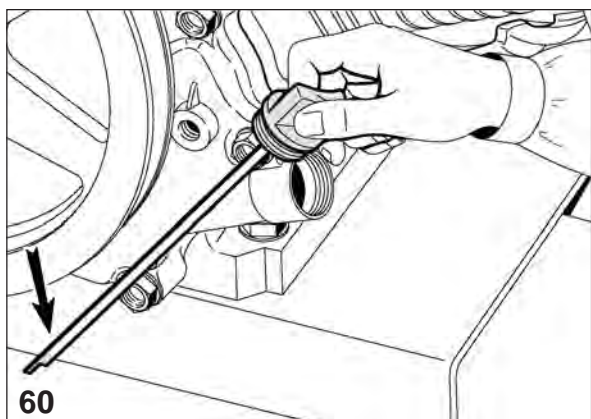

Remove the dipstick and check the level (Fig. 60).



If the oil level is low, top it up until the maximum level is shown on the dipstick. Do not exceed this level. Use oil of the recommended type.

CAUTION

The life of the engine may be reduced if non-detergent oil or oil for a two-stroke engine is used.

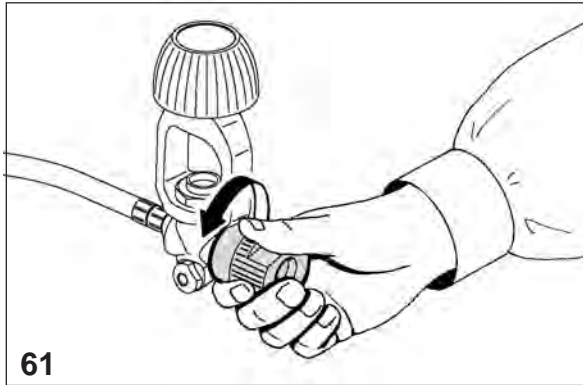
8.2 Checks**8.2.1 Models with electric power supply****61**

- 1 Turn on the manual condensate discharge taps (Fig. 61).

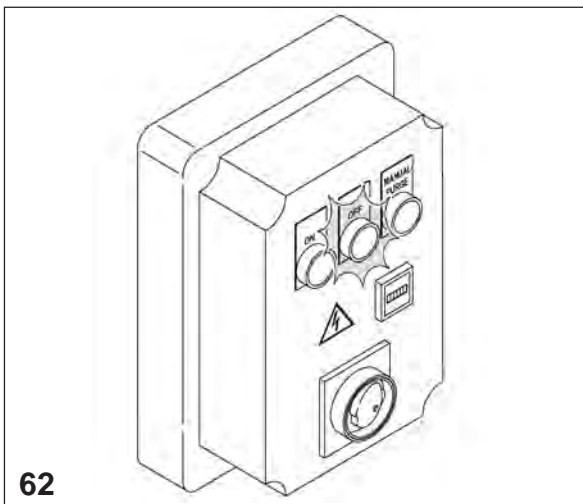
**62**

- 2 Turn the machine on by moving the general switch to the "ON" position. If the model has a control board (optional) check the machine has been switched on by means of the red "OFF" button light (Fig. 62).
- 3 Run the compressor for about 10 minutes then leave it at a standstill for 20 minutes.

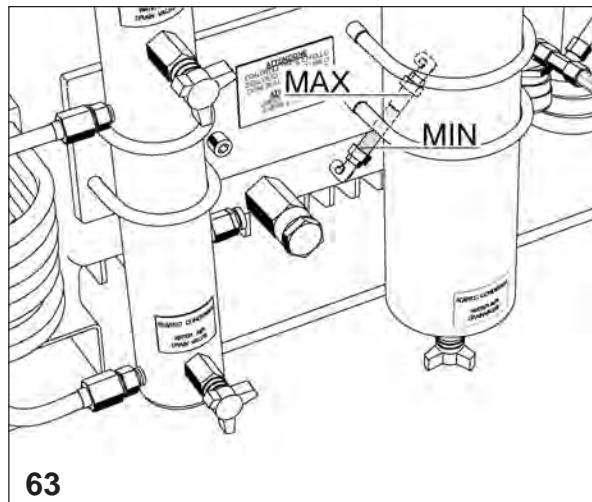

4 Check the level of the pump unit lubricating oil by looking at the indicator provided (Fig. 63).

If the level is too low, top the oil up following the instructions given in the previous paragraph.

If the level is too high, discharge some of the oil as described in chapter 11.4 "Changing the lubricating oil".

To dispose of the oil, refer to chapter 10.2, "Disposal of waste".

5 The operation to check the level of the lubricant must be carried out when the machine arrives and then before starting up the compressor. It must be remembered that if the level is too low or too high it may compromise the running of the compressor.

6 In order to check the correct connection of the electrical phases, the engine should be turned on and the direction of rotation checked.

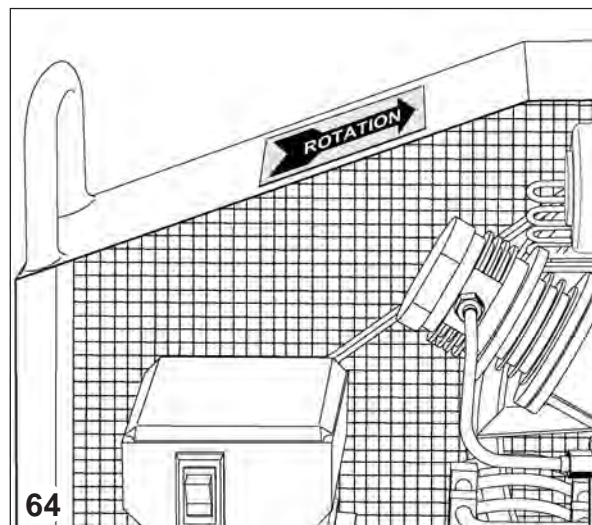

If the direction of rotation does not correspond with that shown by the arrow located on the panel (or on the engine Fig. 64-65), the electricity supply must be cut off and two of the 3 phases must be inverted on the main input or on the plug (Fig. 66).

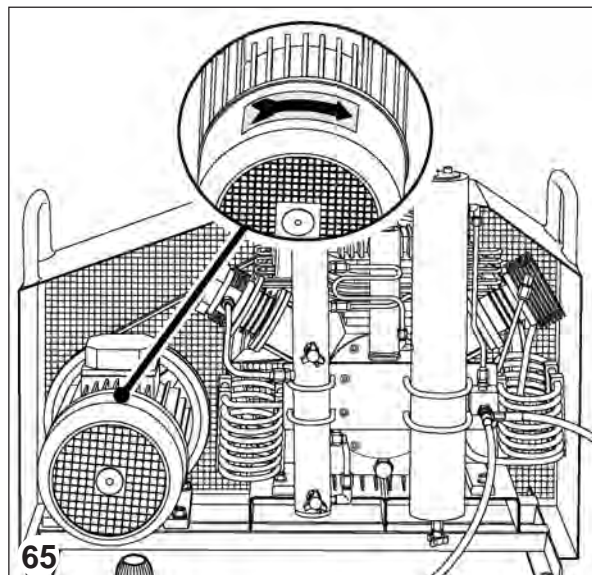

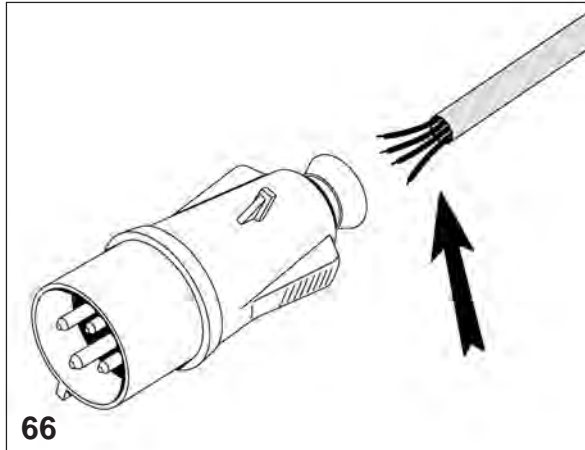

CAUTION

The yellow/green wire corresponds to the earthing. **DO NOT** disconnect or invert this wire.

8.2.2 Models with petrol supply

AIR FILTER

CAUTION



Never run the engine without the air filter. The engine would certainly be damaged.

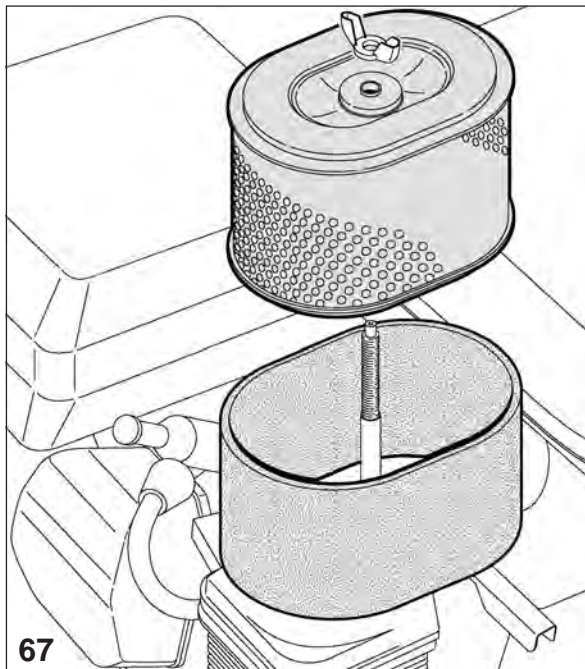

Clean the filtering elements (Fig. 67) of the air filter until they are quite clean and check that they are in good operating condition (see the instructions in chapter 11 entitled "Maintenance" in this manual).

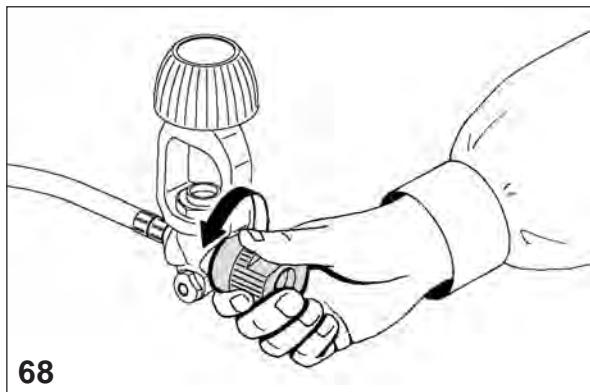

Having carried out the previously mentioned checks on the engine, open the cylinder refill cock (Fig. 68).

Start the compressor up following the instructions given below.



1 Add fuel to the tank (unleaded petrol or diesel according to the type of engine fitted) (Fig. 69).

WARNING

- The fuels are highly inflammable and may explode.
- Supply the engine with fuel in a well-ventilated place when still. Do not smoke and do not allow naked flames or sparks to get near the engine during refilling or in the area where the petrol is kept.
- Do not fill the fuel tank right up. There must not be any fuel in the filling neck. After filling, check that the tank has been closed properly.
- Take care not to spill any fuel during filling, otherwise it could catch fire. If petrol is spilt, wipe it all up before turning the engine on.
- Avoid repeated or prolonged contact of petrol with the skin and do not breathe in the vapours. **KEEP OUT OF CHILDREN'S REACH.**

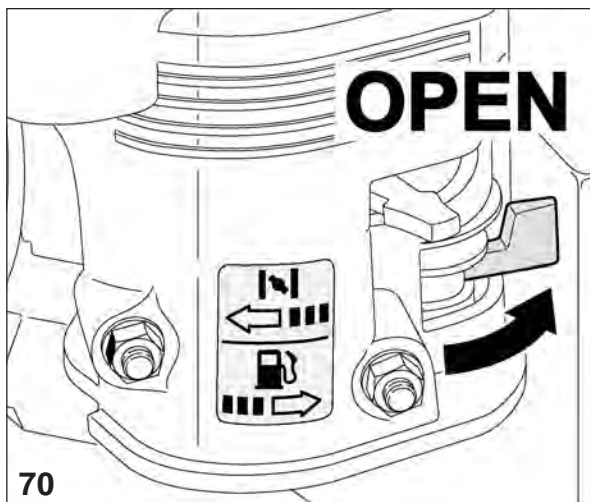

Move the fuel lever to the "open" position (anti-clockwise direction) (Fig. 70).

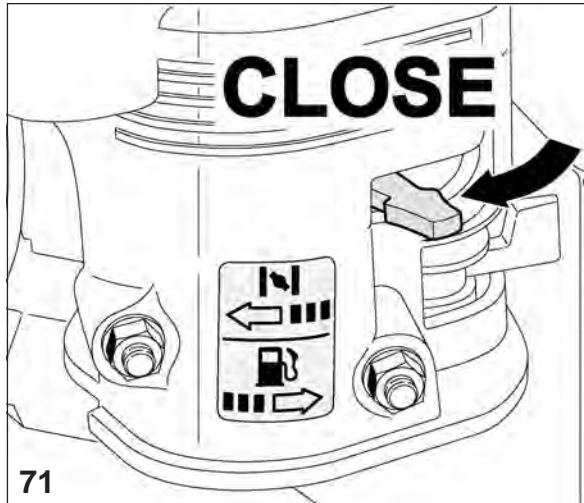

Move the air lever to the “closed” position (clockwise direction) (Fig. 71).

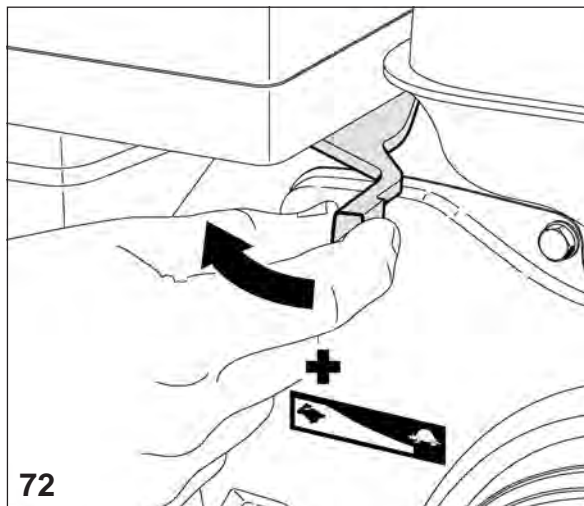

Turn the accelerator lever slightly in an anti-clockwise direction (Fig. 72).

ENGINE WITH PULL START

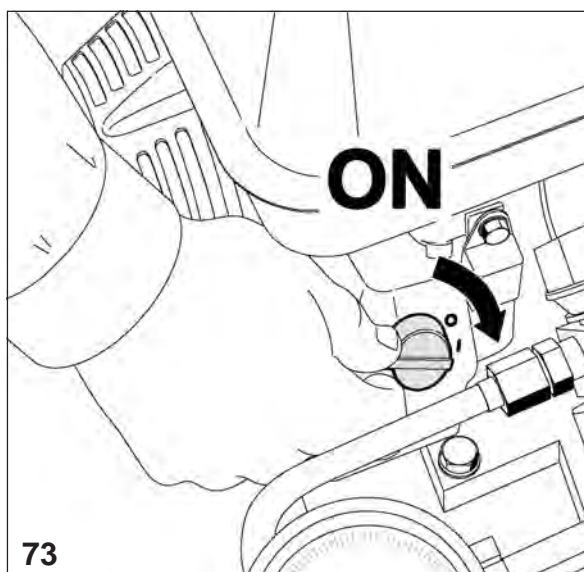

Turn the engine starter switch to the “ON” position (Fig. 73).

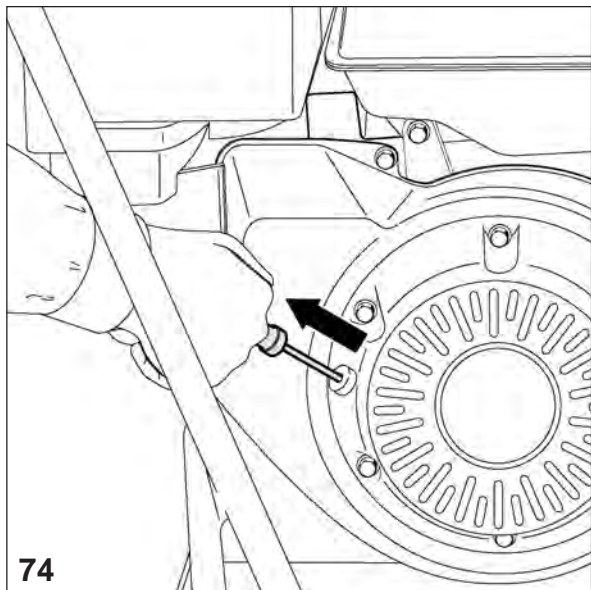

Pull the starter cord until a certain resistance is felt, then pull hard (Fig. 74).

NOTE

Do not allow the cord handle to return quickly and bang against the engine. Return it slowly into position to avoid damaging the starter system.



ENGINE WITH ELECTRIC START

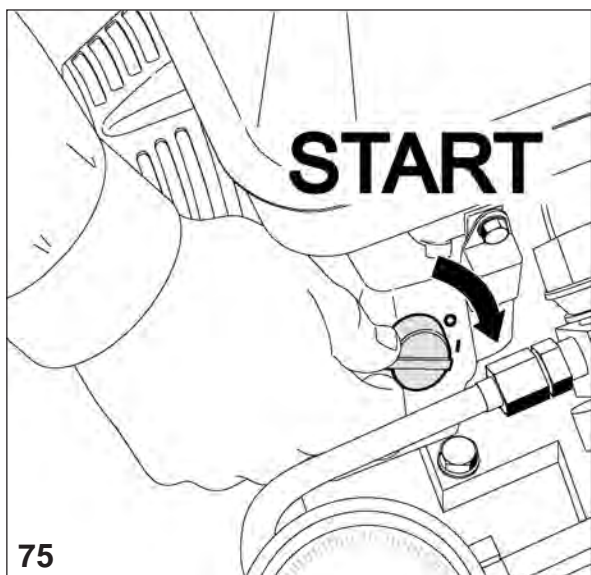

Move the engine starter switch to the "START" position and keep it in this position until the engine starts up (Fig. 75).

NOTE

Do not use the starter motor for more than 5 seconds at a time. If the engine does not start up, let go of the key and wait 10 seconds before using the starter motor again.



When the engine starts up, move the switch back to the "ON" position.

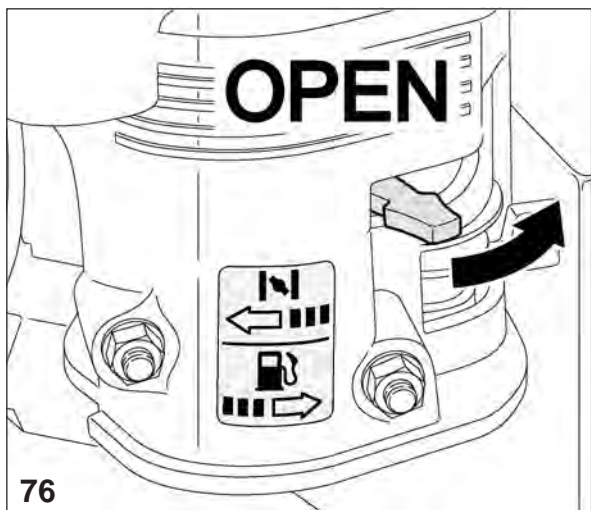

As the engine warms up, gradually move the air lever to the "OPEN" position (Fig. 76).

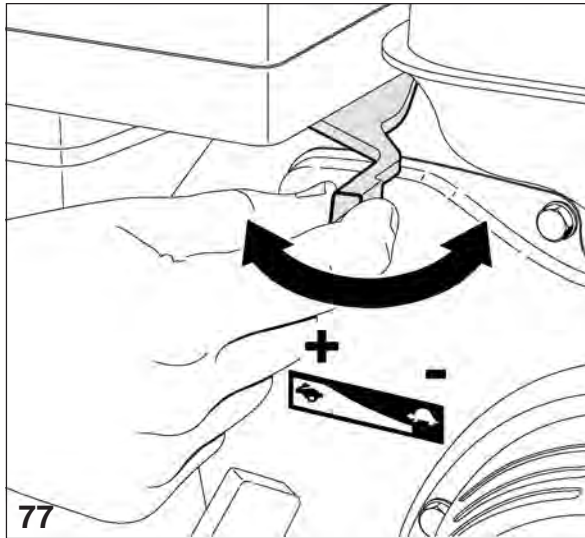

Move the accelerator control lever into position to obtain the required number of revs (Fig. 77).

Run the compressor for about 10 minutes then leave it at a standstill for 20 minutes.

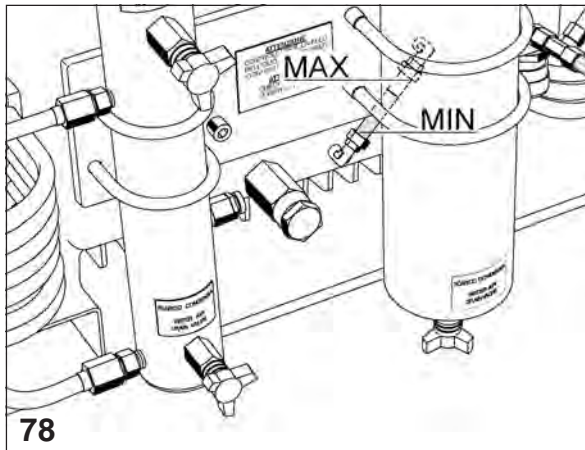

Check the level of the lubricating oil of the pump unit by looking at the indicator (Fig. 78).

If the level is too low, top the oil up following the instructions given in the previous paragraph.

If the level is too high, discharge some of the oil as described in chapter 11.4 "Changing the lubricating oil".

To dispose of the oil, refer to chapter 10.2, "Disposal of waste".

The operation to check the level of the lubricant must be carried out when the machine arrives and then before starting up the compressor. It must be remembered that if the level is too low or too high it may compromise the running of the compressor.

8.2.3 Models with diesel fuel supply

AIR FILTER

CAUTION



Never run the engine without the air filter. The engine would certainly be damaged.

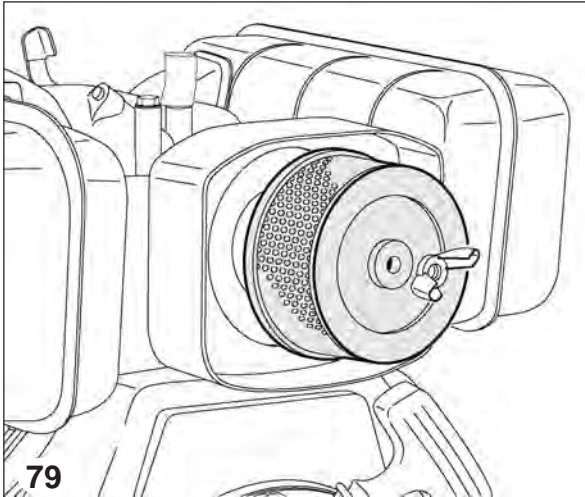

Clean the filtering elements (Fig. 79) of the air filter until they are quite clean and check that they are in good operating condition (see the instructions in chapter 11 entitled "Maintenance" in this manual).

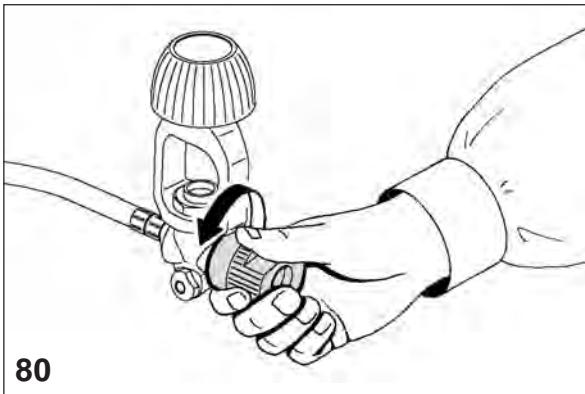

Having carried out the previously mentioned checks on the engine, open the cylinder refill cock (Fig. 80).

Start the compressor up following the instructions given below.

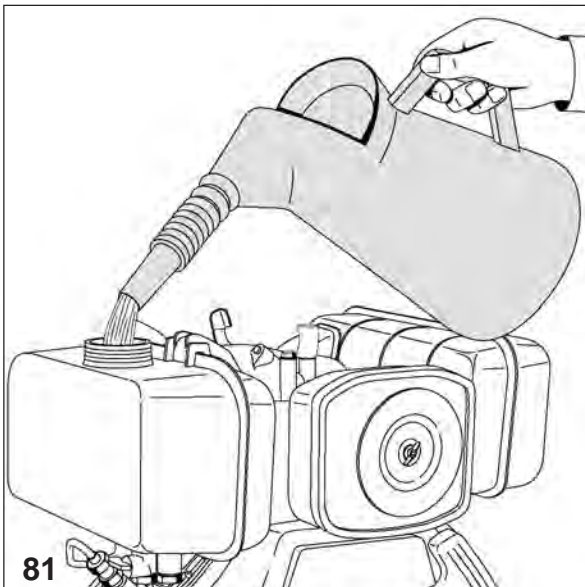

Add diesel fuel to the tank (Fig. 81).



WARNING

- The fuels are highly inflammable and may explode.
- Supply the engine with fuel in a well-ventilated place when still. Do not smoke and do not allow naked flames or sparks to get near the engine during refilling or in the area where the petrol is kept.
- Do not fill the fuel tank right up. There must not be any fuel in the filling neck. After filling, check that the tank has been closed properly.
- Take care not to spill any fuel during filling, otherwise it could catch fire. If any diesel is spilt, wipe it all up before turning the engine on.
- Avoid repeated or prolonged contact of petrol with the skin and do not breathe in the vapours.
KEEP OUT OF CHILDREN'S REACH.

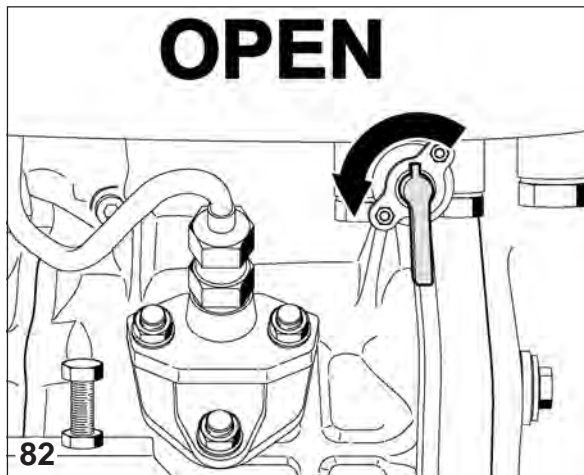

Move the fuel lever to the "open" position (anti-clockwise direction) (Fig. 82).

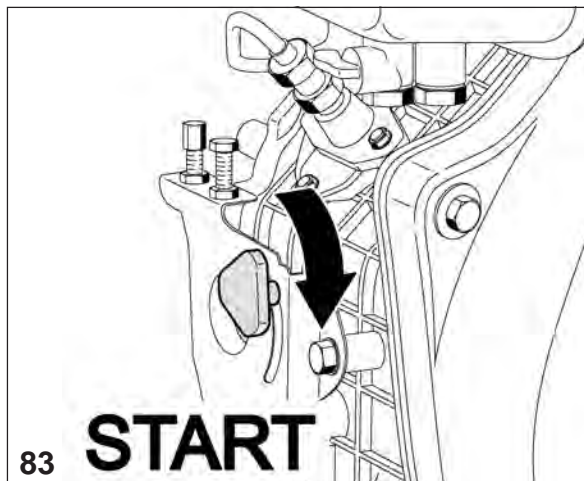

Turn the accelerator lever to the "START" position (Fig. 83).

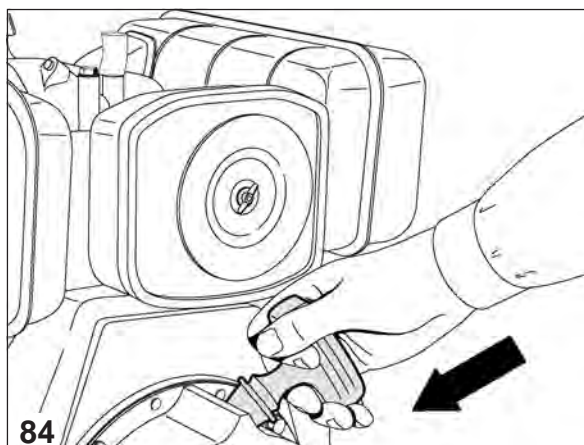

Pull the starter cord until a certain resistance is felt. Let go of the cord slowly (Fig. 84).

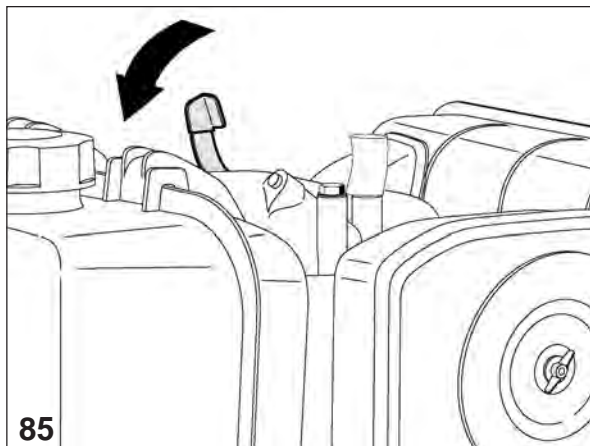

Push the decompression lever downwards (Fig. 85). It will return automatically with the extraction of the self-winding device.

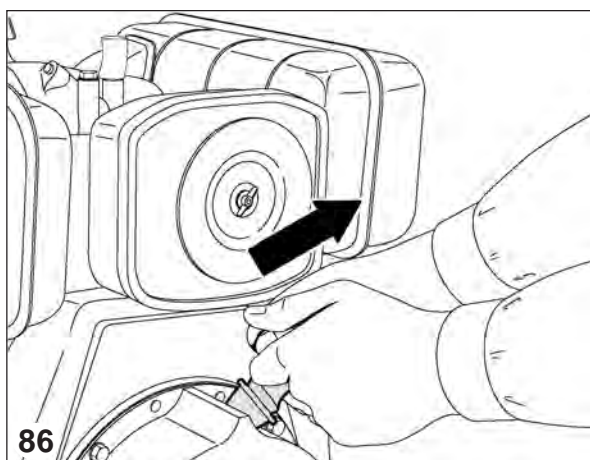

Pull the knob of the self-winding device firmly and quickly with both hands (Fig. 86).

CAUTION

Do not allow the cord handle to return quickly and bang against the engine. Return it slowly into position to avoid damaging the starter system.

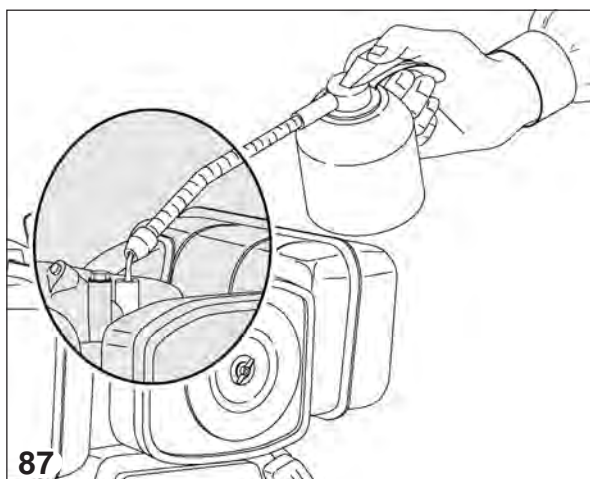

WARNING

At low temperatures when it is difficult to start the engine, remove the rubber cap on the equalizer cover before start up and add 2 cu. cm. approx. of motor oil (Fig. 87).

WARNING

For start-up at low temperatures never use additives such as petrol, ether for paint, gas or other volatile liquids as they would cause serious damage to the engine.

CAUTION

Keep the rubber cap closed except when adding oil. In fact, when the cap is open impurities, rain and other contaminating elements may get into the engine and cause rapid wear.





ENGINE WITH ELECTRIC START

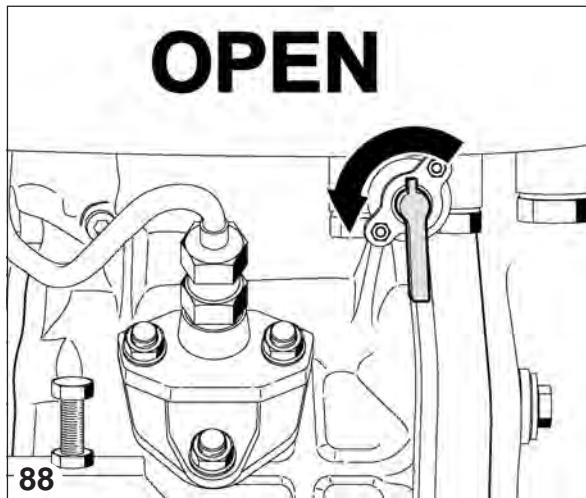

Turn the fuel lever to the “open” position (Fig. 88).

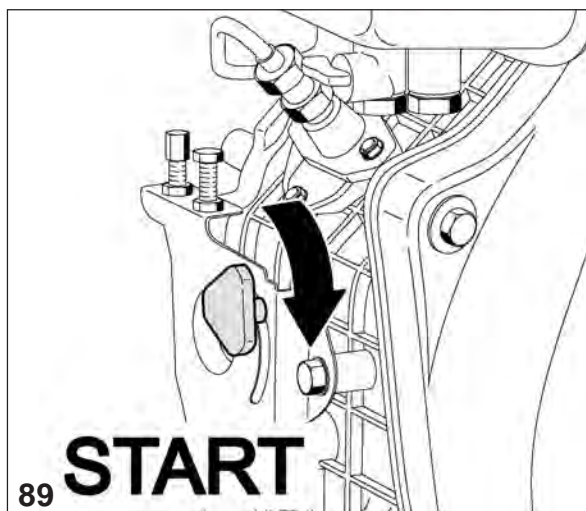

Move the accelerator lever to the “START” position (Fig. 89).

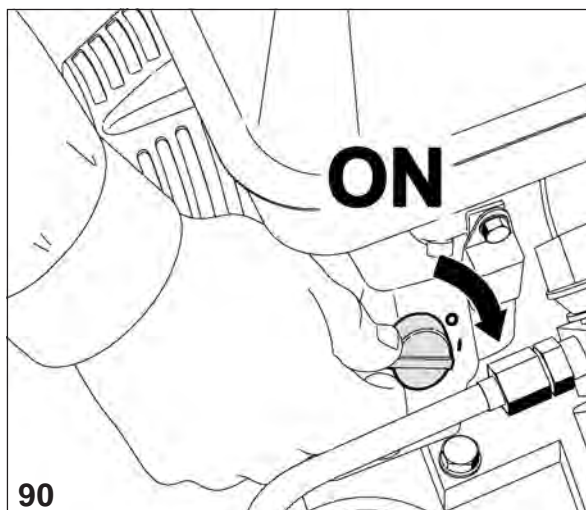

Turn the starter key in a clockwise direction to the “ON” position (Fig. 90). Release the key as soon as the engine starts up.

CAUTION



If the starter motor remains on for too long, the battery goes flat and the starter motor itself may block. When running, always leave the key in the “ON” position.



Move the accelerator control lever into position to obtain the required number of revs (Fig. 91).

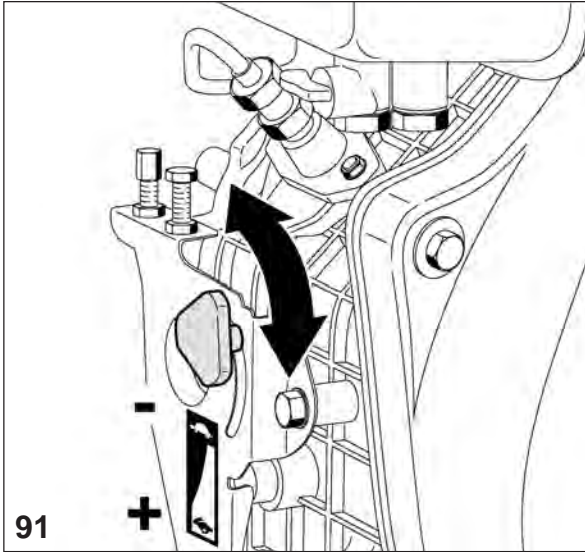

Stopping the internal combustion engine

8.2.4

DANGER

In emergency situations, the engine switch simply has to be moved to the "OFF" position (Fig. 92).



To stop the engine under normal circumstances:

- turn the accelerator lever in an anti-clockwise direction as far as it will go (Fig. 93-94);
- move the engine switch to "OFF" (Fig. 92);

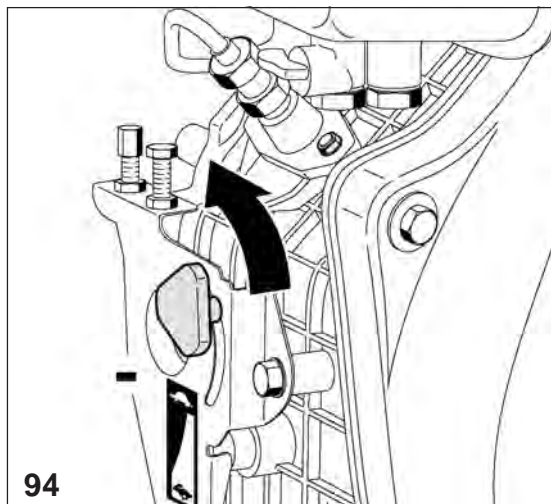
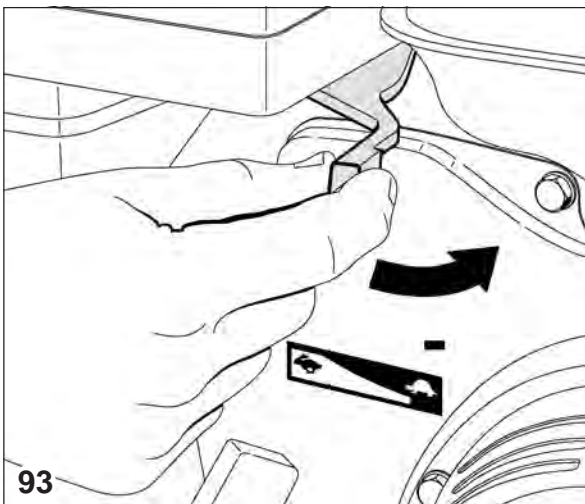
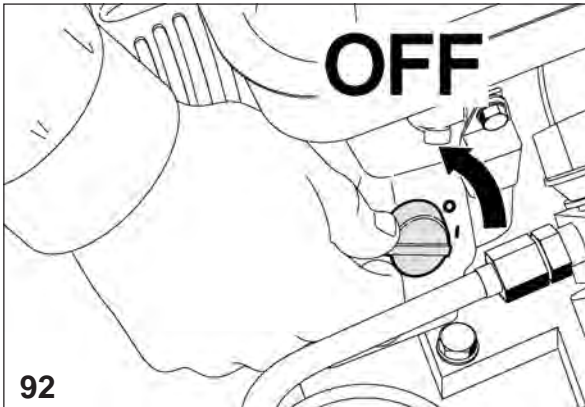

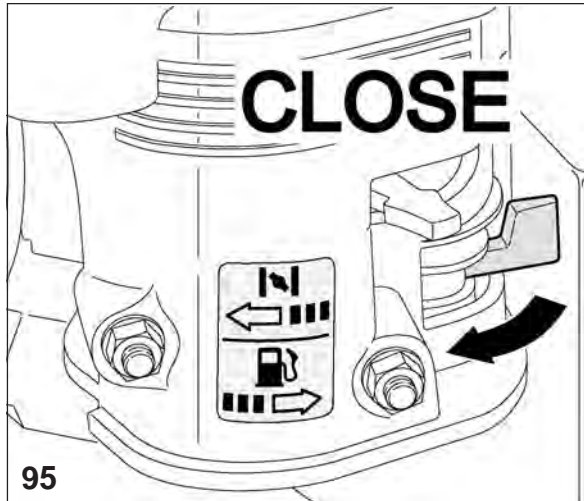

- move the fuel lever to "CLOSE" or "S" according to the model (in a clockwise direction) (Fig. 95-96).

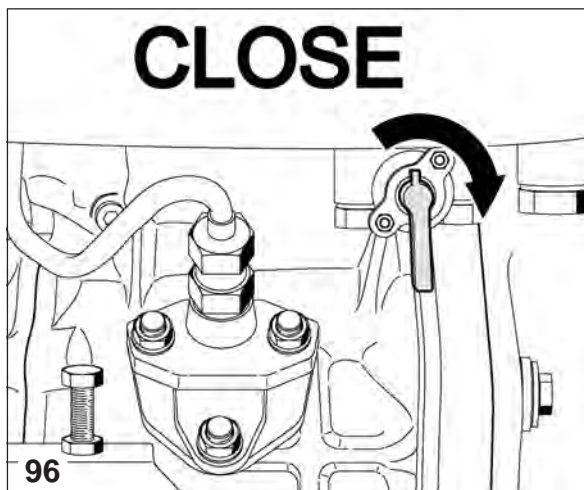

FOR DIESEL ENGINES

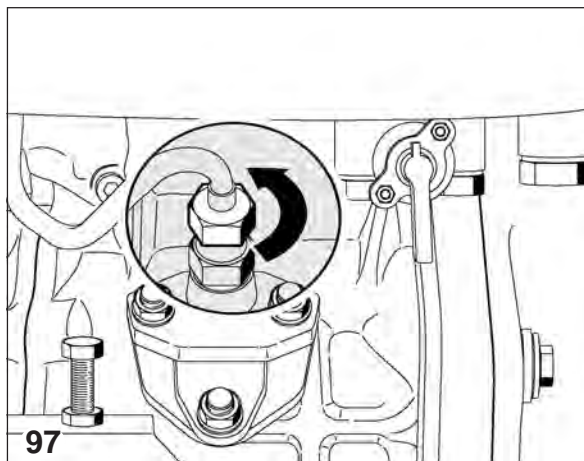

WARNING

If the engine continues running even with the lever in the "STOP" position, the engine must be stopped by closing the fuel cock (position "S") or by loosening the bolt of the high pressure tube on the injection pump (Fig. 97).



USE

9

This chapter describes the operations required for refilling the cylinders.

The following instructions presume that the operator has already become familiar with the precautions given in Chapter 4 "Precautions for use and maintenance" and that the machine has been started up according to the instructions given in the previous chapter.



9.1	Preliminary operations	57
9.2	Refilling the cylinders	58

WARNING

Before proceeding to use the machine as described below, read chapter 4, "Precautions for use and maintenance" very carefully and follow the advice given.

Preliminary operations

9.1

- 1 Check that the safety valve is operating properly by starting up the compressor with the end taps turned off so that the pressure in the circuit rises quickly and the valve comes into operation at the set pressure.

The valve is pre-calibrated in the factory at a pressure of 225 bar or 330 bar.

WARNING

Under no circumstances may the calibration pressure of these valves be increased. Any tampering with the safety valves may cause serious damage to the machine or to persons and a cancellation of the guarantee.

- 2 Check the condition of the cylinders to be filled.

Also refer to the instructions supplied with the cylinders, compiled by the cylinder manufacturers.

DANGER

If the cylinders should show evident signs of internal and/or external corrosion, it is not advisable to proceed with the filling operation, even if they comply with inspection requirements.



WARNING

Only use inspected cylinders provided with the relative approval.

The cylinder operating and filling pressure values are given on the cylinders themselves.

It is prohibited to exceed this refill pressure value.



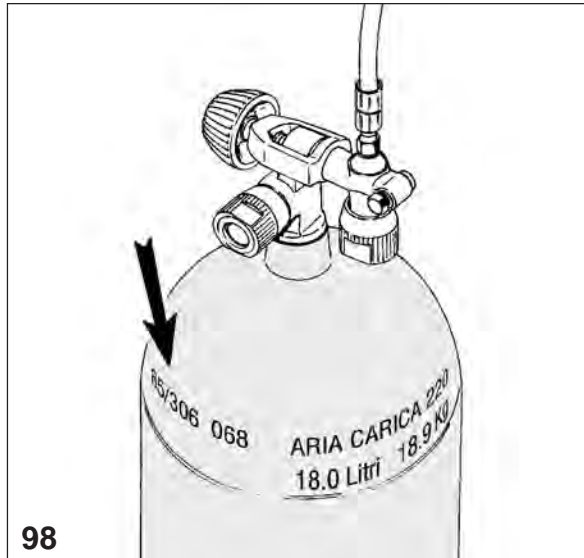

After refilling, the cylinders must not be emptied completely, even during winter storage, to prevent damp air from getting in (Fig. 98).

- 3 Check the condition of the hoses and the relative connectors.
See paragraph 6.2.2 “Connecting the refill hoses”.

CONDENSATE DISCHARGE

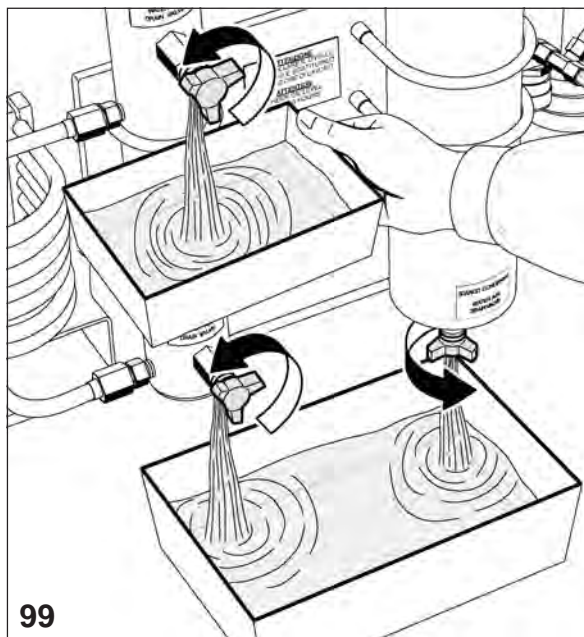

- 4 Place a container under the two condensate snuffle valves and then proceed with the manual discharge by turning on the respective taps (Fig. 99).

This operation should also be carried out during the cylinder refill operations, every 15/20 minutes only on the models without an automatic condensate discharge feature.

9.2 Refilling the cylinders

During this operation, the operator's position is that shown in chapter 3.2 “Noise”.

WARNING

During the refilling of the cylinders it is compulsory for staff who are not involved with the task to keep a distance of at least three metres. Furthermore, it is not permitted to disconnect the hoses from the connectors or from the refill tap while the machine is under pressure.





INDICATION

During the cylinder refill phase, it is advisable to immerse the cylinders in cold water in order to reduce the drop in pressure when the cylinders cool down.

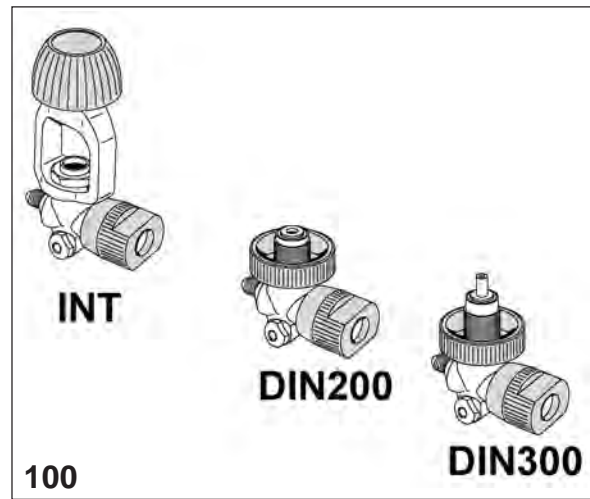

The attachments are disponible: INT - DIN 200 and DIN 300 (Fig. 100).

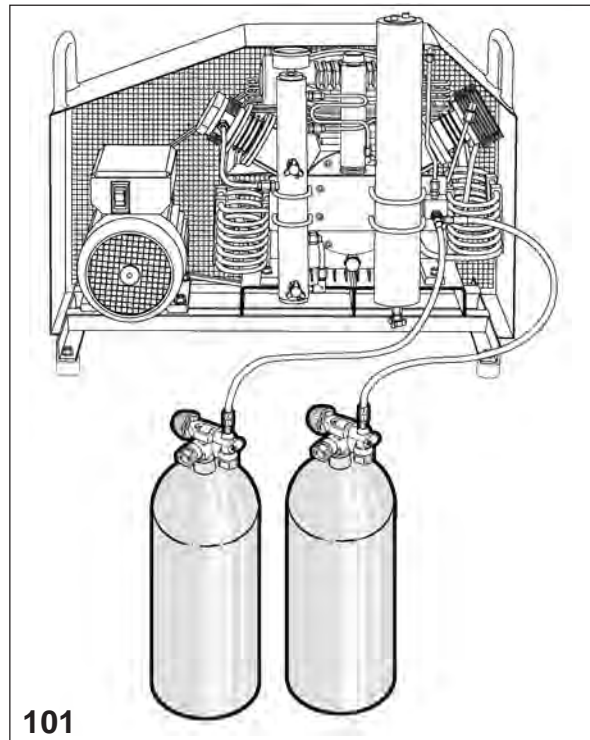

Each refill hose can be connected to a cylinder so that more than one cylinder can be refilled at the same time (Fig. 101).

The following operations must be repeated for each hose to be connected to the cylinder for refilling.

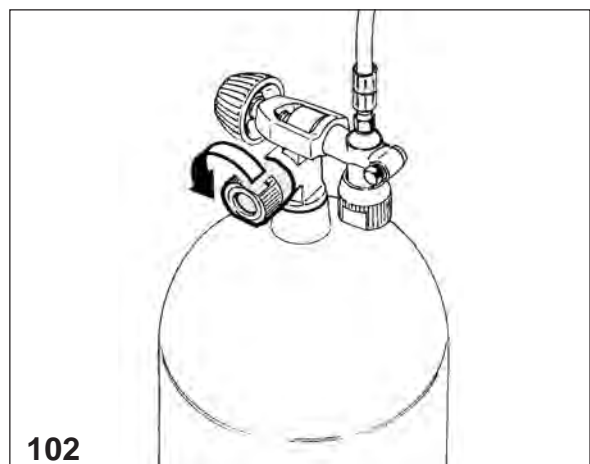

- 1 Fit hose attachment "1" to the cylinder valves and turn on tap "2" (Fig. 102).

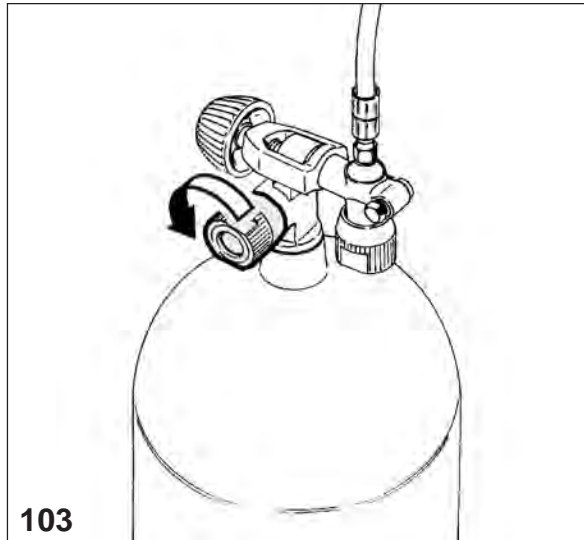

2 Turn on the cylinder tap (Fig. 103).

3 Start up the compressor (see the instructions in chapter 8 “Start-up and stopping”).

4 When the cylinder has been filled, the compressor is stopped automatically by the pressure switch.

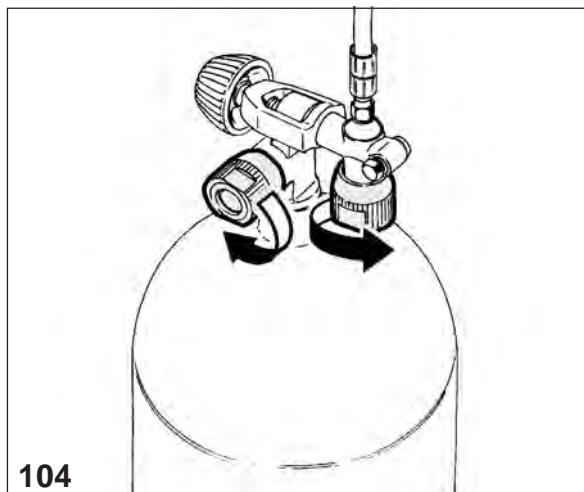

5 Turn off the cylinder tap and that of the hoses (Fig. 104).

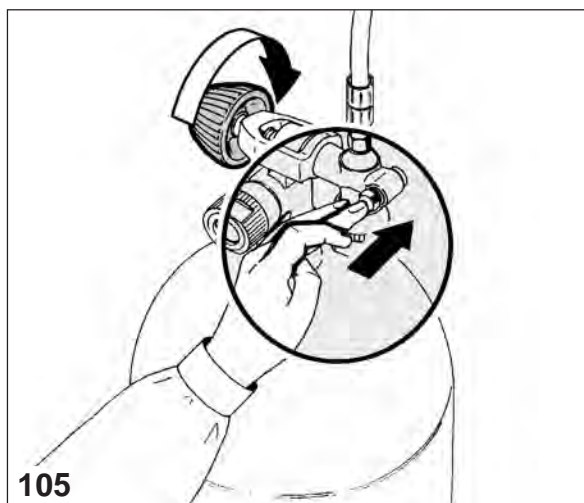

6 Press the pressure bleed button on the refill tap and then disconnect the cylinder attachment (Fig. 105).

If an emergency should arise during the refilling of the cylinder, stop the compressor by pressing the “OFF” button or use the general knife switch.



The machine is, in any case, provided with an emergency system that automatically blocks it when:

- 1) the pressure set is reached;
- 2) there is a temporary cut in the power supply (models with electric power supply);
- 3) the heat release of the electric motor trips due to an overload (models with electric power supply).

After an emergency stop and before proceeding with a subsequent operation, it is necessary to check that the cause of the emergency has been eliminated.



10

PUTTING THE MACHINE OUT OF OPERATION AND DISMANTLING THE MACHINE



This chapter provides instructions to be followed for long machine standstills or for the dismantling of the same.

10.1	Instructions for prolonged machine standstills	62
10.2	Disposal of waste products	66
10.3	Dismantling the machine	66

WARNING



Before carrying out any procedure on the machine, read Chapter 4, "Precautions for use and maintenance" with care.

10.1

Instructions for prolonged machine standstills

If the compressor is not to be used for prolonged periods, remove the active carbon cartridge from the strainer filter.

Run the compressor idle for a few minutes to drain off any residue condensate. Stop the compressor, remove the intake filter, start up the compressor again spraying a few drops of oil into the intake hole so that a light film of lubricant is sucked in and penetrates the internal parts of the compressor. Stop the compressor and refit the intake air filter. Clean the external parts and try to remove any saline humidity and oily deposits. Protect the compressor from dust and water by storing it in a clean, dry place.

Turn the machine off using the general switch (position "0") and remove the power plug.

Carry out a general cleaning operation on the machine and all its components.

MODELS WITH INTERNAL COMBUSTION ENGINES

The "**Standard**" series of compressors run by diesel or petrol engines require additional precautions due mainly to the presence of the fuel, especially if the compressor has to be moved from its place of use.

In these cases, apart from the operations to be carried out on the pump unit, it is also necessary to take the following steps.

NOTE



When the compressor is transported, close the fuel cock on the engine and keep the refill station in a vertical position at all times to avoid spilling any fuel. Risk of fire or explosion.

The place where the refill station is to be stored must be a dry, clean and covered location.

NOTE

The fuels are highly inflammable and may explode. Keep flames and objects producing sparks at a distance. Do not smoke in the surrounding area.



PETROL ENGINES

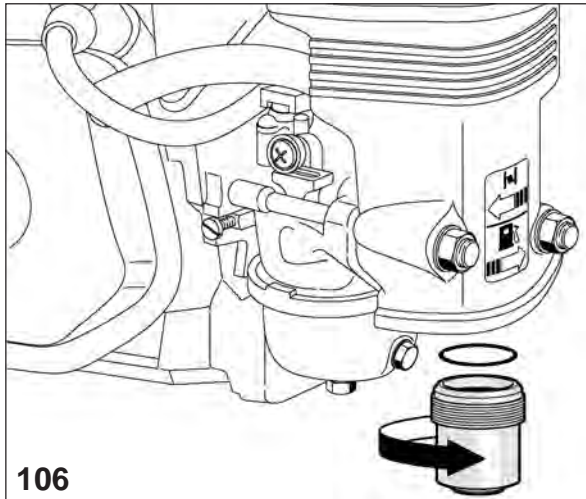

- a) With the fuel cock closed, remove and empty the sump of all sediment (Fig. 106).

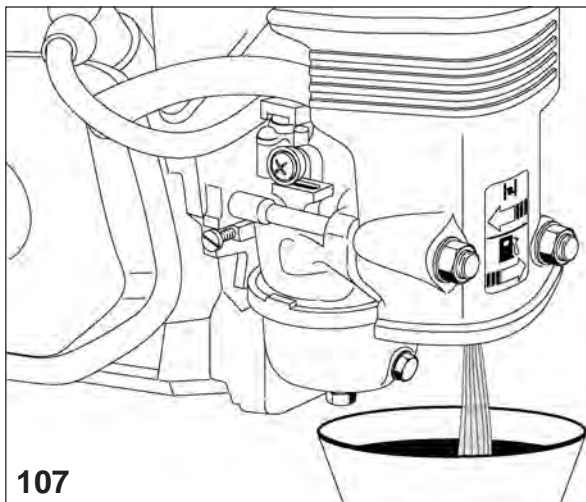

- b) Open the fuel cock and discharge the fuel from the tank into a suitable container (Fig. 107).

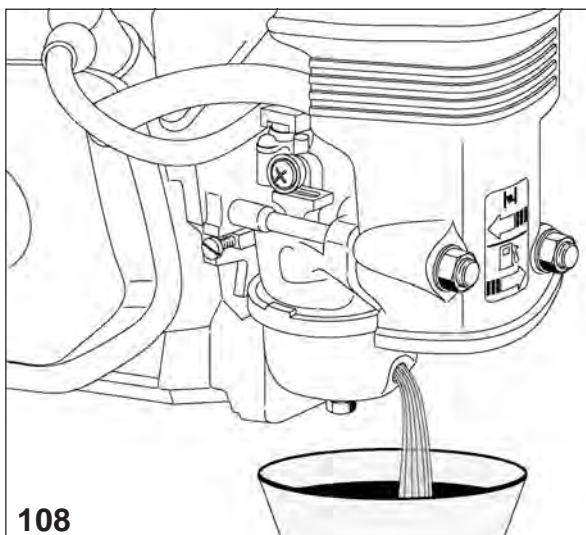

- c) Replace the sediment sump and secure it tightly. Discharge the fuel by unscrewing the discharge screw (Fig. 108). Discharge the fuel from the carburettor into a suitable container.



d) Change the engine oil following the instructions given in chapter 11 "Maintenance".

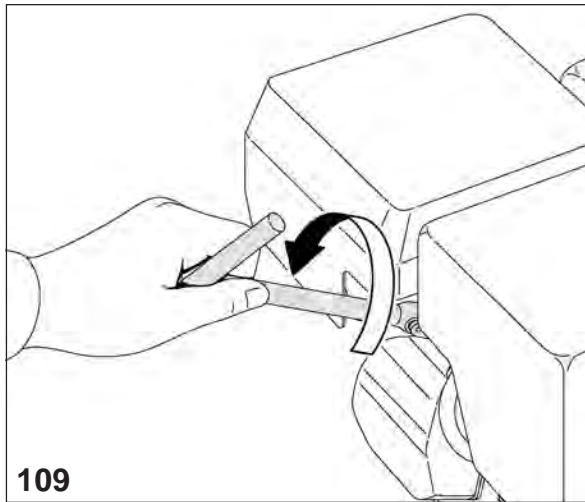

Remove the spark plug (Fig. 109) and pour a spoon of clean motor oil into the cylinder.

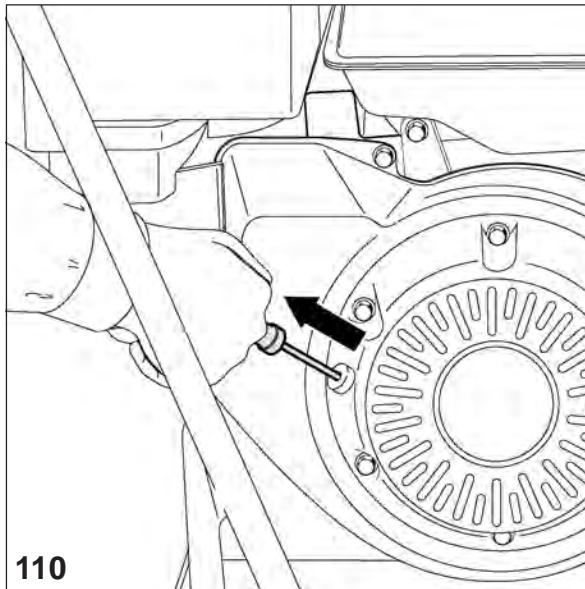

Allow the engine to turn a few times to distribute the oil and then replace the spark plug.

Blow the pull start cord (Fig. 110) until resistance is felt.

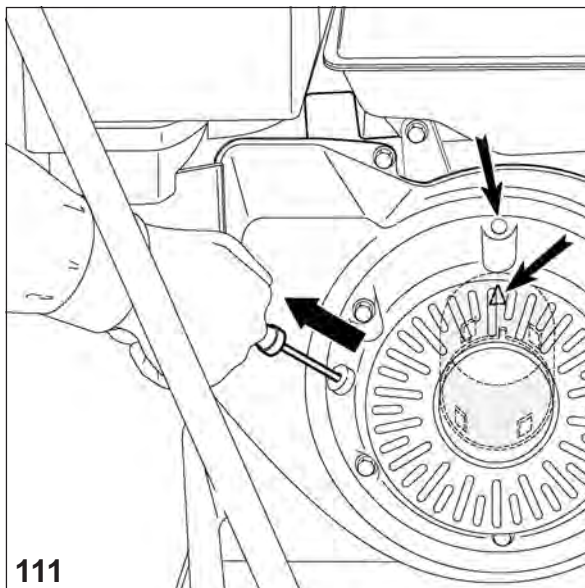

Continue to pull until the notch in the pulley lines up with the hole in the pull start (see the illustration in figure 111). At this point, the suction and discharge valves are closed and this helps to protect the engine from internal corrosion.



DIESEL ENGINES

- a) Run the engine for about 3 minutes and then stop it.
- b) When the engine has stopped, change the lubrication oil while the engine is still hot (see chapter 11 "Maintenance" for the procedures).

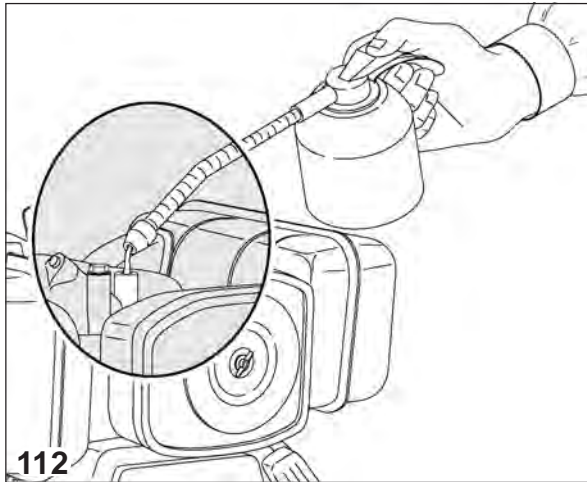

- c) Remove the rubber cap on the equalizer cover and add about 2 cu. cm. of lubricating oil (Fig. 112). Close the rubber cap again.

PULL START

- d) Turn the decompression lever downwards (Fig. 113) (non-compression position) and keep it in this position while the start device is operated 2 or 3 times (the engine does not start up).

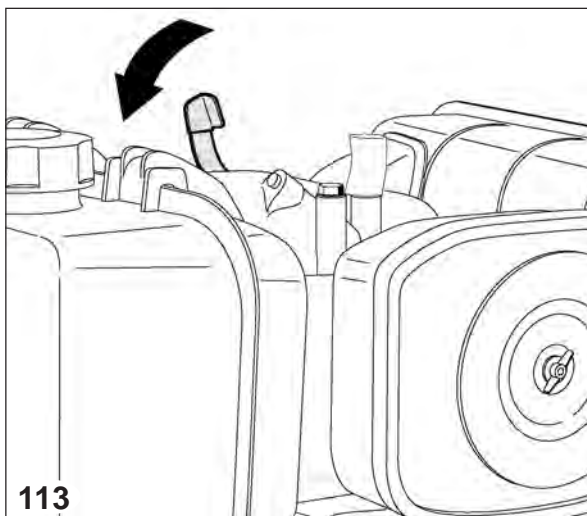

ELECTRIC START

- d) Turn the starter motor for 2 or 3 seconds with the decompression lever lowered (Fig. 113) (non-compression position) and the starter key in the "START" position (the engine does not start up).
- e) Turn the decompression lever upwards, pull the handle of the self-winding device slowly until a strong resistance is felt. This causes the closure of the suction and discharge valves (compression phase), reducing the risk of rust formation.
- f) Remove any mud, oil, etc. from the surface of the engine and position it in a dry place.

MODEL WITH ELECTRIC START

Remove the battery and store it in a cool, dry place. Recharge it once a month.



10.2 Disposal of waste products

When using the compressor, **special waste products** are produced. It must be remembered that waste from industrial processes, agricultural, artisan and commercial activities and service industries cannot be disposed of together with normal urban waste either because of their quality or quantity. Old or obsolete machinery is also to be considered as special waste.

Special care must be taken with the disposal of worn active carbon filters which, being a waste product that cannot be disposed of together with normal urban waste, must be dealt with in compliance with the laws in force in the country where the compressor is installed.

It is important to remember that the loading and discharge of waste oil, special waste products and toxic or harmful waste products deriving from industrial or artisan processes must be registered.

The collection of waste oils and special toxic or harmful waste products must be carried out by specially authorized companies. The disposal of waste oils in particular must be carried out in accordance with the regulations in force in the user's country.

10.3 Dismantling the machine

The operations required for stripping and demolishing the machine must be carried out by qualified staff.

To dismantle the machine, follow the regulations imposed by the laws in force in the user's country. Before demolishing the machine, an inspection must be requested by the competent authority with the issuing of a relative report. Disconnect the machine from the power supply.

Remove any interfacing that there may be between the compressor and other machines, checking carefully that any interfacing between other machines that are still in use remain operative.

Empty the tanks containing the lubricating oil or fuel (models with internal combustion engines). The oil or fuel must be stored in accordance with the provisions of the law.

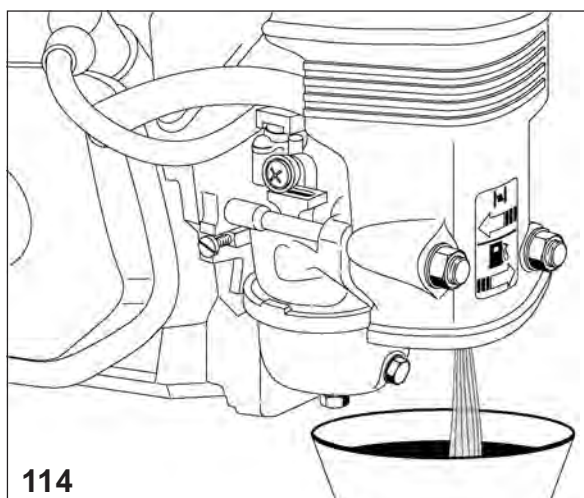

Furthermore, for models run by internal combustion engines (MCH 13-16/SH, MCH 13-16/DY, MCH 13-16/DH):

PETROL ENGINES

- open the fuel cock and discharge the fuel from the tank into a suitable container (Fig. 114).

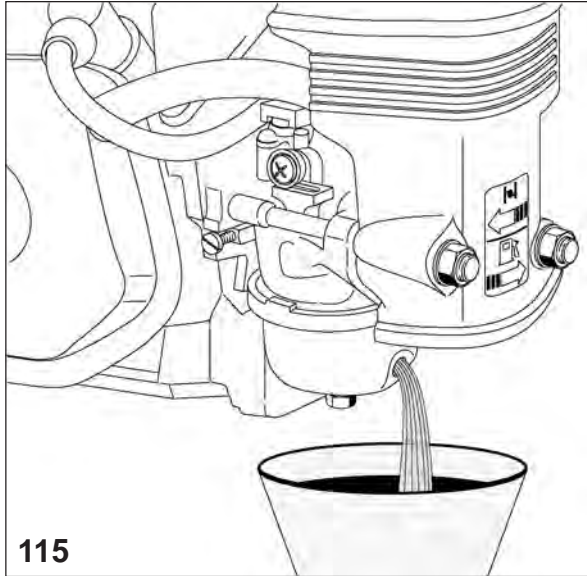

- Discharge the carburettor by unscrewing the discharge screw and using a suitable container (Fig. 115).

- Discharge the engine oil.

Proceed with the disassembly of the individual machine components grouping them together according to their composition. The machine consists mainly of parts made of steel, stainless steel, cast iron, aluminium and plastic material.

Finally, proceed with the disposal of the parts according to the laws in force in the user's country.

During all the phases of demolition, comply carefully with the safety warnings given in this manual.



11

MAINTENANCE



This chapter includes instructions concerning the preventive, routine and additional maintenance operations.

In the specifications for the preventive maintenance operations for the various devices indication is also given of the frequency of such procedures.

Before consulting the chapter, read Chapter 4 "Precautions for use and maintenance" with care.

- 11.1 **General notes** 69
- 11.2 **Preventive maintenance** 69
- 11.3 **Changing the lubricant oil** 70
- 11.4 **Checking the transmission belt** 71
- 11.5 **Air intake filter** 73
- 11.6 **Active carbon filter and molecular sieve** 74
- 11.7 **Refill hose** 76
- 11.8 **Intake and discharge valves** 77
- 11.9 **Heads** 77
- 11.10 **Cylinders** 78
- 11.11 **Internal combustion engines** 79
 - 11.11.1 **Maintenance programme** 79
 - 11.11.2 **Oil change** 80
 - 11.11.3 **Air filter** 81
 - 11.11.4 **Sediment sump (only for petrol engines)** 82
 - 11.11.5 **Spark plugs (only for petrol engines)** 83
 - 11.11.6 **Minimum carburettor regulation (only petrol engines)** 85
 - 11.11.7 **Fuel filter** 85
 - 11.11.8 **Battery 12 Volt (not supplied by Aerotecnica Coltri)** 86
- 11.2 **Maintenance operations** 88

WARNING

All the routine and additional maintenance operations must be carried out with the machine at a standstill (the compressor at a standstill) and with the power supply disconnected.

The residue pressure in the machine (pump circuit) must be eliminated.

Any operation carried out on the machine must only be undertaken having read and carefully applied the regulations listed in Chapter 4 "Precautions for use and maintenance".



General notes

11.1

To keep the machine in good working condition, it must be cleaned very thoroughly.

Having been designed and built according to the most advanced technological criteria, this type of refill station requires very limited preventive and routine maintenance operations.

However, it is essential to follow the indications given in this chapter very carefully and to follow the intervals between operations as suggested. During the guarantee period no responsibility is taken for any damage or operating faults due to a failure to comply with the regulations in force.

The following paragraph enables all the routine and additional maintenance operations carried out on the machine to be recorded. This paragraph should be filled in carefully and any operations carried out to solve problems should also be reported.

Preventive maintenance (Table 1)

11.2

Table 1

		INTERVALS										
		X	1 day	15 min	30 min	25 h	50 h	125 h	250 h	500 h	1000 h	5000 h
1	Replace the active carbon cartridge, see par. 11.7						○					
2	Check the compressor oil level						○					
3	First compressor oil change					●						
4	Change compressor oil								●			
5	Intake filter cartridge					○		●				
6	Operation of the end safety valve					○						
7	Operation and tightness of the refill valve					○						
8	Alignment of the compressor needle with the ○ when the compressor is depressurized					○						
9	Tightening of the cooling pipes							○				
10	Tightening of the connecting pipes							○				
11	Belt tension and wear								○		●	
12	Hose replacement										●	
13	2 nd and 3 rd stage intake and discharge valves									●		
14	Internal cleaning of end separator								○			
15	Tightening of all the screws								○			
16	General cleaning								○			
17	Replacement of the external casing of the strainer filter											●
18	Replacement of 1 st stage head										●	

●= replacement

○= inspection, cleaning



11.3 Changing the lubricant oil (Table 2)

The quantity of oil for the lubrication of the pump unit must be checked every 25 hours.

To carry out this operation, see chapter 8 "Start and stop".

The oil must be changed every 250 operating hours or yearly.

When changing the oil, it must be remembered that a mixture of different oils cannot be used.

The oil must have the following characteristics:

Table 2

Sump capacity	cu.cm. litres/gallons	1500 1.5/0.476
Recommended oils		AEROTECNICA COLTRI SPECIAL MINERAL OIL AEROTECNICA COLTRI SPECIAL SYNTHETIC OIL MOBIL SPECIAL 20 W 50 MOBIL RARUS 827-829 ANDEROL 755 SYNTHETIC
Viscosity of the oil	summer winter	above +10 °C (50 °F) SAE 20 W/40 from +10 °C to -15 °C (50° to 5 °F) SAE 10 W below -15 °C (5 °F) SAE 5 W
Maximum tilt of the compressor with the oil level at maximum	degrees	~ 5

To change the oil, proceed as follows:

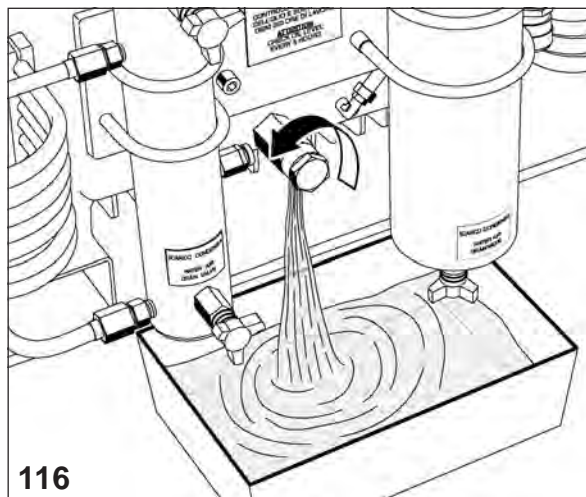

- 1 Use a basin with a minimum capacity of 2.5 lt. capacity under the oil discharge tap (Fig. 116).

- 2 Unscrew the hexagonal closing cap located in front of the oil discharge and discharge all the oil in the sump.
- 3 Replace the hexagonal closing cap.
- 4 Carry out the filling operations as described in chapter 8 "Start and stop".

WARNING

To dispose of waste oils follow the instructions given in chapter 10.2 "Disposal of waste products" with great care.



Checking the transmission belt

11.4

The drive belt control involves measuring the flex herself.

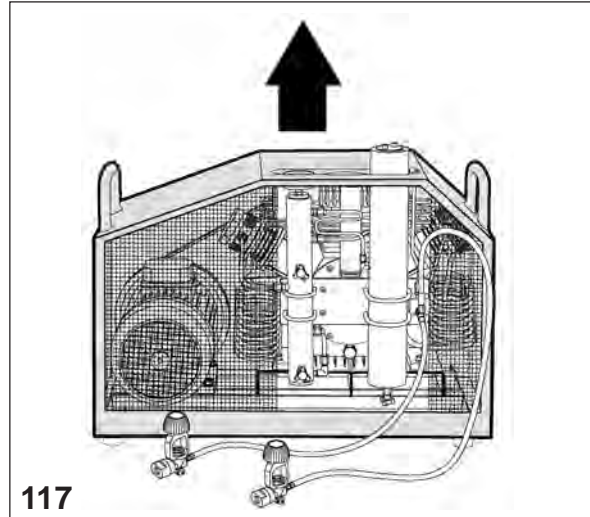

This operation must be carried out every 250 machine operating hours as described below:

- 1 Remove the protective cover as shown on figures 117, 118 and 119, by unscrewing the fixing screws.

MCH 13-16/ETC STANDARD

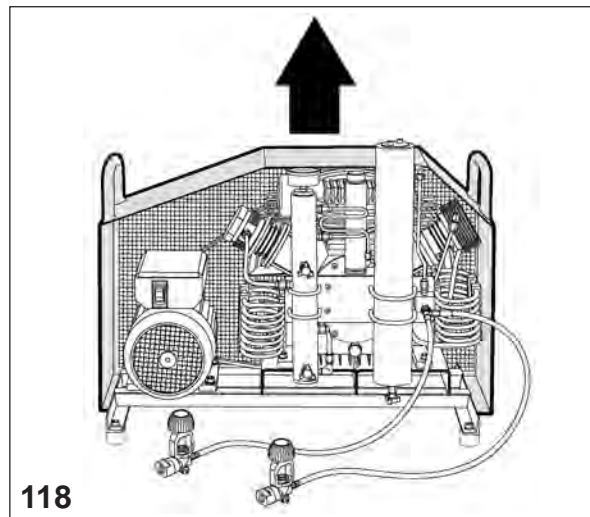

MCH 8/EM STANDARD
MCH 13-16/ET STANDARD

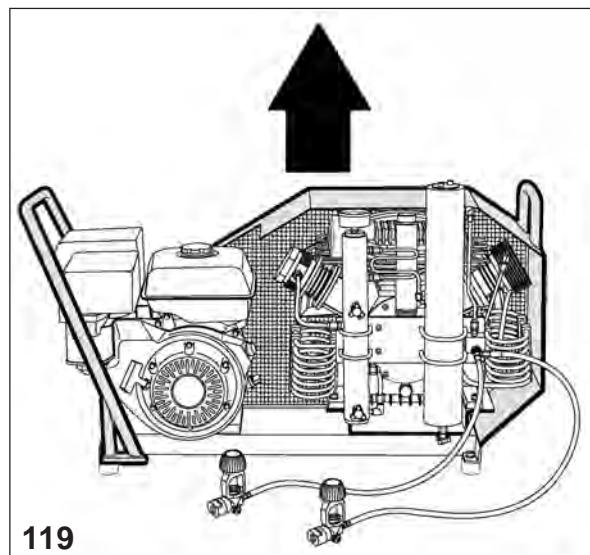

MCH 13-16/SH
MCH 13-16/DY
MCH 13-16/DH

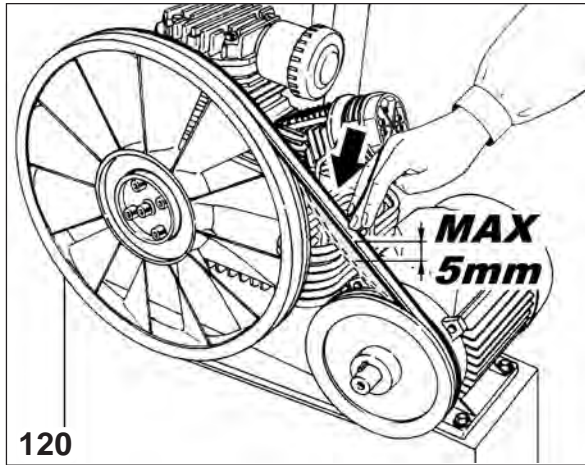

120

- 2 By exerting a pressure of at least 5 Kg., check that the belt does not flex by more than 5 mm. compared to its original position (Fig. 120-121).

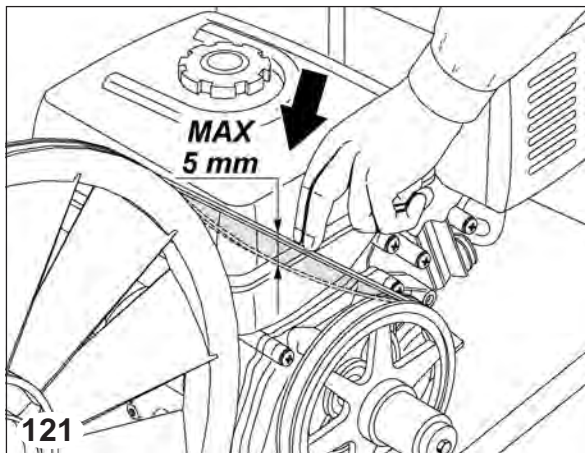

121

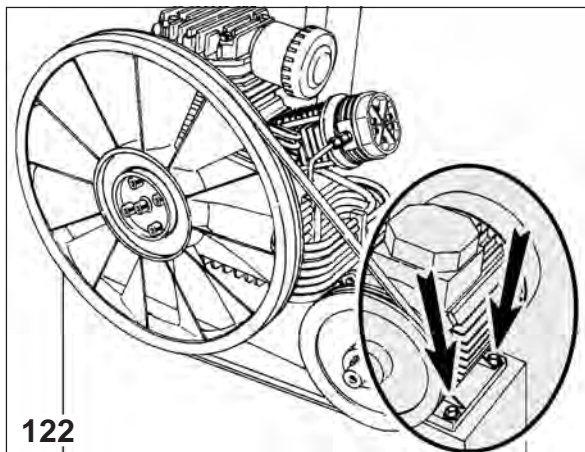

122

If this distance should exceed 5 mm., intervene by loosening the motor fastening screws (Fig. 122-123), remove the driving belt and move the motor away from the compressor by a few millimetres by sliding it along the slots.

Tighten the motor fastening screws.

Refit the belt, placing it in the race provided in the motor pulley and in the innermost race of the fan, turning it by hand to enable the belt to go over the diameter of the fan and to fit into the race.

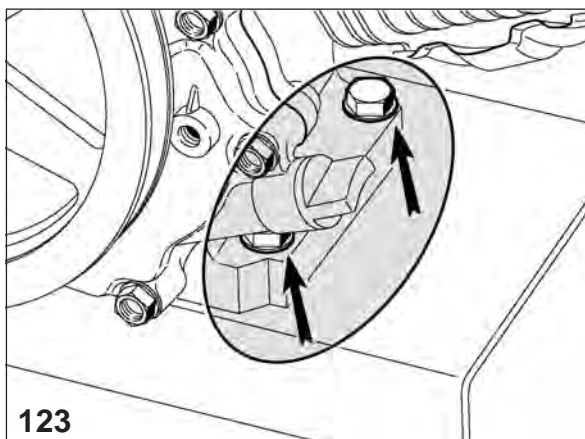

123

- 3 Carry out the measurement procedure again and if necessary, repeat the operations until a maximum distance of 5 mm. is reached.
- 4 Replace the covers securing the appropriate screws tightly (see point 1).

Air intake filter

11.5

The intake filter must be checked to make sure it is in good order every 25 operating hours.

The filter is cleaned by blowing air inside the cartridge when it has been removed.

Replace the cartridge turning it by 60° compared to its initial position.

MCH 13-16/ETC Standard

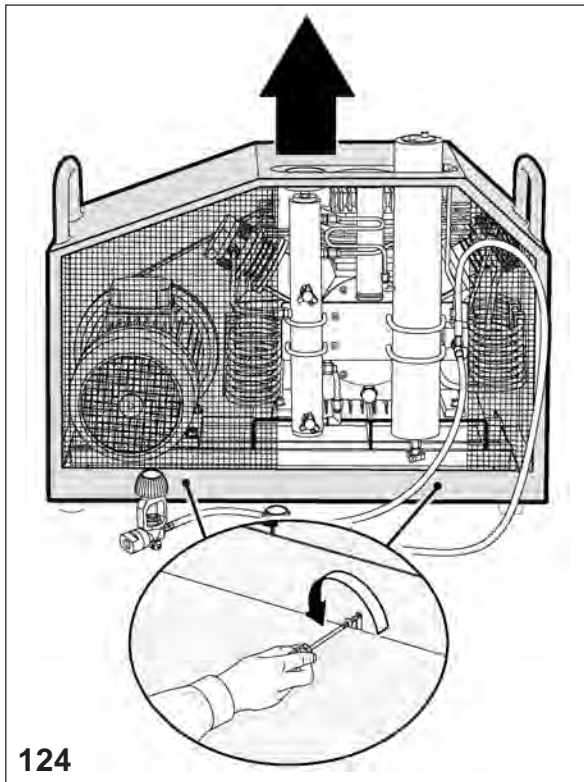

The filter must be replaced every 125 operating hours with the following procedure:

MCH 13-16/ETC Standard

- 1 Remove the protection guard by unscrewing the fastening screws (Fig. 124).

NOTE: for all the other models it is not necessary to remove the protection guard.

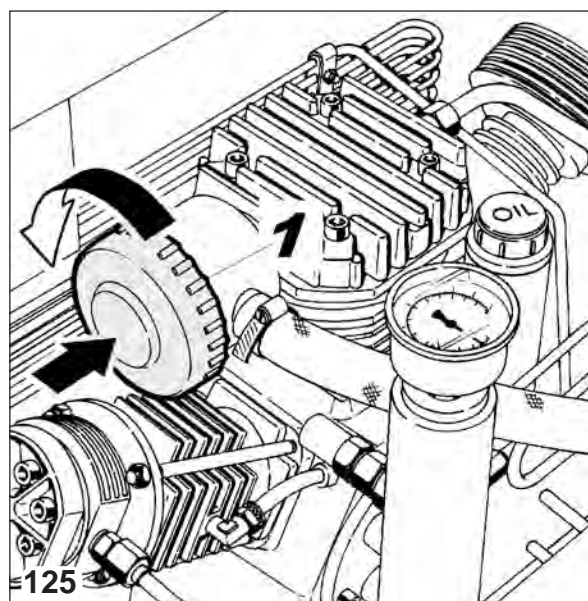

- 2 Press cap n° 1 lightly and turn it in an anti-clockwise direction (Fig. 125).

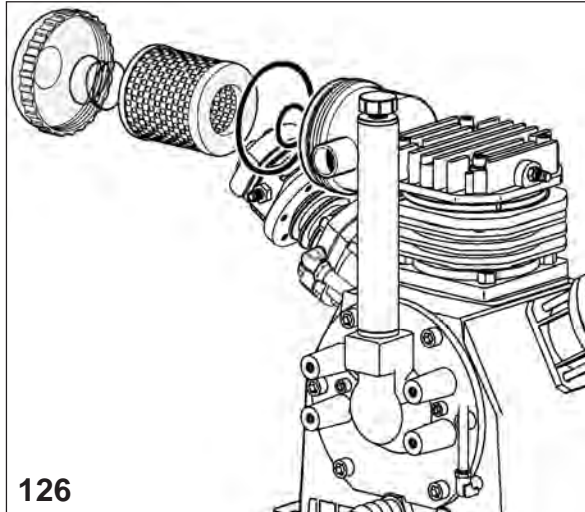

3 Remove the filter and replace it with a new one (Fig. 126).

To order a new spare filter, refer to chapter 14 "Spare parts".

4 Replace the protection guards if they were removed securing them in place with the screws provided (see point 1).

11.6 Active carbon filter and molecular sieve

The cartridges must be replaced before the air becomes foul-smelling.

The quality of the air depends to a large extent on the condition of the filtering cartridge. For this reason, it is important to comply with the intervals as specified.

The frequency of replacement has been calculated for use of the compressor with intake air at a temperature of 20 °C (68 °F), see table 4. If the temperatures differ, apply the coefficients given in the following table 3 to the duration of the filter:

Table 3

°C	°F	Multiplicative coefficients
50	122	0.20
40	104	0.34
30	86	0.57
20	68	1
10	50	1.85
5	41	2.60
0	32	3.80



Table 4

MODEL	N° OF 10 LITRE CYLINDERS TO BE REFILLED		VOLUME OF FILTERED AIR cu.m.	DURATION OF THE FILTER hours
	200 bar	300 bar		
MCH 8/EM	322	214	644	80
MCH 13/ETC	322	214	644	50
MCH 16/ETC	322	214	644	50
MCH 13/ET	322	214	644	50
MCH 16/ET	322	214	644	50
MCH 13/SH	322	214	644	50
MCH 16/SH	322	214	644	50
MCH 13/DY	222	214	644	50
MCH 16/DY	222	214	644	50
MCH 13/DH	322	214	644	50
MCH 16/DH	322	214	644	50

Check the sealing O-Rings and replace them if they are damaged.

Leave the cartridge in the filter when the compressor is not in use.

Maintain a pressure of 40-70 bar inside the filter to prevent outside dampness from getting in.

To replace the active carbon filter, proceed as follows:

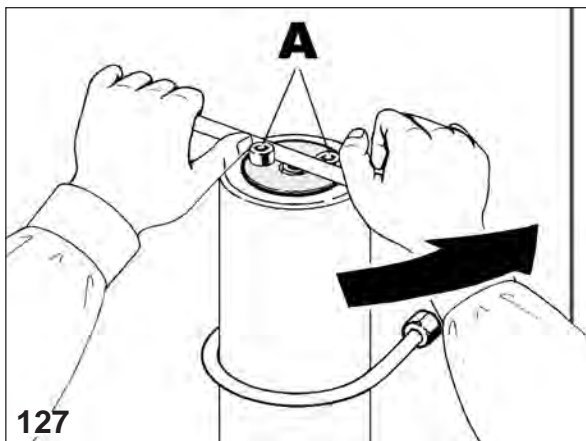

- unscrew the external cap using a lever between the screws "A" (Fig. 127);

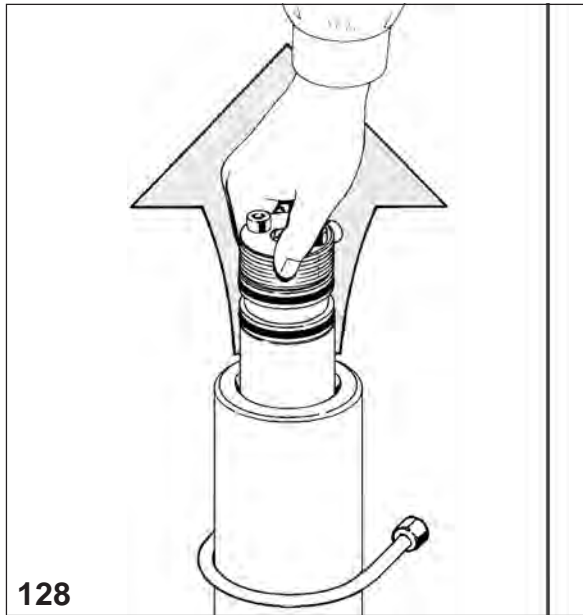

- remove the external cap and the internal cap (Fig. 128);

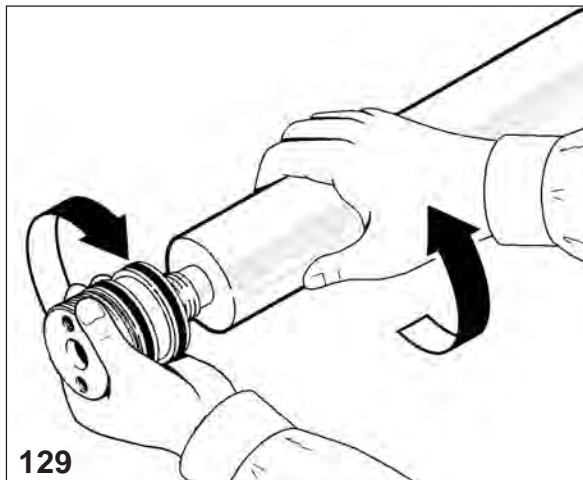

- unscrew the used cartridge from the internal cap (Fig. 129) and then screw in the new one;

- screw up the internal cap having lubricated or replaced the sealing O-Rings if they are worn and having lubricated the threads of the external cap using silicone grease.

WARNING



The used active carbon filter cannot be disposed of together with urban waste. To dispose of the active carbon filter, follow the instructions given in chapter 10.2, "Disposal of waste products" with great care.

11.7 Refill hose

The refill hose must be in good condition especially in the area of the connections.

The plastic sheath that covers the hose must not show any signs of abrasion otherwise if any humidity infiltrates, it could corrode the steel plait and reduce its resistance. The hose must be replaced periodically (annually) and/or when it shows signs of wear. Failure to comply with this regulation could cause serious danger to the operators. Make sure that the minimum radius of curvature of the hose is not less than 250 mm. To connect the hose, follow the instructions given in chapter 6.2.2, "Connecting the refill hose".

Intake and discharge valves

11.8

The 2nd stage intake valve can be removed for maintenance purposes while those of the 1st, 2nd (only discharge) and 3rd stages must be entirely replaced. The seats must be cleaned carefully using petrol and soft brass or nylon brushes.

The torque wrench setting for the head bolts of the 3rd stage is initially 1 Kgm. Having moved the head closer, tighten the bolts to 2.2 Kgm, making sure that the piston is at the bottom dead centre during the operation.

Avoid using steel brushes or screwdrivers. The interval between maintenance operations is 400-600 working hours. If any parts are damaged or worn, they must be replaced. The discharge valves can be removed from the outside while the intake valves can only be removed when the head of the cylinder has been taken off.

NOTE: the valve replacement procedure must be carried out at the work bench by specialized technicians who have specific equipment for the stripping operation.

In any case, it is preferable to contact **AEROTECNICA COLTRI S.r.l.** who will supply the necessary technical assistance.

Heads

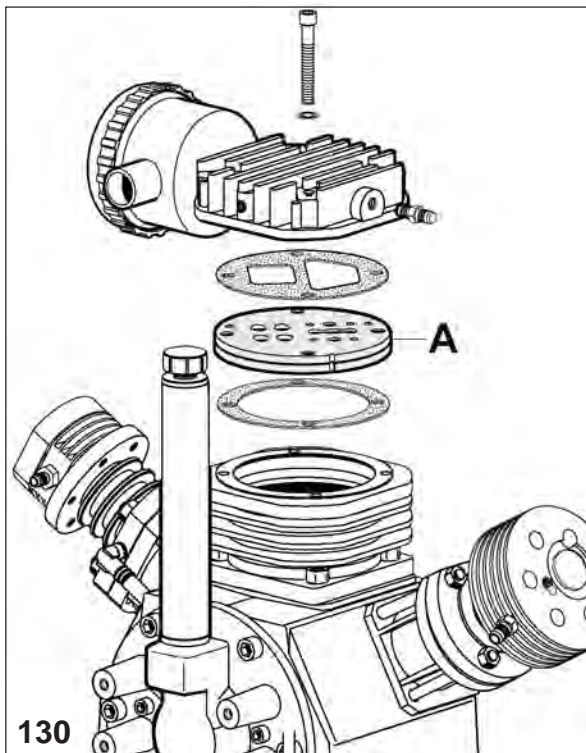
11.9

- The head of the 1st stage (A) is of the lamellar type (Fig. 130). It must be fitted so that the word "TOP" remains upwards and the flaps correspond with the openings in the cover of the head. Replace every 1000 hours.

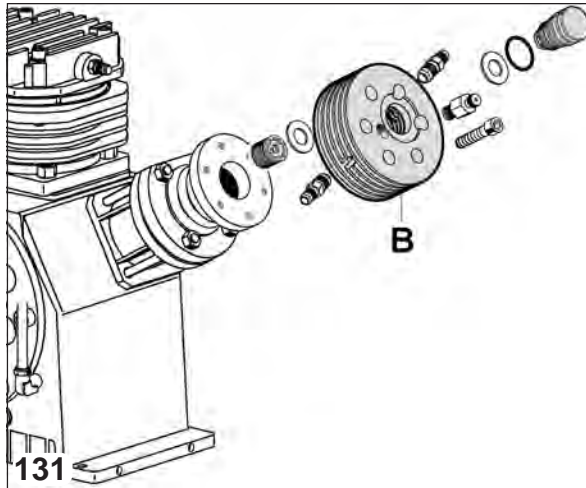

- The head of the 2nd stage (B) is made of aluminium (Fig. 131), the valves are screwed in; the intake valve inside is removed using a special pin wrench while the discharge valve is on the outside and is removed with a non-adjustable wrench or a box wrench.

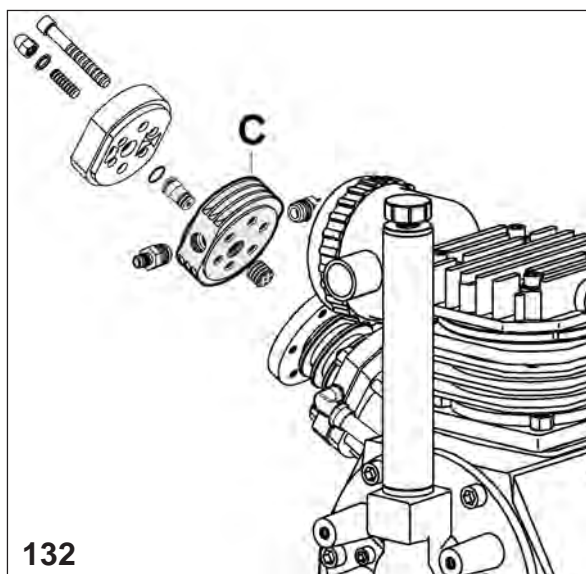

- The head of the 3rd stage (C) is made of aluminium (Fig. 132), the intake valve is screwed inside and is removed using a special pin wrench while the discharge valve is on the outside and is kept in position by the threaded dowel which is screwed into the cover.

11.10 Cylinders

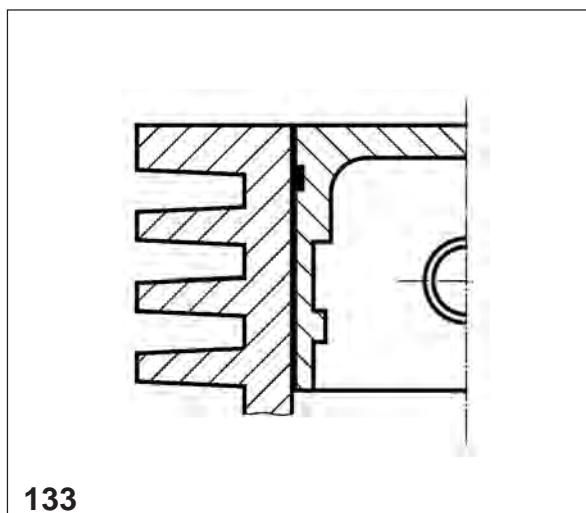

After removing the cylinders, it is necessary to check, when they are replaced, that the piston at the maximum point and the upper edge of the cylinder are on the same level (Fig. 133).

Adjust any differences that there may be by making the base of the cylinder thicker using gaskets.



Internal combustion engines

11.11

The compressors are supplied with an instruction manual compiled by the engine manufacturer. In case of doubt or for further information, refer to the specific engine manual.

WARNING

Carry out all the operations described below either with the engine turned off or cold.



The intervals at which maintenance has to be carried out are shown in table 5.

Maintenance programme

11.11.1

Table 5

INTERVAL FOR PERIODIC SERVICING To be carried out at the intervals or after the number of operating hours shown, whichever occurs first.		At each use	First month or 20 hours	Every 3 months or 50 hours	Every 6 months or 100 hours	Every year or 300 hours
UNIT	OPERATION					
Engine oil	Check level	○				
	Change		○	○		
Air filter	Check	○				
	Clean			○(1)	Replacement	
Sediment sump	Clean				○	
Spark plug	Check-clean				○	
Spark arrester (optional)	Clean	○				
Valve clearance	Check-adjustment					○(2)
Fuel tank and filter	Clean			○	Replacement	○(2)
Fuel pipes	Check (and replace if necessary)	Every two years (2)				
Battery	Check	○				

NOTES:

- 1) Service more frequently in dusty areas.
- 2) These parts must be serviced by technical staff authorized by the manufacturer.



11.11.2 Oil change

To ensure that all the oil is discharged, empty it out when the engine is hot.

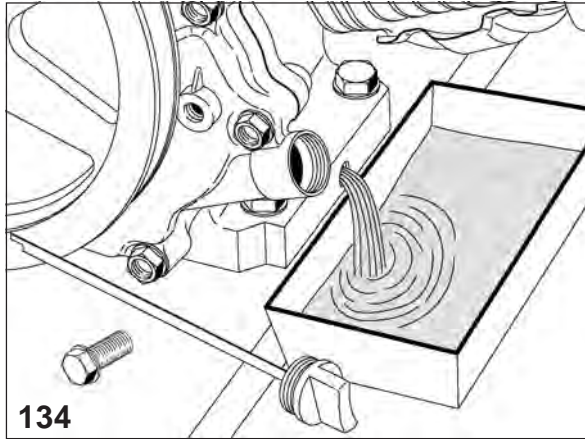

Remove the oil top up cap and the oil discharge cap to discharge the oil (Fig. 134).

Screw up the oil discharge cap again and secure it tightly.

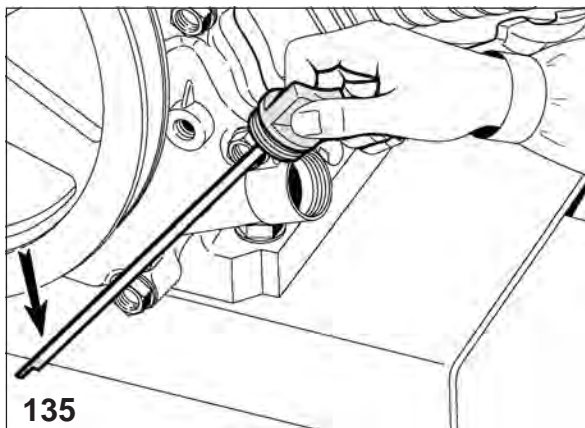

Top up with the type of oil recommended by the manufacturer and check (Fig. 135).

DANGER



If the engine oil comes into constant contact with the skin, it can cause skin cancer. Although this is a very remote possibility except for those who handle engine oil every day, it is still advisable to wash hands well with soap and water as soon as possible after the work has been done.

NOTE:

The used engine oil removed must be disposed of according to the national laws in force concerning such matters. We advise placing it in a sealed container and taking it to a service station for recycling.

WARNING



The oil must be disposed of carefully and not into the environment (e.g. into wells, into the ground, etc.).

Air filter**11.11.3**

If the air filter is dirty, it reduces the flow of air to the carburettor. To prevent damaging the carburettor, service the air filter regularly. It should be serviced even more frequently if the engine is used in very dusty areas.

CAUTION

Never clean the air filter with petrol or very inflammable solvents, otherwise it could lead to explosions or fires.

**WARNING**

Never turn the engine on without the air filter as this would certainly damage it.

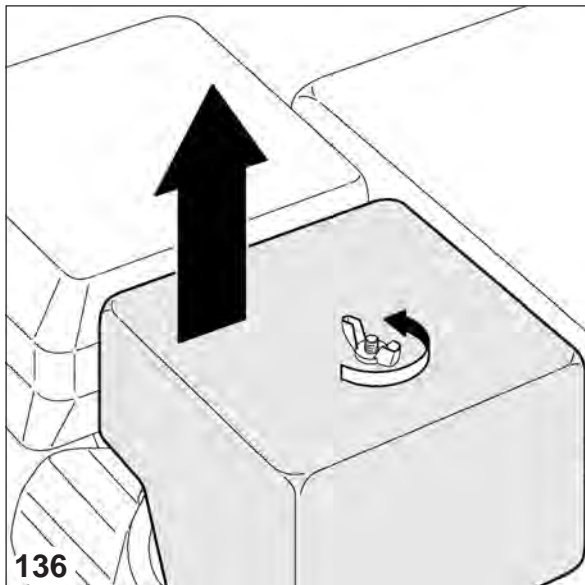
PETROL ENGINE

- 1 Remove the butterfly nut and the air filter cover (Fig. 136-137). Remove the filter parts and separate them. Check the parts carefully to ensure they are not perforated or damaged. If they are, replace them.

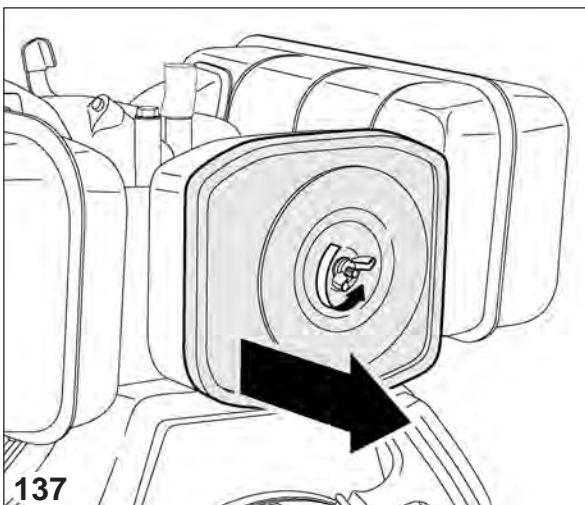
DIESEL ENGINE



PETROL ENGINE

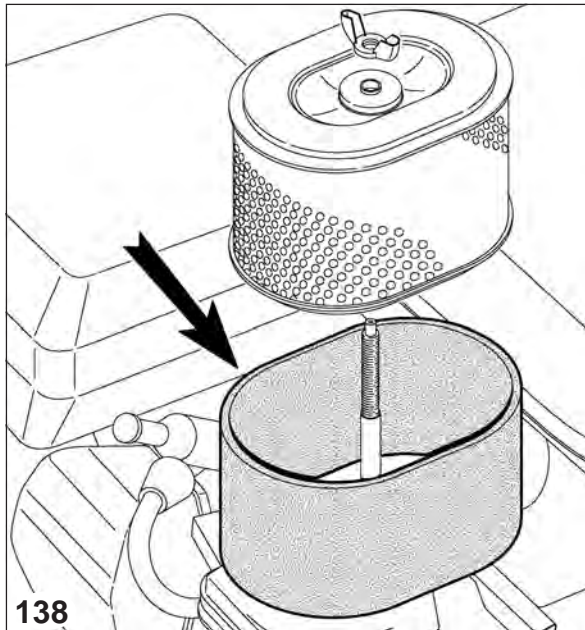

- 2 **Foam part** (Fig. 138): wash the part in a cleansing solution for domestic use and hot water and dry well, or wash it in a solvent that is either not or only slightly inflammable. Then leave it to dry well. Soak the part in clean engine oil and squeeze it to get out all the excess oil.

NOTE:

if too much oil is left in the filter, the engine smokes in a strange way as soon as it is started up.

DIESEL ENGINE

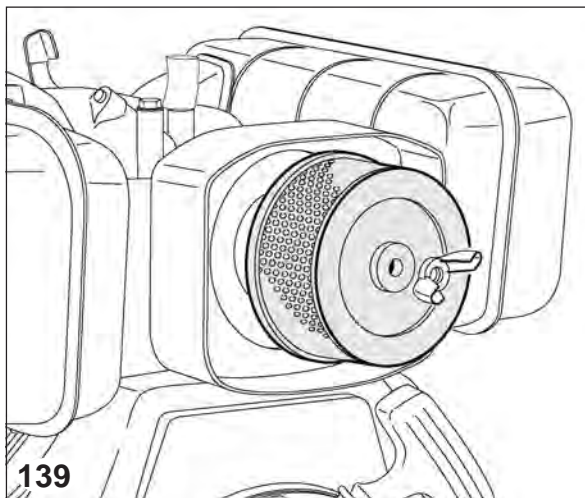

- 3 **Paper part** (Fig. 139): tap the part several times on a hard surface until the dirt is removed. Compressed air may also be blown into it from the inside outwards.

Never use brushes as they push the dirt into the fibres of the part. Replace the paper part if it is too dirty.

11.11.4 Sediment sump (only for petrol engines)

CAUTION



- The fuel is highly inflammable and may even explode. Do not smoke in the surrounding area and do not allow naked flames or sparks near the engine.
- Once the sediment sump has been fitted, check that there are no leaks and that the whole area is free of any spilt fuel before starting the engine.

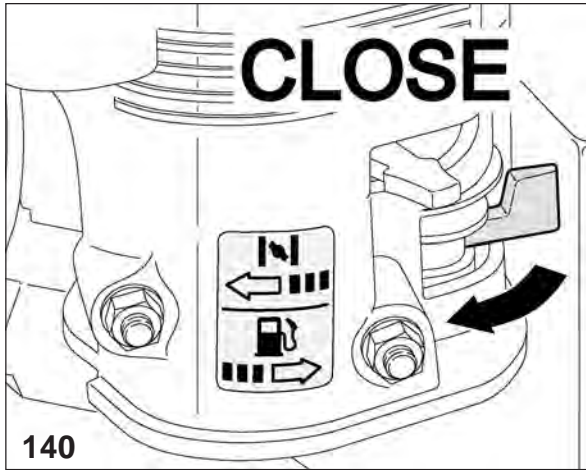

Move the fuel valve to "CLOSE" (Fig. 140). Remove the sediment sump and the "O" ring (Fig. 141), then wash them in solvent that is either non-flammable or only slightly flammable. Leave them to dry well and then replace them. Open the fuel cock and check that it does not leak.

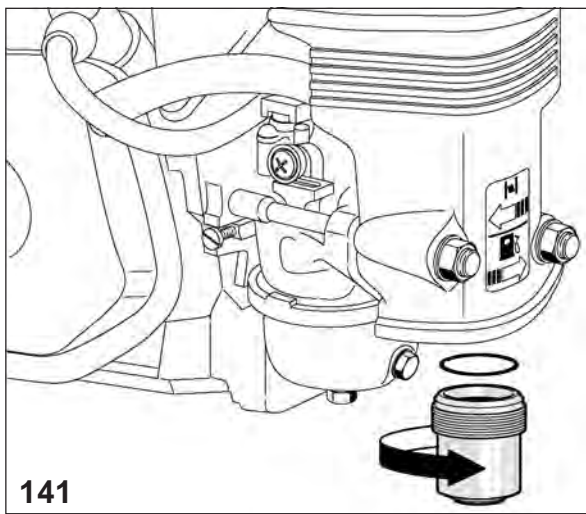

Spark plugs (only for petrol engines)

11.11.5

WARNING

Never use a spark plug with an unsuitable thermal range. In order for the engine to perform well, the spark plug must be clean and the electrodes must be at the right distance.

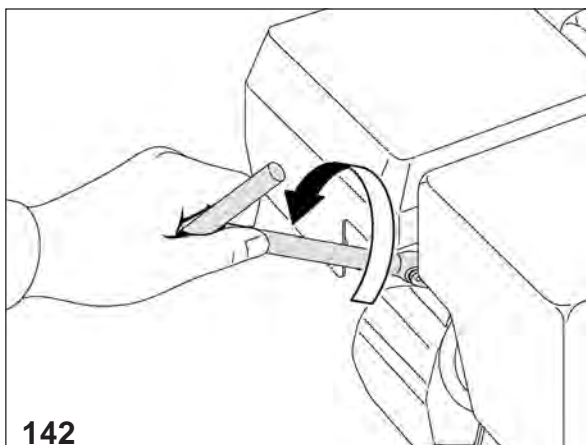

- 1 Remove the cap from the spark plug and use a spark plug key of the right size to remove the spark plug (Fig. 142).

**WARNING**

If the engine has been running, the silencer will be very hot. Take care not to get burnt.

- 2 Inspect the spark plug to check that it is not worn and that the insulator is not chipped or damaged. If this is the case, the spark plug must be replaced. Finally clean the spark plug with a steel brush.

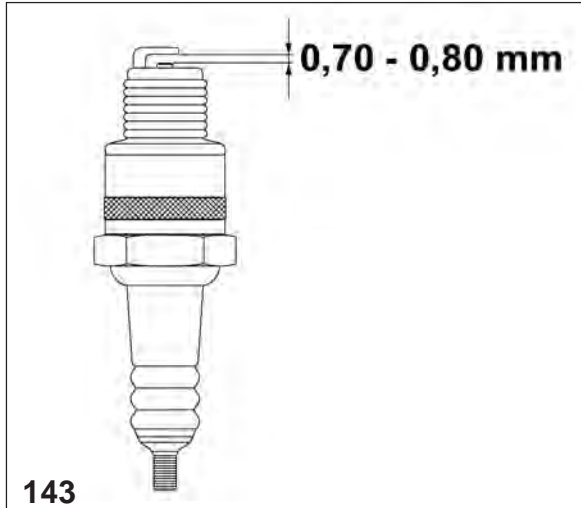

- 3 Measure the distance between the spark plug electrodes using a thickness gauge, and correct it if necessary by bending the upper electrode.

The distance must be (Fig. 143): 0.70 - 0.80 mm.

- 4 Check that the spark plug washer is in good condition. Screw in the spark plug by hand to avoid damaging the thread.

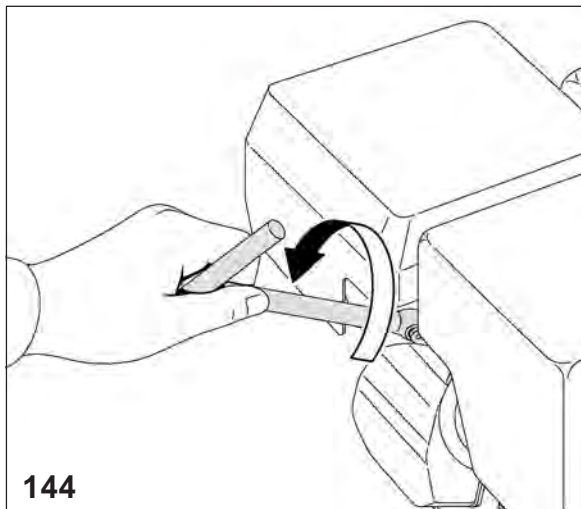

- 5 Once the spark plug rests on the base, tighten it with a key for spark plugs so that it squeezes the washer (Fig. 144).

NOTE:

When a new spark plug is fitted, tighten it by 1/2 a turn once it has been positioned so that it squeezes the washer. When a used spark plug is fitted again, tighten it by 1/8 – 1/4 of a turn until it has been positioned so that it squeezes the washer

WARNING

The spark plug must always be tightly secured. If the spark plug is not tightened sufficiently, it may overheat and damage the engine.

Minimum carburettor regulation (only petrol engines)**11.11.6**

Start up the engine and allow it to reach normal operating temperature.

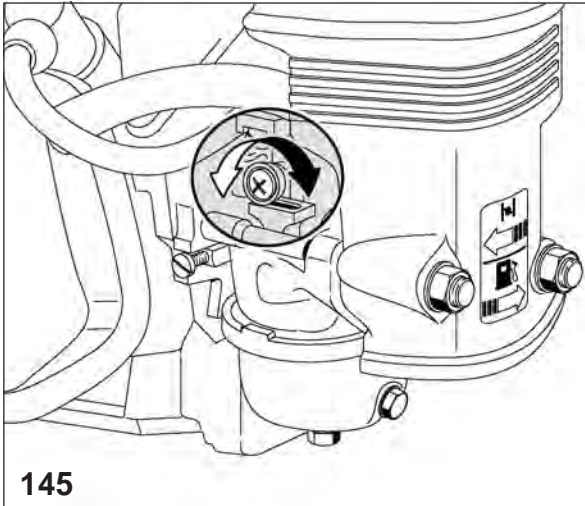

Use the accelerator setscrew (Fig. 145) with the engine running at a minimum to achieve the standard minimum speed that is 1400÷150 r.p.m.

Fuel filter**11.11.7**

The fuel filter must be cleaned according to the intervals described (see Maintenance table); a regular operating performance from the engine depends on this.

To carry out this operation, proceed as follows:

- have a container suitable for holding the fuel nearby, of a sufficient capacity to contain the quantity of fuel;

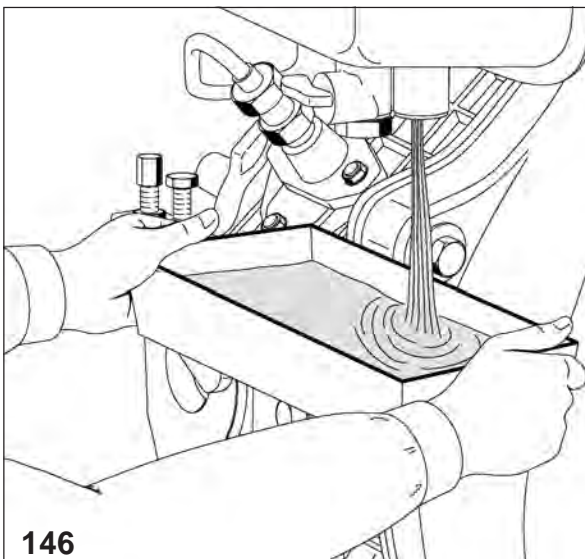

- empty the fuel from the tank by unscrewing the discharge cap (Fig. 146).

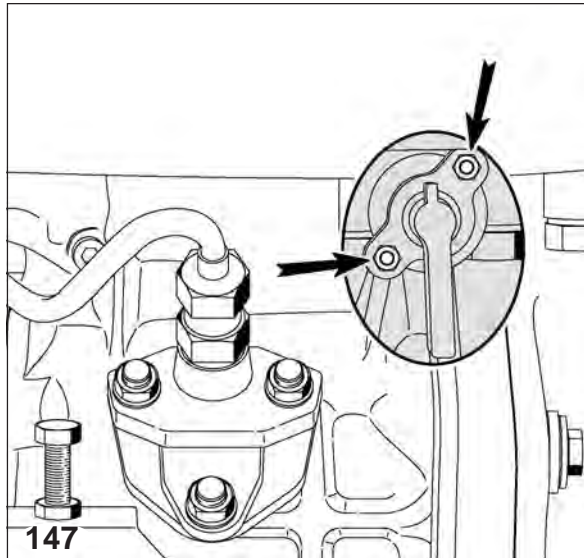

- Unscrew the carburettor cock clamp screws and remove the filter (Fig. 147).

- Wash the filter with diesel and blow compressed air into it (if necessary replace it).
- Replace the filter, screw up the fuel cock and finally screw up the discharge cap once again.

11.11.8 Battery 12 Volt (not supplied by Aerotecnica Coltri)

CAUTION

- 
- The battery electrolyte contains sulphuric acid; therefore, it is necessary to protect the eyes, skin and clothes. In the event of accidental contact, wash thoroughly with water and seek medical advice immediately, especially if the eyes are the affected area.
 - The batteries emit hydrogen, a gas that can be highly explosive. Do not smoke and do not allow naked flames or sparks to come into contact with the battery, especially during the filling operation.

At each start up (daily), check the level of the electrolyte in the battery and the condition of the same.

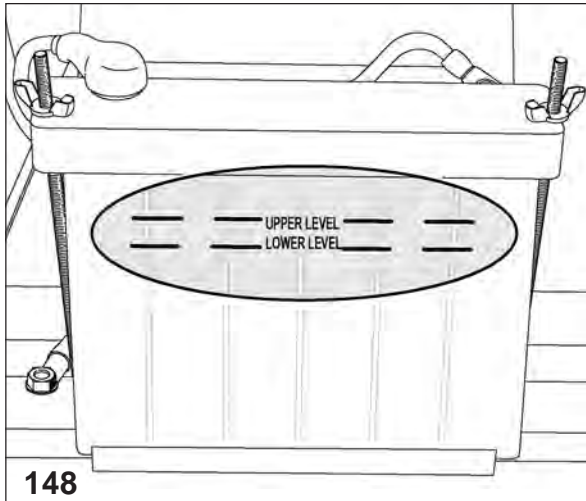

If necessary top up (Fig. 148). If there are any signs of damage, replace the battery.

CAUTION

- Before the recharge, disconnect the same from the electric system otherwise the diodes would be damaged by the high voltage.
- Reconnect the positive (+) and the negative pole (-) of the battery according to the indications given on the battery itself. If the poles are inverted, the rectifier or the battery would be damaged.
- Before proceeding with the recharging, remove the caps from each part.
- Recharge the battery in a well-ventilated place.
- Do not proceed with the recharging if the temperature of the electrolyte exceeds 45 °C (127 °F).





11.12 Maintenance operations

Use the following pages to note the routine and additional maintenance operations carried out on the machine.

If the maintenance programme is filled in accurately, it will be easier for the technician to intervene if assistance is required.

Date:

Operation carried out:

Date:

Operation carried out:

Date:

Operation carried out:

Date:

Operation carried out:

Date:

Operation carried out:

Date:

Operation carried out:

Date:

Operation carried out:

Date:

Operation carried out:

Date:

Operation carried out:

Date:

Operation carried out:

Date:

Operation carried out:

Date:

Operation carried out:

Date:

Operation carried out:

Date:

Operation carried out:

Date:

Operation carried out:



Date:

Operation carried out:

Date:

Operation carried out:

Date:

Operation carried out:

Date:

Operation carried out:

Date:

Operation carried out:

Date:

Operation carried out:

Date:

Operation carried out:

Date:

Operation carried out:

Date:

Operation carried out:

Date:

Operation carried out:

Date:

Operation carried out:

Date:

Operation carried out:

Date:

Operation carried out:

Date:

Operation carried out:

Date:

Operation carried out:

Date:

Operation carried out:

Date:

Operation carried out:

Date:

Operation carried out:



12

TROUBLESHOOTING



This chapter describes the faults that may arise during machine operation.

For each fault, the cause and the solution to be adopted are specified.

12.1 List of faults 90

12.1 List of faults

Table 1 and 2 below lists all the faults that may arise during operation and the relative solution.

Table 1

PROBLEM	CAUSE	SOLUTION
The electric motor does not start	A phase is missing.	Check the fuses.
The safety valve of the 1 st stage discharges	The 2 nd stage valves are not working.	Perform maintenance operations or replace the valves.
The safety valve of the 2 nd stage discharges	The 3 rd stage valves are not working.	Replace them.
The speed of rotation and capacity are reduced	The motor power is insufficient.	Check the motor and the power line.
	The belt slips.	Tighten the belt.
The capacity is reduced without a reduction in the speed of rotation	The valves are not working.	Contact the technical assistance service.
	The 3 rd stage piston is worn.	Contact the technical assistance service.
	The connections are loose or the gaskets leak.	Check the leaks with water and soap and eliminate them.
	The intake filter is blocked.	Replace it.
	The intake extension is bent.	Straighten it, use a semi-rigid pipe.
	The piston or compression rings are worn.	Contact the technical assistance service.
Smell of oil in the air	The filter cartridge is worn.	Replace it.
	The compression rings are worn.	Contact the technical assistance service.
The compressor overheats	Wrong direction of rotation.	Check the direction of rotation by inverting the two phases in the plug.
	The cooling pipes are dirty.	Contact the technical assistance service.
	The valves are not completely closed (causing an overload of another stage).	Contact the technical assistance service.



Table 2

MODELS WITH AN INTERNAL COMBUSTION ENGINE		
PROBLEM	CAUSE	SOLUTION
When the pulley starting is used, the engine does not start.	The engine switch is on OFF.	Move the switch to ON.
	The oil in the engine is below the minimum level.	Top the oil up to the level.
	The fuel cock is closed.	Open the cock.
	There is no fuel.	Add fuel.
	The fuel does not reach the carburettor.	Check by loosening the carburettor discharge screw with the fuel cock open.
	The spark plug does not produce any sparks.	
		Replace the spark plug.
When the electric starting is used, the engine does not start.	The battery leads are disconnected or corroded.	Check the connection of the leads and their condition.
	The battery is flat.	Recharge the battery.
	The spark arrester device is blocked by carbon deposits.	Clean the device.
The starter motor turns but the engine does not start.	See causes remedy for the pulley starting.	



13

MACHINE DIAGRAMS



This chapter provides the plans and diagrams of the systems installed on the machine.

13.1 Compression diagram 92

13.2 Electricals diagrams 93

13.1 Compression diagram

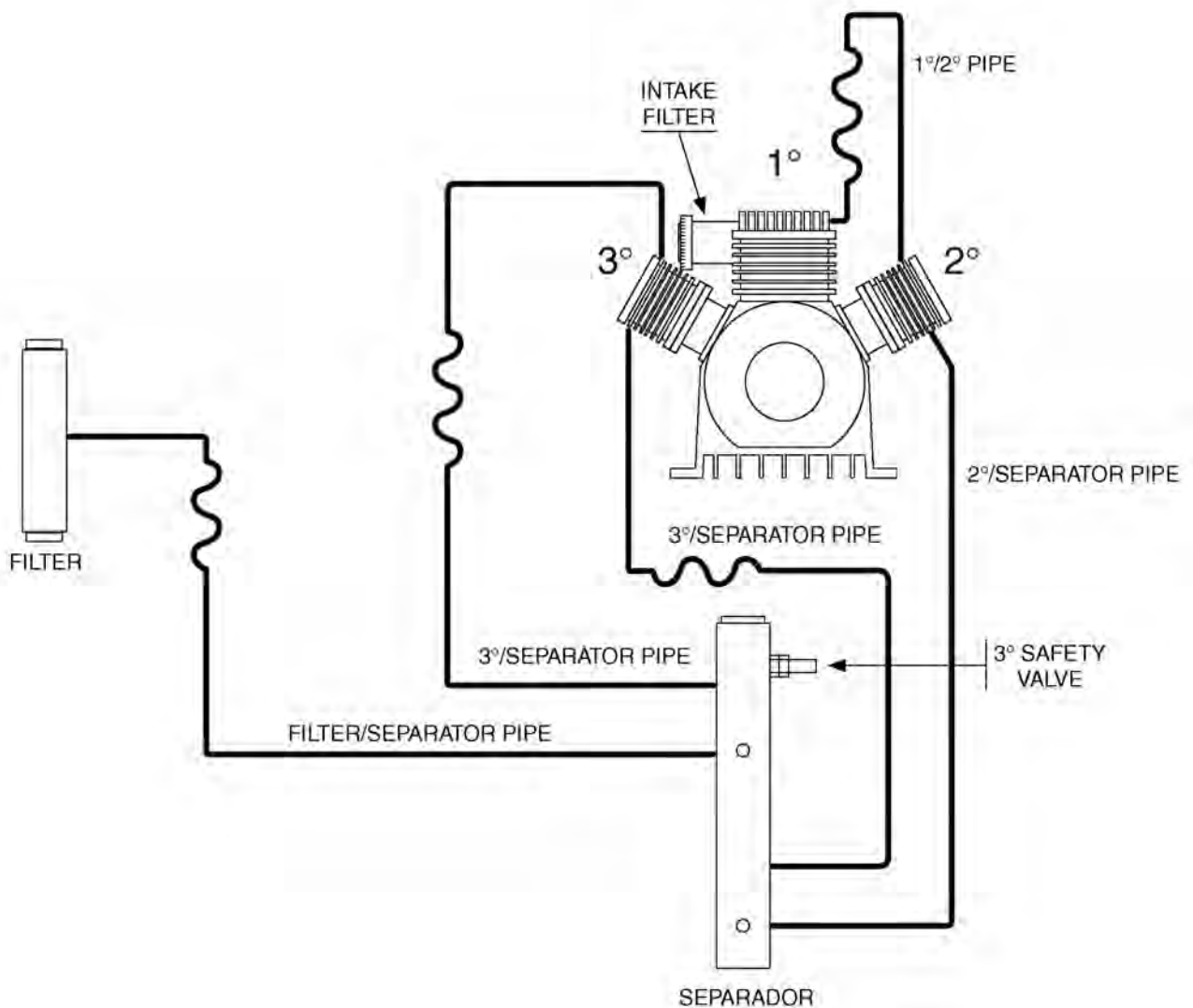

Electricals diagrams

13.2

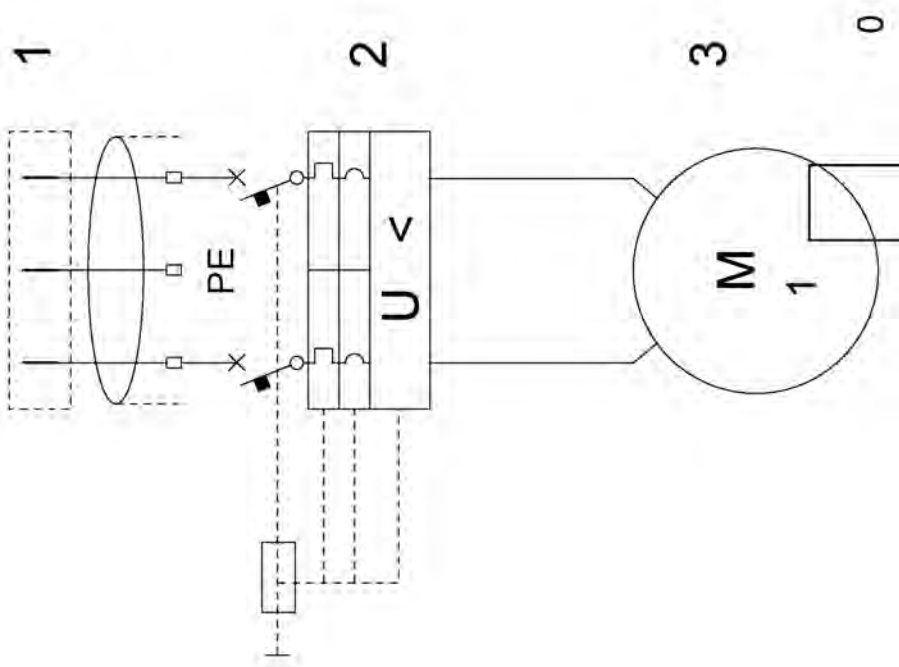
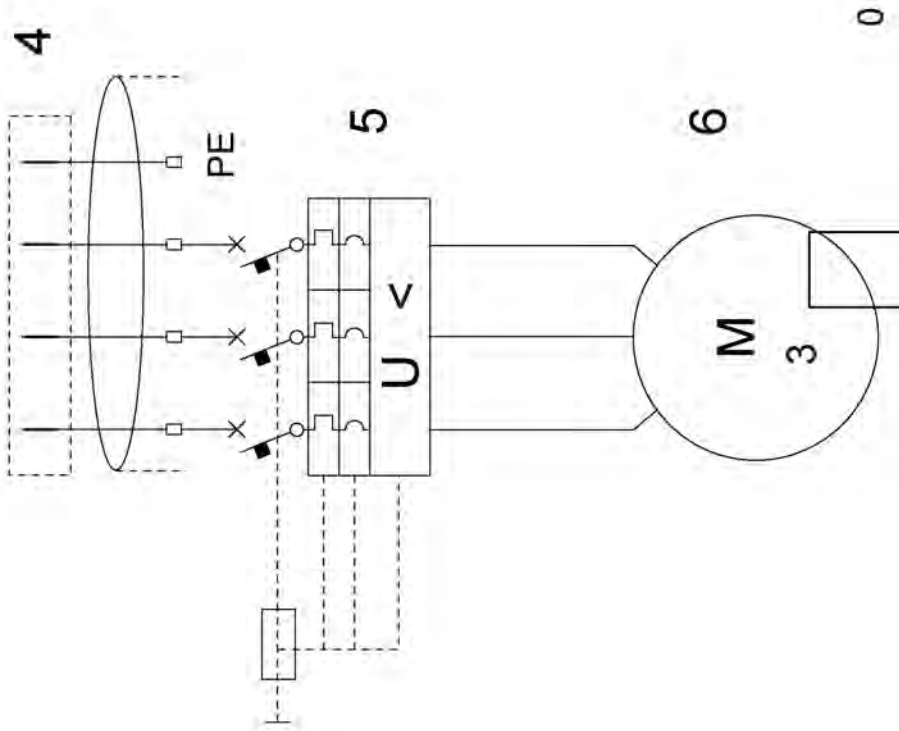

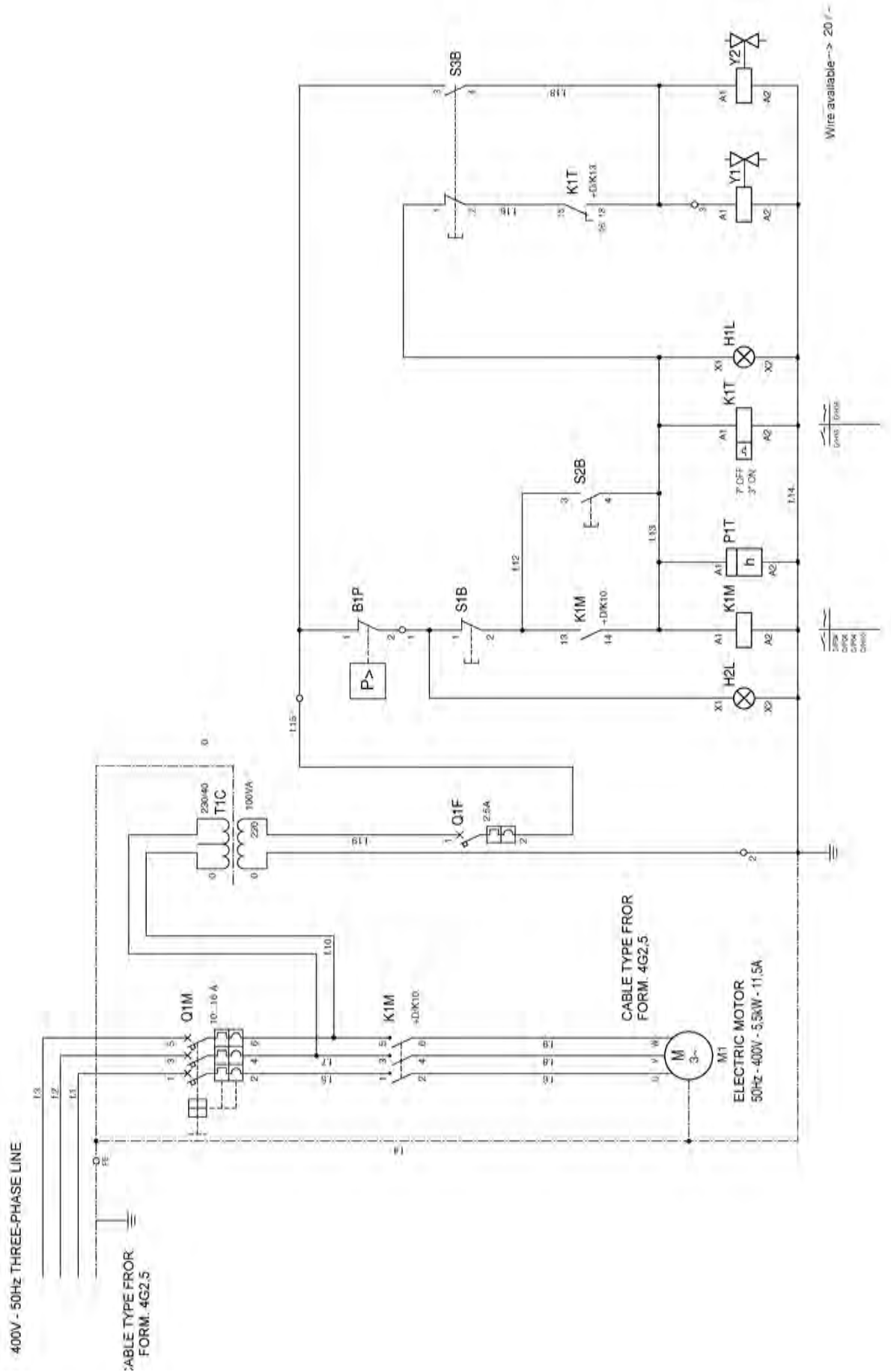



SPARE PARTS

14

14.1	<i>Exploded view of the machine parts</i>	95
	<i>Monobloc</i>	96
	<i>Pistons rod unit</i>	98
	<i>Cylinders unit</i>	100
	<i>Head unit</i>	102
	<i>Cooling pipes</i>	104
	<i>Filtering system</i>	106
	<i>Condensate trap</i>	108
	<i>MCH 13-16/ETC</i>	110
	<i>MCH 13-16/ET</i>	112
	<i>MCH 8/EM</i>	114
	<i>MCH 13-16/SH</i>	116
	<i>MCH 13-16/DY</i>	118

Exploded view of the machine parts

14.1



96

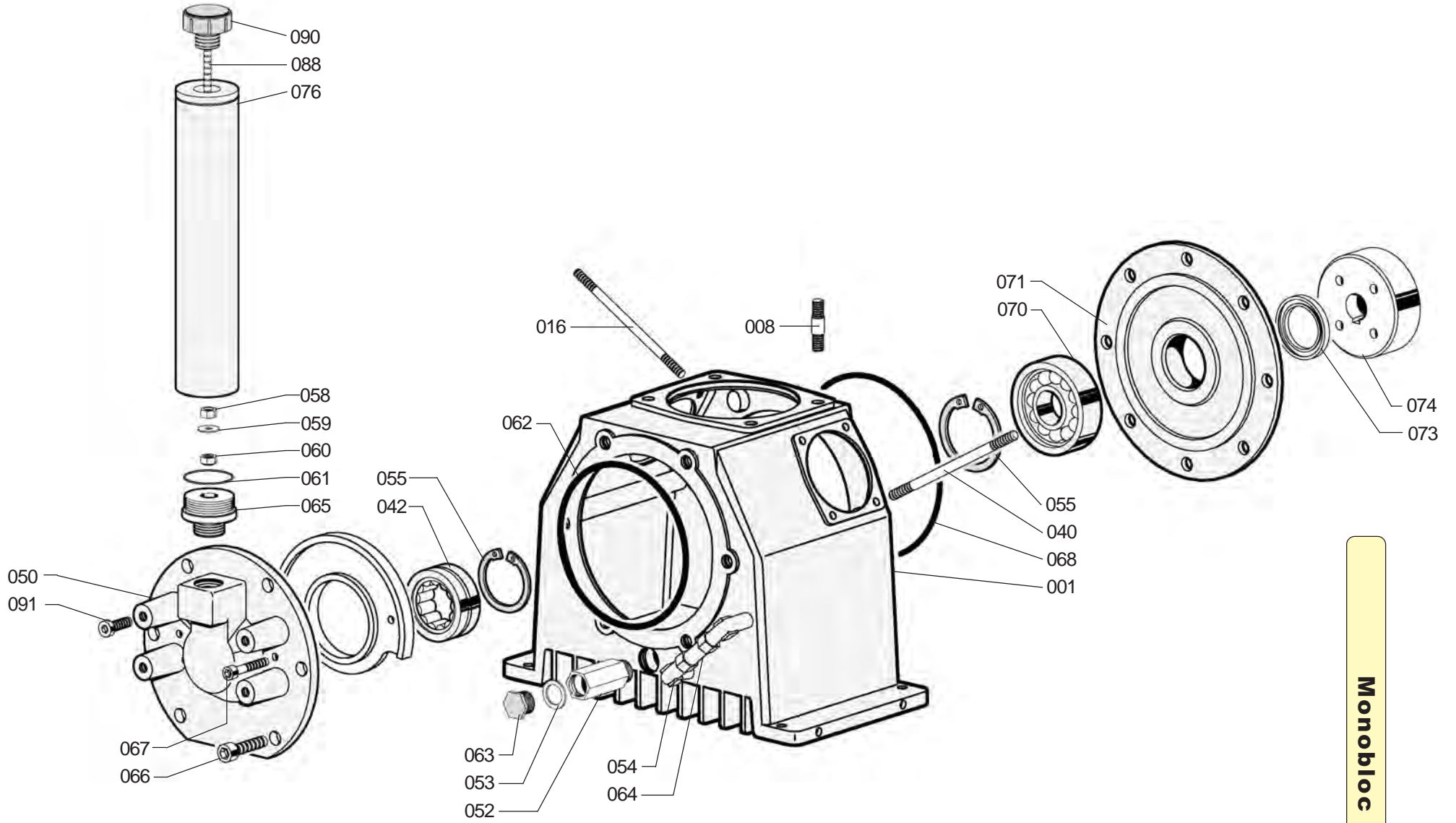

Monobloc

COLTRI S.p.A.

Spare parts



Monobloc

POS.	CODE	DESCRIPTION
001	13-00-0001	MONOBLOC
008	13-01-0008	FIRST STAGE TIE ROD
016	13-03-0016	THIRD STAGE TIE ROD
040	13-02-0040	SECOND STAGE TIE ROD
042	13-00-0042	FLANGE ROLLER BEARING NU305
050	13-00-0050	FILTER SIDE FLANGE
052	13-00-0052	OIL DISCHARGE EXTENSION
053	13-00-0053	COPPER WASHER
054	13-00-0021	CORNER 1/8 PIPE FITTING 8 mm. RILSAN
055	13-00-0055	SEEGER RETAINING RING J 62
058	13-00-0018	8 mm. NUT
059	13-00-0009	8 mm. FLAT WASHER
060	13-00-0018	8 mm. NUT
061	13-00-0061	OIL FILLING PIPE O-RING
062	13-00-0062	FLANGE O-RING
063	13-00-0063	OIL DISCHARGE CAP
064	13-00-0064	OIL LEVEL CONTROL PIPE
065	13-00-0065	OIL FILLING PIPE FITTING
066	13-00-0048	8x25 TCE SCREW
067	13-00-0067	6x35 TCE SCREW
068	13-00-0062	FLANGE O-RING
070	13-00-0070	BALL BEARING 6302
071	13-00-0071	FAN SIDE FLANGE
073	13-00-0073	OIL SPLASH GUARD 30-48-8
074	13-00-0074	FAN-HOLDING HUB
076	13-00-0076	OIL FILLING PIPE WITH UPPER FLANGE
088	13-00-0088	8 mm. THREADED ROD
090	13-00-0090	OIL FILLING CAP
091	13-00-0048	8x25 TCE SCREW



88

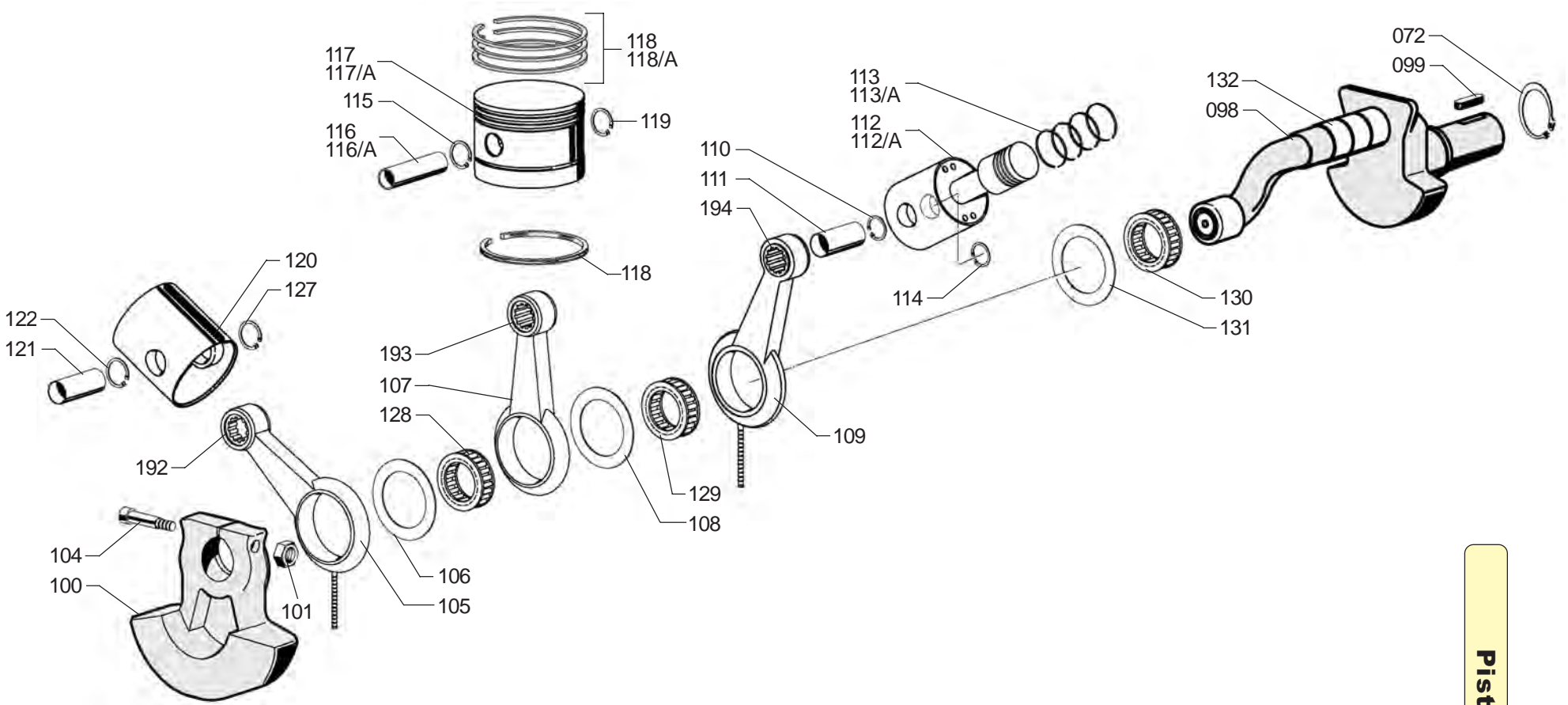

Pistons rod unit

Spare parts

COLTIRI S.p.A.



Pistons rod unit

POS.	CODE	DESCRIPTION
072	13-00-0072	SEEGER RETAINING RING A 30
098	13-00-0098	GOOSENECK
099	13-00-0099	KEY
100	13-00-0100	COUNTERWEIGHT
101	13-00-0101	8 mm. SELF-LOCKING NUT
104	13-00-0104	8x65 TCE SCREW
105	13-00-0105	THIRD STAGE CONNECTING ROD
106	13-00-0106	SPACER
107	13-01-0107	FIRST STAGE CONNECTING ROD
108	13-00-0106	SPACER
109	13-00-0105	SECOND STAGE CONNECTING ROD
110	13-00-0110	SEEGER RETAINING RING
111	13-02-0111	2nd STAGE PIN
112	13-02-0112	SECOND STAGE 36 mm. PISTON
112/A	16-02-0112	SECOND STAGE 38 mm. PISTON
113	13-02-0113	SET OF 2nd STAGE 36 mm. PISTON RINGS
113/A	16-02-0113	SET OF 2nd STAGE 38 mm. PISTON RINGS
114	13-00-0110	SEEGER RETAINING RING
115	13-00-0110	SEEGER RETAINING RING
116	13-01-0116	FIRST STAGE 88 mm. PIN
116/A	16-01-0116	FIRST STAGE 95 mm. PIN
117	13-01-0117	FIRST STAGE 88 mm. PISTON
117/A	16-01-0117	FIRST STAGE 95 mm. PISTON
118	13-01-0118	SET OF 1st STAGE 88 mm. PISTON RINGS
118/A	16-01-0118	SET OF 1st STAGE 95 mm. PISTON RINGS
119	13-00-0110	SEEGER RETAINING RING
120	13-03-0120	GUIDING SLIDING BLOCK
121	13-02-0111	3rd STAGE PIN
122	13-00-0110	SEEGER RETAINING RING
127	13-00-0110	SEEGER RETAINING RING
128	13-00-0128	ROLLER CAGE
129	13-00-0128	ROLLER CAGE
130	13-00-0128	ROLLER CAGE
131	13-00-0106	SPACER
132	13-00-0132	HARDENED RING
192	13-00-0192	ROLLER CAGE
193	13-00-0192	ROLLER CAGE
194	13-00-0192	ROLLER CAGE

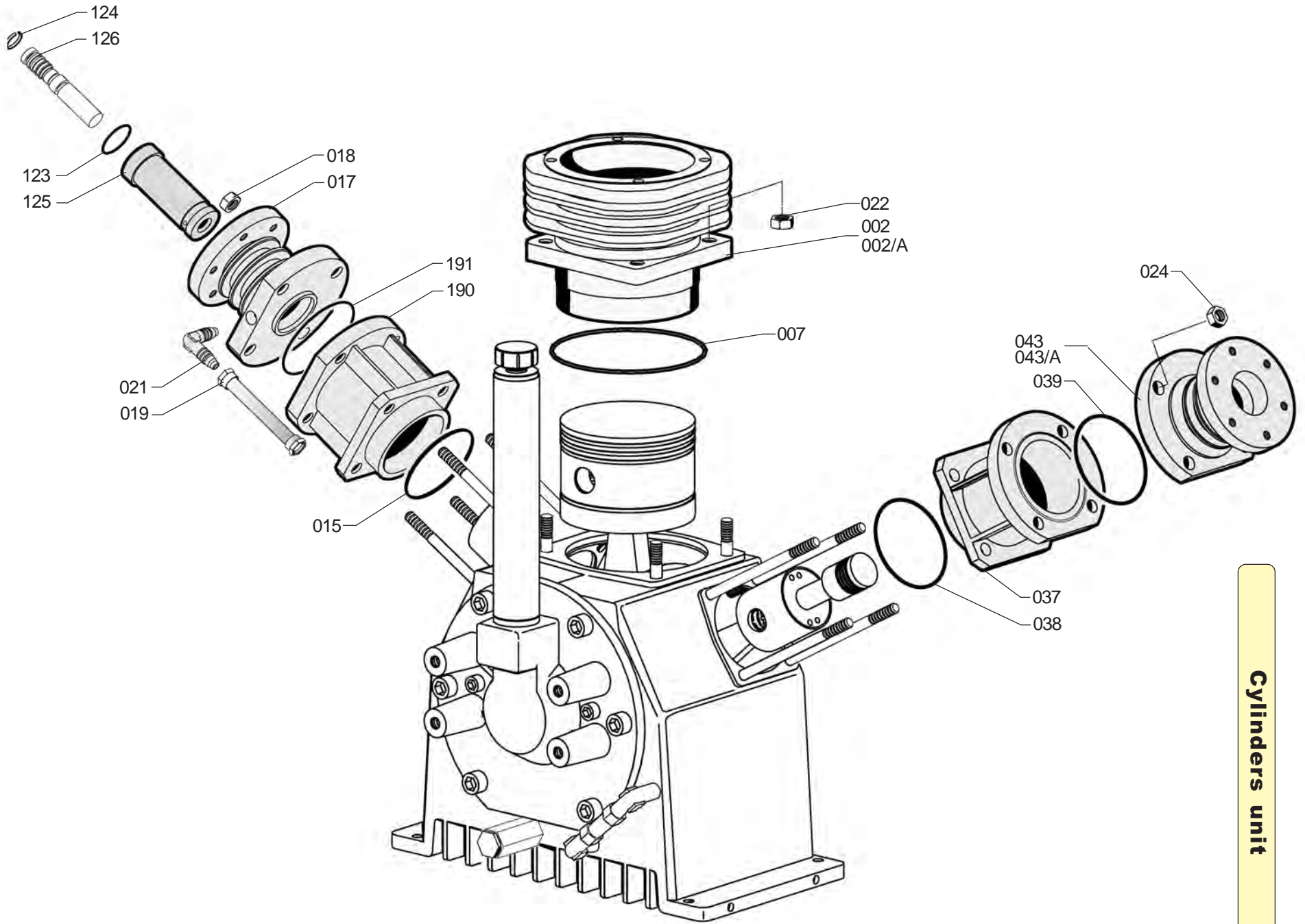

100

Cylinders unit

Spare parts

COLTRI S.p.A.



Cylinders unit

POS.	CODE	DESCRIPTION
002	13-01-0002	FIRST STAGE 88 mm. CYLINDER
002/A	16-01-0002	FIRST STAGE 95 mm. CYLINDER
007	13-01-0007	FIRST STAGE CYLINDER O-RING
015	13-00-0015	THIRD STAGE CYLINDER O-RING
017	13-02-0017	THIRD STAGE GUIDING CYLINDER
018	13-00-0018	8 mm. BOLT
019	13-00-0019	LUBRICATION INDICATOR PIPE
021	13-00-0021	CORNER 1/8 PIPE FITTING 8 mm. RILSAN
022	13-00-0018	8 mm. NUT
024	13-00-0018	8 mm. NUT
037	13-02-0037	SECOND STAGE 60 mm. GUIDING CYLINDER
038	13-00-0015	GUIDING CYLINDER O-RING
039	13-00-0039	SECOND STAGE CYLINDER O-RING
043	13-02-0043	SECOND STAGE 36 mm. CYLINDER
043/A	16-02-0043	SECOND STAGE 38 mm. CYLINDER
123	13-03-0123	3rd STAGE VITON O-RING
124	13-03-0124	SET OF 3rd STAGE PISTON RINGS
125	13-03-0125	14 mm. THIRD STAGE CYLINDER
126	13-03-0126	14 mm. THIRD STAGE PISTON
190	13-03-0190	THIRD STAGE 60 mm GUIDING CYLINDER
191	13-00-0039	THIRD STAGE GUIDING CYLINDER O-RING

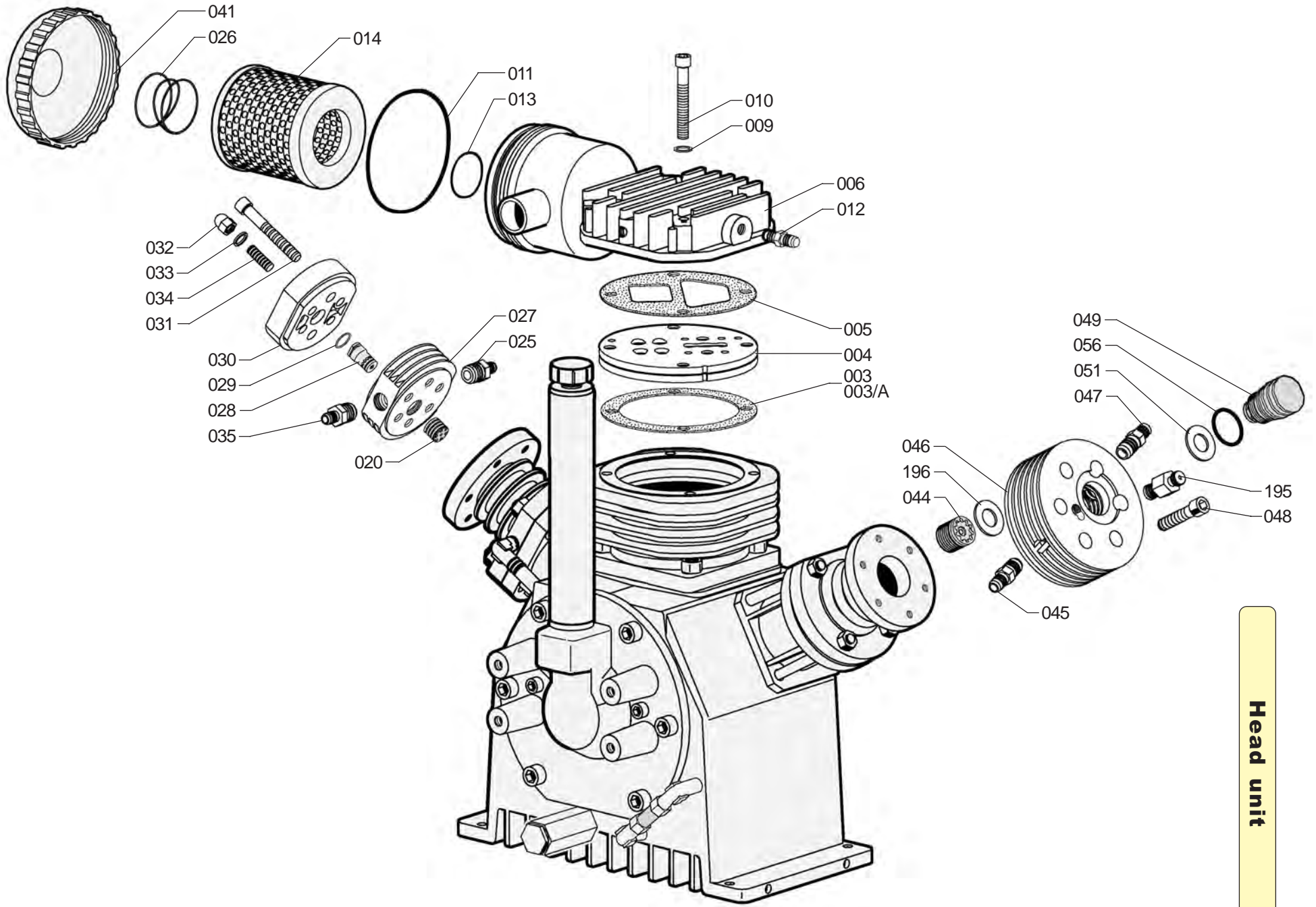

Head unit



Head unit

POS.	CODE	DESCRIPTION
003	13-01-0003	FIRST STAGE 88 mm. GASKET
003/A	16-01-0003	FIRST STAGE 95 mm. GASKET
004	13-01-0004	FIRST STAGE HEAD WITH VALVES
005	13-01-0005	FIRST STAGE GASKET
006	13-01-0006	FIRST STAGE HEAD COVER
009	13-00-0009	8 mm. FLAT WASHER
010	13-00-0010	SCREW 8x55 TCE
011	13-01-0011	INTAKE FILTER COVER O-RING
012	13-00-0012	STRAIGHT 1/4 PIPE FITTING 10 mm
013	13-01-0013	INTAKE FILTER O-RING
014	SC000370	LUBRICATION INDICATOR PIPE
020	13-03-0020	THIRD STAGE INTAKE VALVE
025	13-00-0025	STRAIGHT 1/4 - PIPE FITTING 6 mm.
026	13-01-0026	INTAKE FILTER SPRING
027	13-03-0027	THIRD STAGE HEAD
028	13-03-0028	THIRD STAGE EXHAUST VALVE
029	13-03-0029	VITON O-RING FOR THIRD STAGE EXHAUST VALVE
030	13-03-0030	3rd STAGE HEAD COVER
031	13-00-0031	8x50 TCE SCREW
032	13-00-0032	STAINLESS STEEL 8 mm. CAP NUT
033	13-03-0033	8 mm. COPPER WASHER
034	13-03-0034	8x25 STAINLESS STEEL DOWEL
035	13-00-0035	STRAIGHT 1/4 PIPE FITTING 8 mm.
041	13-01-0041	INTAKE FILTER COVER
044	13-02-0044	SECOND STAGE INTAKE VALVE
045	13-02-0045	LONG STRAIGHT 1/4 PIPE FITTING 10
046	13-02-0046	SECOND STAGE HEAD
047	13-02-0047	LONG STRAIGHT 1/4 PIPE FITTING 10
048	13-00-0048	8x25 TCE SCREW
049	13-02-0049	SECOND STAGE EXHAUST VALVE
051	13-02-0051	SECOND STAGE COPPER GASKET
056	13-02-0056	VITON O-RING FOR 2nd STAGE VALVE
195	13-00-0195	FIRST STAGE SAFETY VALVE
196	13-02-0051	SECOND STAGE COPPER GASKET



104

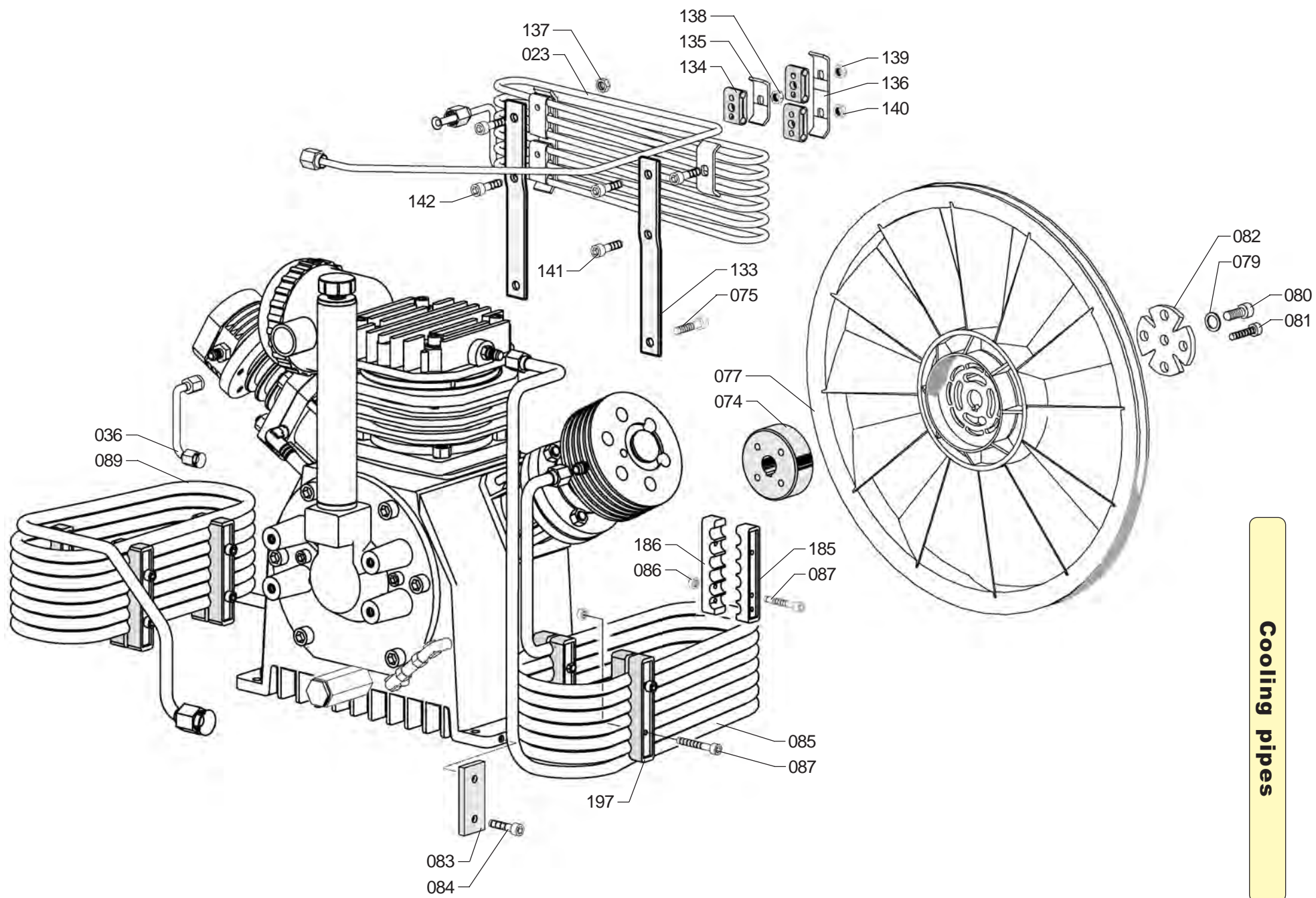

Cooling pipes

Spare parts

COLTRI S.p.A



Cooling pipes

POS.	CODE	DESCRIPTION
023	13-03-0023	6 mm. COOLING PIPE
036	13-00-0036	8 mm. PIPE
074	13-00-0074	FAN-HOLDING HUB
075	13-00-0075	8x30 TCE SCREW
077	13-00-0077	COOLING FAN
079	13-00-0079	12 mm. FLAT WASHER
080	13-00-0080	12x35 TCE SCREW
081	13-00-0081	10x40 TCE SCREW
082	13-00-0082	FAN FLANGE
083	13-00-0083	GALVANIZED PIPE-HOLDING BRACKET
084	13-00-0084	6x15 TCE SCREW
085	13-00-0085	1st-2nd STAGE 10 mm. COOLING PIPE
086	13-00-0086	6 mm. NUT
087	13-00-0087	6x30 TCE SCREW
089	13-00-0089	10 mm. 2nd-3rd STAGE COOLING PIPE
133	13-00-0133	6 mm. PIPE-HOLDING BRACKET
134	13-00-0134	VIBRATION-DAMPING PIPE-HOLDING RUBBER WASHER
135	13-00-0135	SINGLE 6 mm. PIPE-HOLDING BRACKET
136	13-00-0136	DOUBLE 6 mm. PIPE-HOLDING BRACKET
137	13-00-0137	SELF-LOCKING 6MA NUT
138	13-00-0137	SELF-LOCKING 6MA NUT
139	13-00-0137	SELF-LOCKING 6MA NUT
140	13-00-0137	SELF-LOCKING 6MA NUT
141	13-00-0141	6x25 TCE SCREW
142	13-00-0141	6x25 TCE SCREW
186	13-00-0186	3-HOLE PIPE-HOLDING BRACKET
197	13-00-0197	2-HOLE PIPE-HOLDING BRACKET



Filtering system

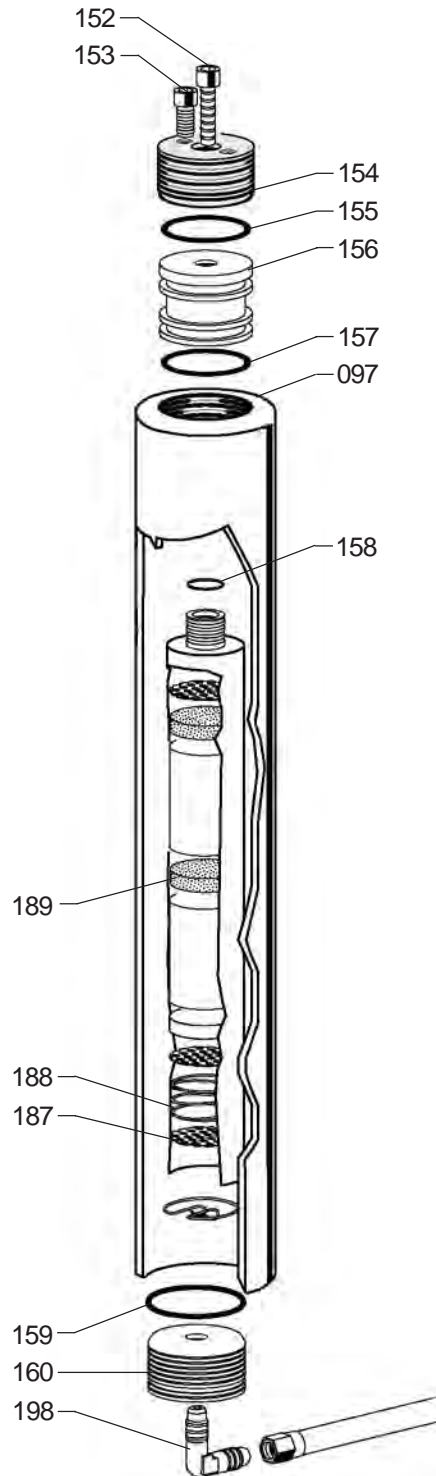

**Filtering system**

POS.	CODE	DESCRIPTION
097	13-00-0097	CLEANER FILTER
152	13-00-0152	VITE 8x30 TCE
153	13-00-0153	VITE 8x12 TCE
154	13-00-0154	UPPER FILTER CAP
155	13-00-0155	FILTER CAP O-RING
156	13-00-0156	INTERNAL FILTER CAP
157	13-00-0155	FILTER CAP O-RING
158	13-00-0158	FILTER CARTRIDGE O-RING
159	13-00-0155	FILTER CAP O-RING
160	13-00-0160	LOWER FILTER CAP
187	13-00-0187	MESH DISK DIAM. 39 mm.
188	13-00-0188	FILTER CARTRIDGE INTERNAL SPRING
189	13-00-0189	FELT DISK DIAM. 40 mm
198	13-00-0144	CORNER 1/8 PIPE FITTING 6 mm.



Condensate trap

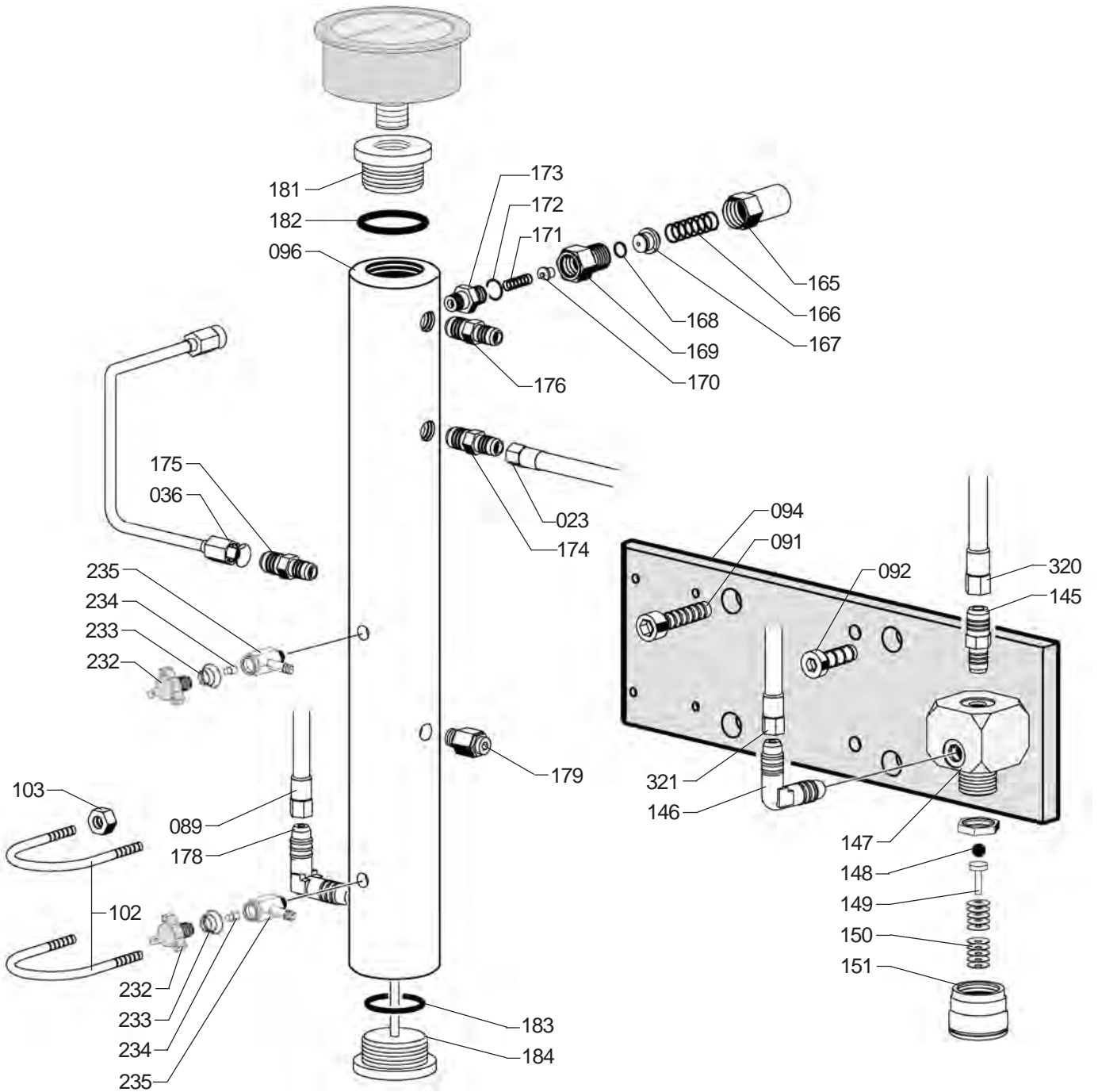



Condensate trap

POS.	CODE	DESCRIPTION
023	13-03-0023	6 mm. COOLING PIPE
036	13-00-0036	8 mm. PIPE
089	13-00-0089	10 mm. 2nd-3rd STAGE COOLING PIPE
091	13-00-0048	8x25 TCE SCREW
092	13-00-0092	LOWERED 8x20 TCE SCREW
094	13-00-0094	FILTER-HOLDING PLATE
096	13-00-0096	CONDENSATE TRAP
102	13-00-0102	TRAP-HOLDING BRACKET
103	13-00-0018	8 mm. NUT
145	13-00-0025	STRAIGHT 1/4 - PIPE FITTING 6 mm.
146	13-00-0146	CORNER 1/4 - PIPE FITTING 6 mm.
147	13-00-0147	V.M.P. BODY
148	13-00-0148	V.M.P. STEEL BALL
149	13-00-0149	SMALL V.M.P. PISTON
150	13-00-0150	SET OF BELLEVILLE WASHERS
151	13-00-0151	V.M.P. CAP
165	13-00-0165	SAFETY VALVE ADJUSTMENT COVER
166	13-00-0166	SAFETY VALVE SPRING
167	13-00-0167	SMALL SAFETY VALVE PISTON
168	13-00-0168	SMALL S.V. PISTON O-RING
169	13-00-0169	SAFETY VALVE BODY
170	13-00-0170	NYLON SAFETY VALVE SEAT
171	13-00-0171	SAFETY VALVE SEAT SPRING
172	13-00-0172	SAFETY VALVE O-RING
173	13-00-0173	SAFETY VALVE CONNECTOR
174	13-00-0174	STRAIGHT 1/8 PIPE FITTING 6
175	13-00-0174	STRAIGHT 1/8 PIPE FITTING 6
176	13-00-0174	STRAIGHT 1/8 PIPE FITTING 6
178	13-00-0178	CORNER 1/4 - PIPE FITTING 10 mm.
179	13-03-0179	SECOND STAGE SAFETY VALVE
181	13-00-0181	UPPER TRAP/FILTER TRAP CAP
182	13-00-0182	UPPER TRAP CAP O-RING
183	13-00-0182	TRAP CAP O-RING
184	13-00-0184	LOWER TRAP CAP
198	13-00-0144	CORNER 1/8 - PIPE FITTING 6 mm.
232	13-00-0164	CONDENSATE DISCHARGE HANDWHEEL
233	13-00-0163	CONDENSATE DISCHARGE SPRING
234	13-00-0162	NYLON CONDENSATE DISCHARGE
235	13-00-0161	CONDENSATE DISCHARGE TAP CASING
320	13-04-0320	HP 6 mm. PIPE
321	13-04-0321	HP 800 mm. PIPE



MCH 13-16/ETC

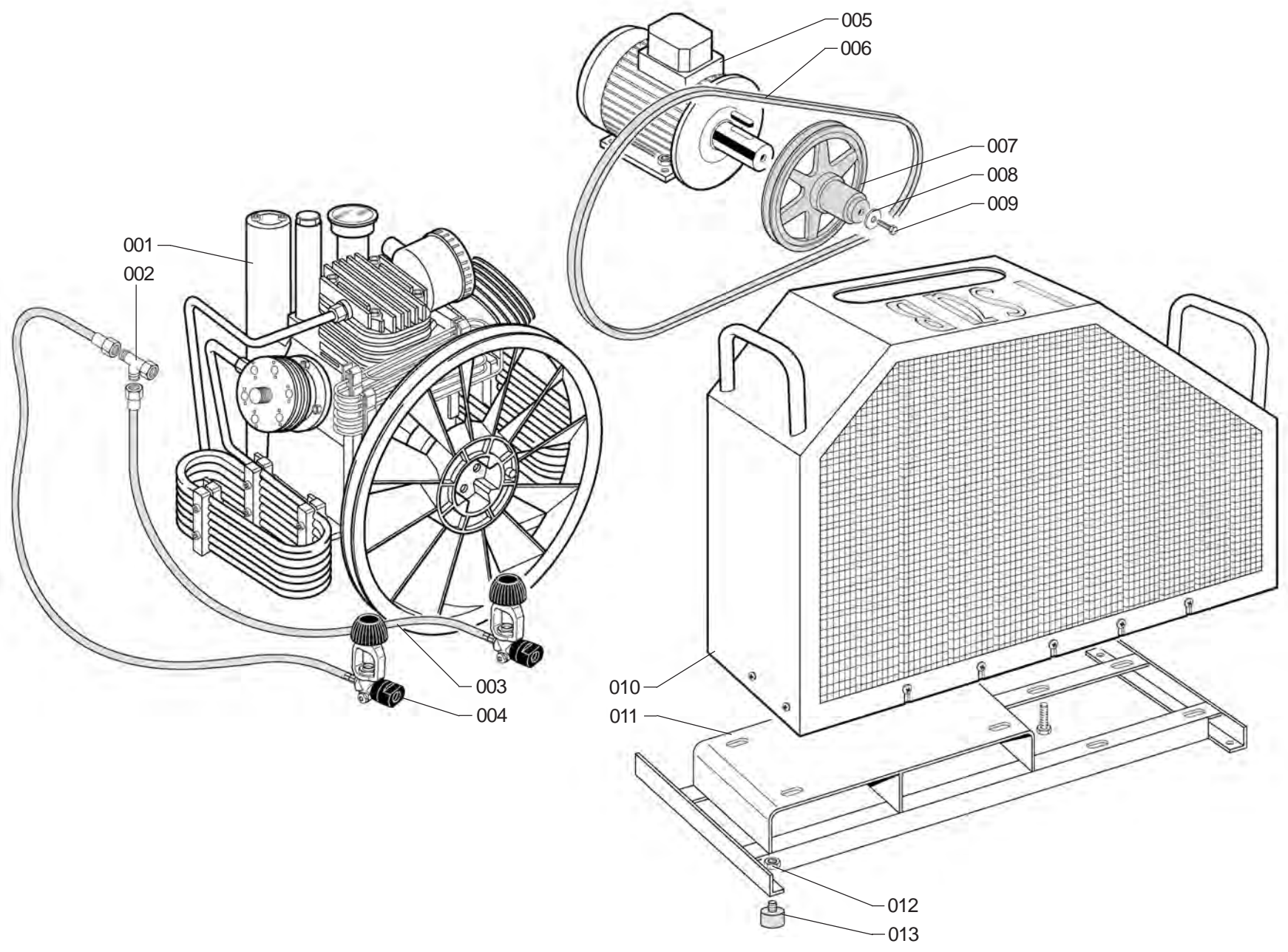

**MCH 13-16/ETC**

POS.	CODE	DESCRIPTION
001		PUMP UNIT
002		CORNER 1/8 A "T"
003		STRAIGHT 1/8 - PIPE FITTING 6
004		BC INTERNAL COCK
005		ELECTRIC THREE-PHASE ENGINE
006		DRIVING BELT A71
007		PULLEY
008		WASHER
009		TE SCREW
010		STANDARD MCH 13-16/ETC COVER
011		BASE
012		NUT
013		VIBRATION-DAMPING SUPPORT



MCH 13-16/ET

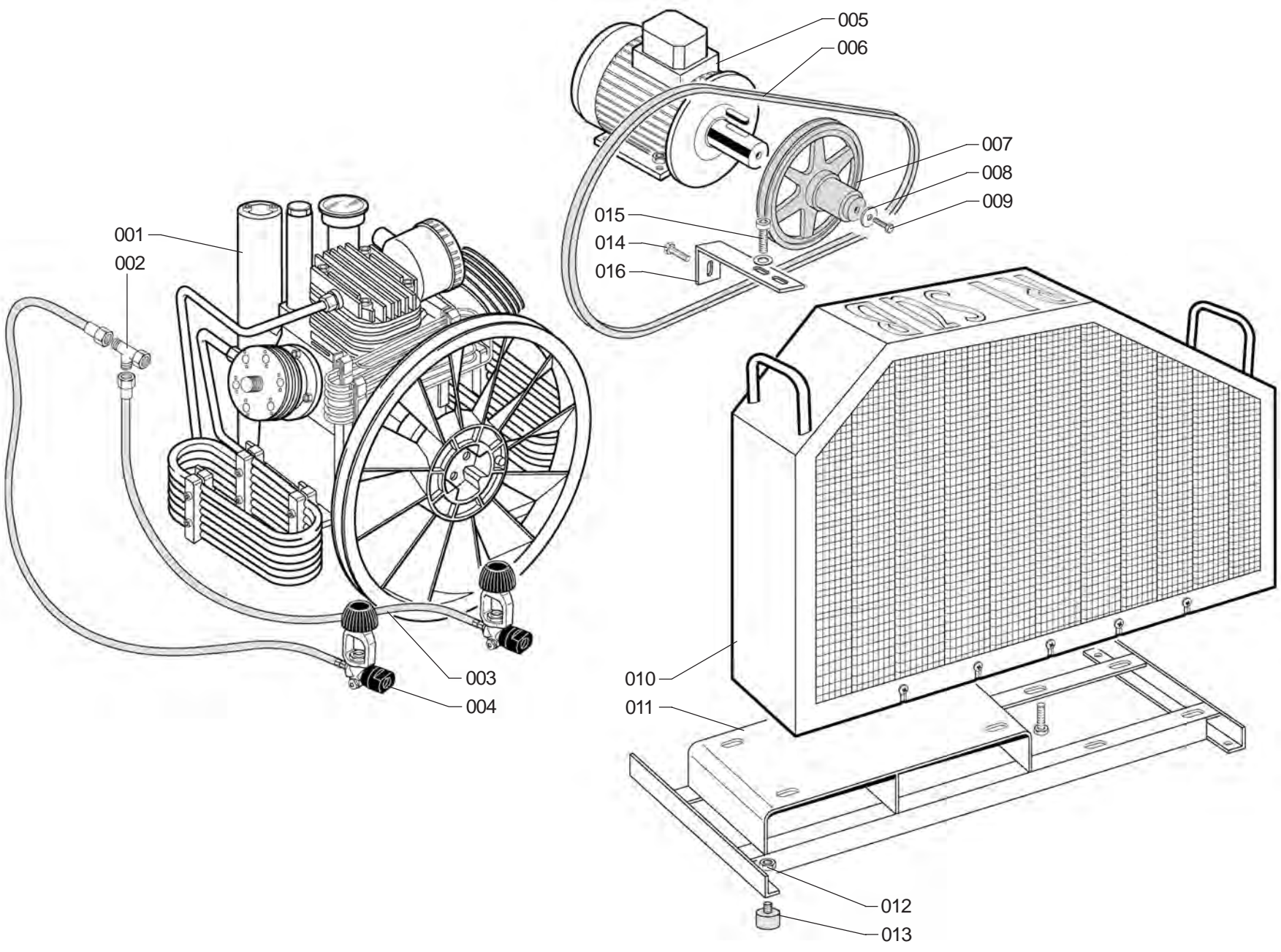

**MCH 13-16/ET**

POS.	CODE	DESCRIPTION
001		PUMP UNIT
002		CORNER 1/8 A "T"
003		STRAIGHT 1/8 - PIPE FITTING 6
004		BC INTERNAL COCK
005		ELECTRIC THREE-PHASE ENGINE
006		DRIVING BELT A71
007		PULLEY
008		WASHER
009		TE SCREW
010		STANDARD MCH 13-16/ET COVER
011		BASE
012		NUT
013		VIBRATION-DAMPING SUPPORT
014		TE SCREW
015		TCEI SCREW
016		BRACKET

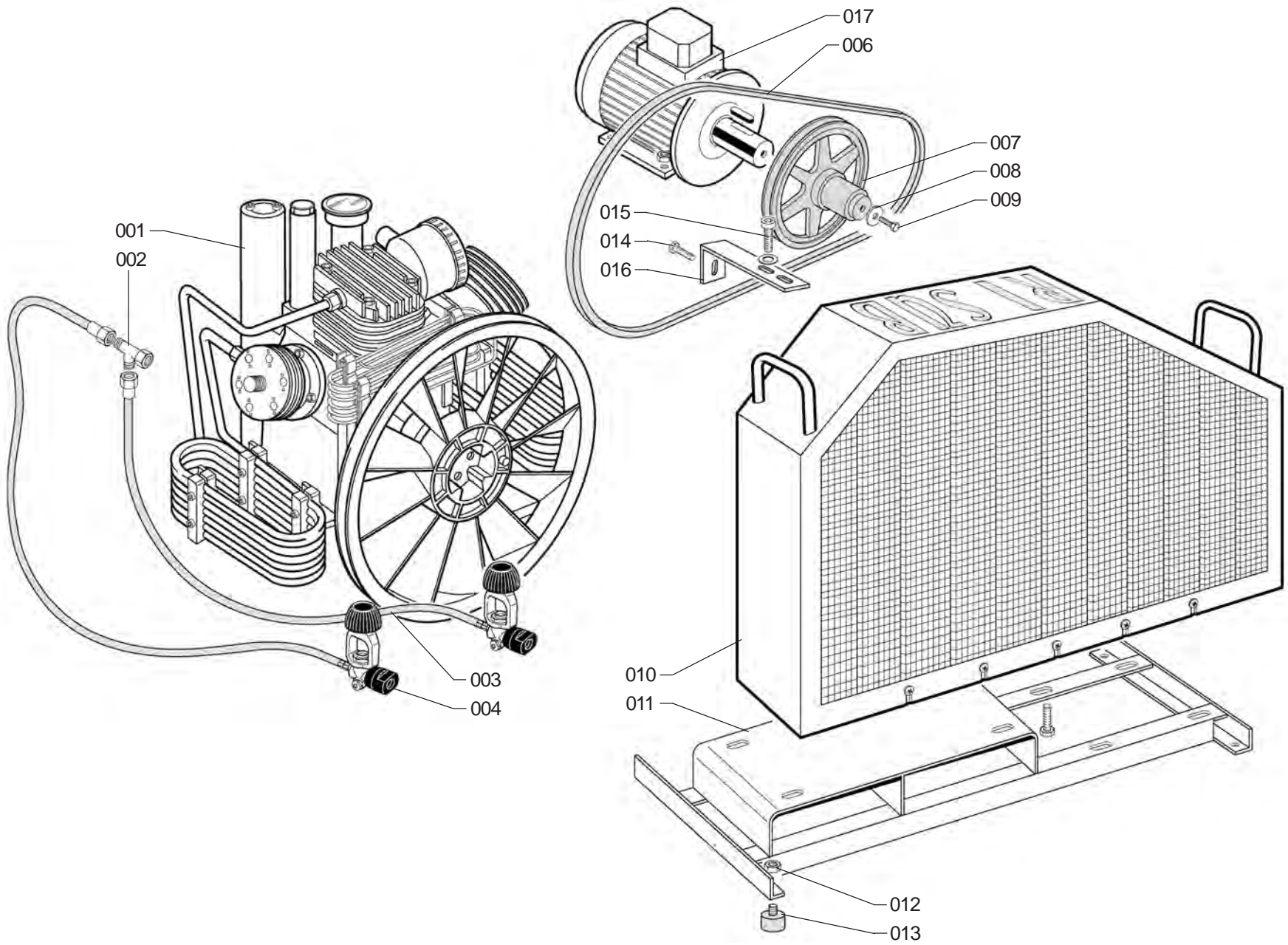

MCH 8/EM

**MCH 8/EM**

POS.	CODE	DESCRIPTION
001		PUMP UNIT
002		CORNER 1/8 A "T"
003		STRAIGHT 1/8 - PIPE FITTING 6
004		BC INTERNAL COCK
006		DRIVING BELT A71
007		PULLEY
008		WASHER
009		TE SCREW
010		STANDARD MCH 8/EM COVER
011		BASE
012		NUT
013		VIBRATION-DAMPING SUPPORT
014		TE SCREW
015		TCEI SCREW
016		BRACKET
017		ELECTRIC SINGLE PHASE ENGINE



MCH 13-16/SH

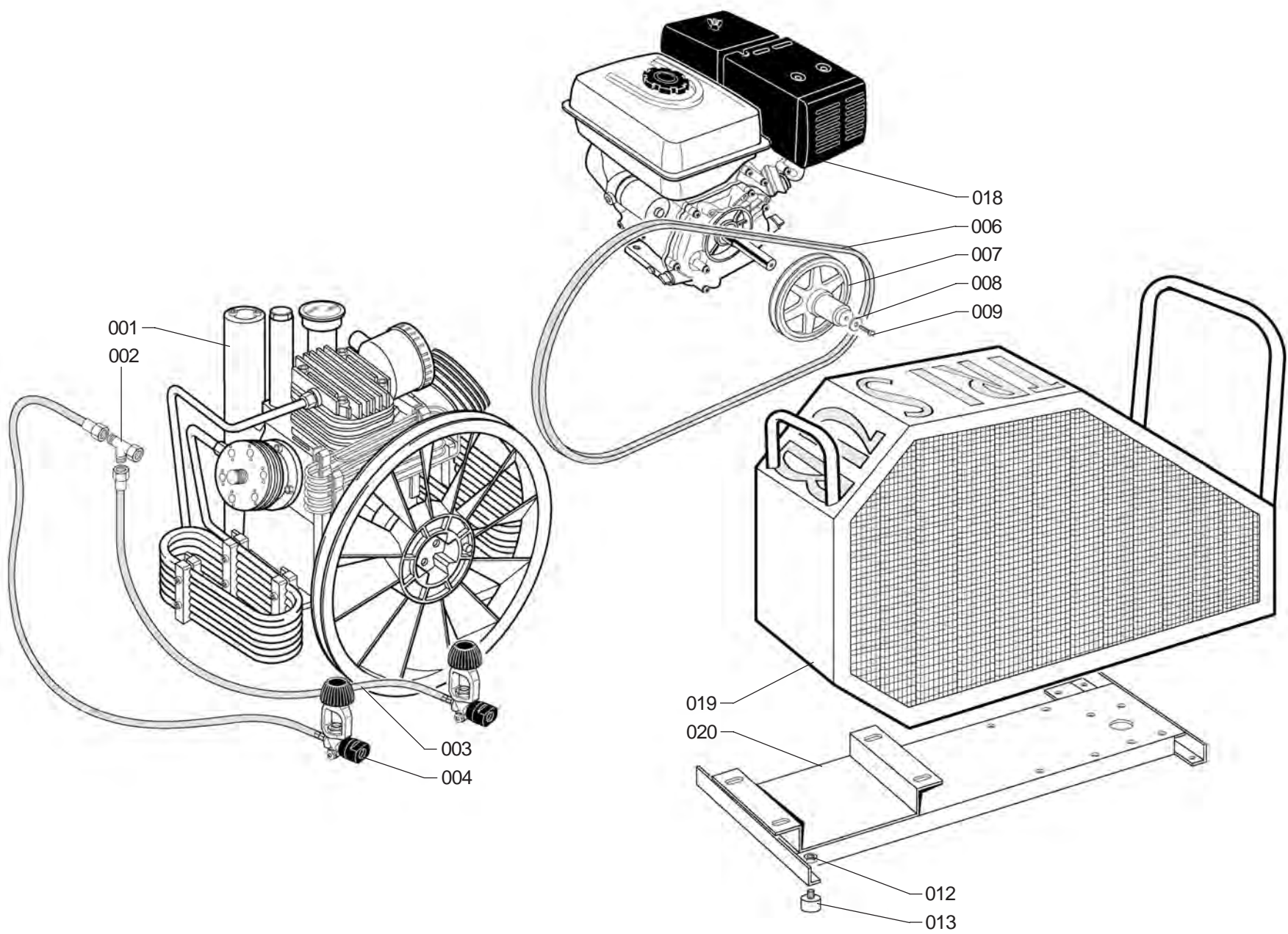

**MCH 13-16/SH**

POS.	CODE	DESCRIPTION
001		PUMP UNIT
002		CORNER 1/8 A "T"
003		STRAIGHT 1/8 - PIPE FITTING 6
004		BC INTERNAL COCK
006		DRIVING BELT A71
007		PULLEY
008		WASHER
009		TE SCREW
012		NUT
013		VIBRATION-DAMPING SUPPORT
014		TE SCREW
015		TCEI SCREW
016		BRACKET
018		PETROL HONDA ENGINE
019		STANDARD MCH 13-16/SH COVER
020		BASE



MCH 13-16/DY

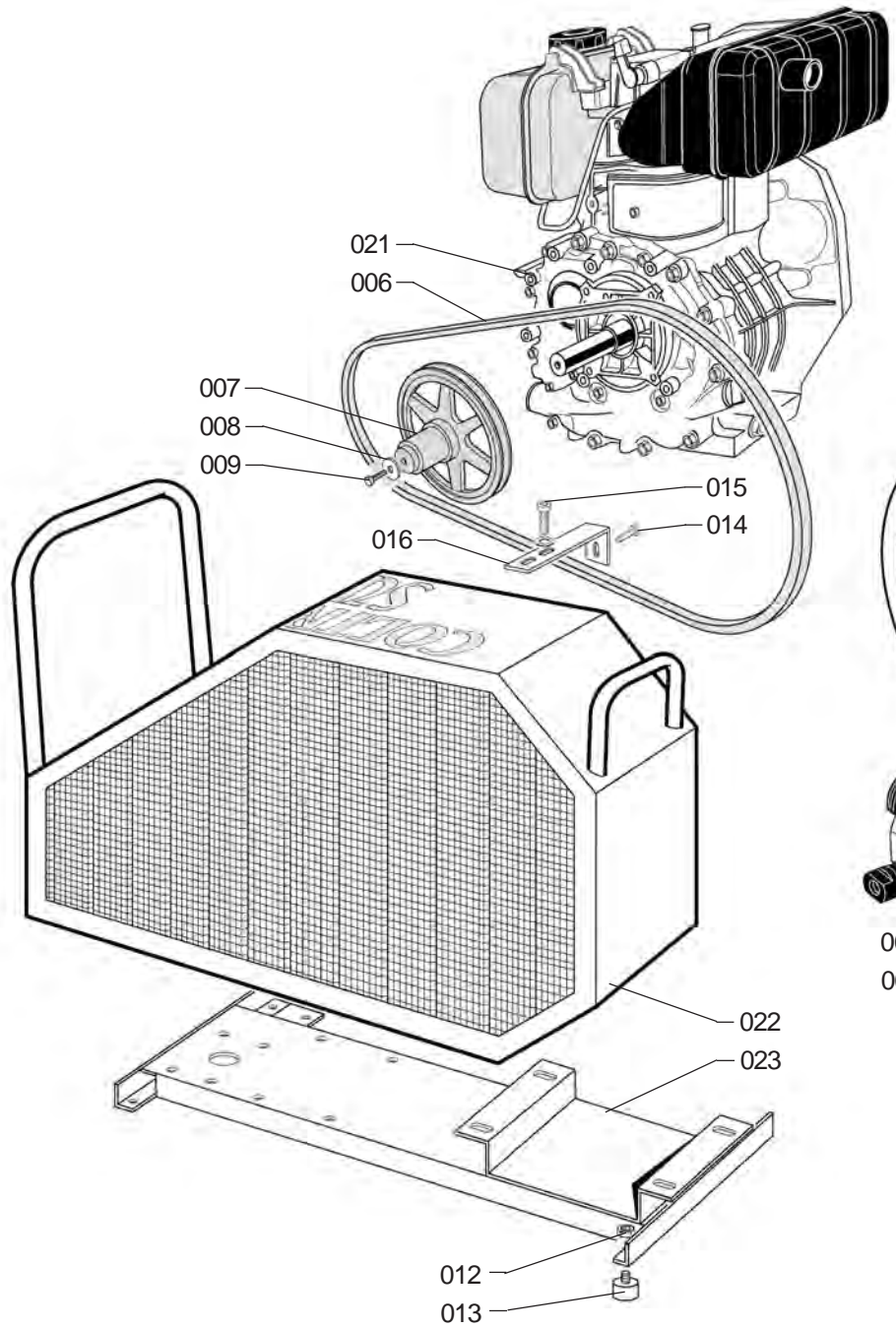
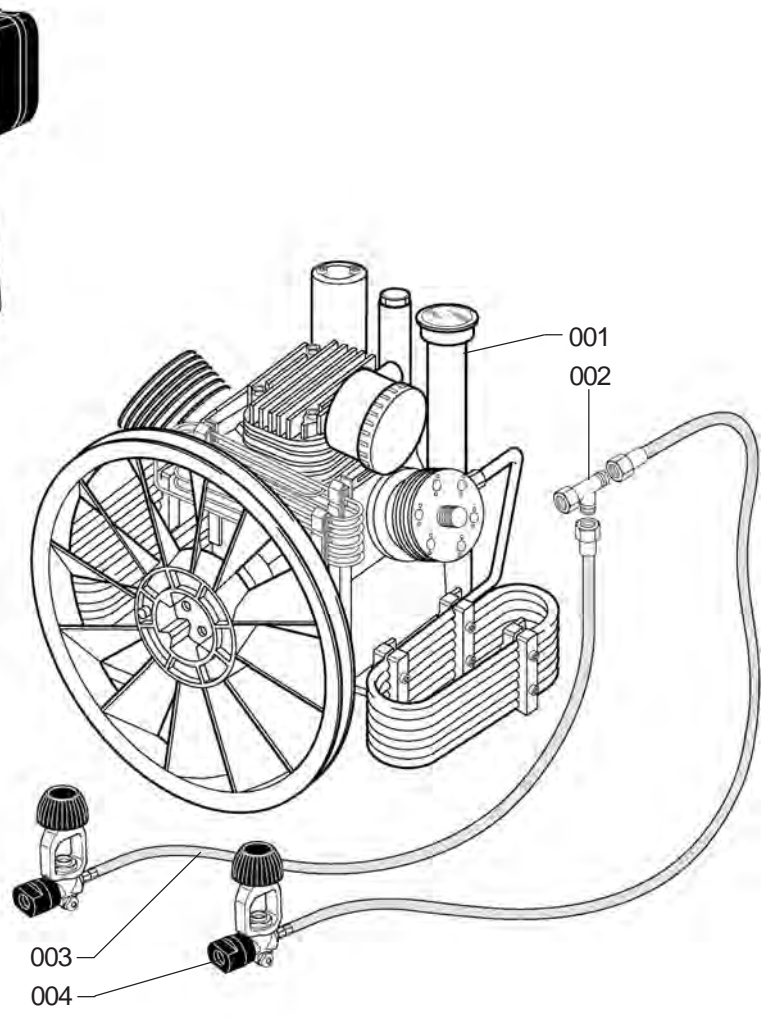

**MCH 13-16/DY**

POS.	CODE	DESCRIPTION
001		PUMP UNIT
002		CORNER 1/8 A "T"
003		STRAIGHT 1/8 - PIPE FITTING 6
004		BC INTERNAL COCK
006		DRIVING BELT A71
007		PULLEY
008		WASHER
009		TE SCREW
012		NUT
013		VIBRATION-DAMPING SUPPORT
014		TE SCREW
015		TCEI SCREW
016		BRACKET
021		DIESEL YANMAR ENGINE
022		STANDARD MCH 13-16/DY COVER
023		BASE



COLTRI SUB

AEROTECNICA COLTRI S.r.l.

Registered office: Via Rio Ponale, 7 - 25010 Rivoltella di Desenzano D/Garda - BRESCIA - ITALY

Factory: Via Colli Storici, 177 - 25010 San Martino della Battaglia - BRESCIA - ITALY

Tel. +39 030 9910297-9910301 - Fax +39 030 9910283

e-mail: coltrisub@coltrisub.it Internet: <http://www.coltrisub.it>