

# AEROTECNICA COLTRI

SERVICE

MANUAL

## HIGH PRESSURE COMPRESSORS SUPPLYING BREATHABLE AIR



MINI



SUPER

.....MINI E SUPER SILENT



MCH13-16/ET



MCH26-32/ET

.....COMPACT

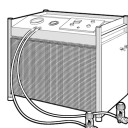

.....OPEN

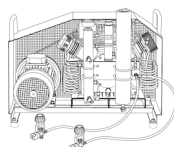

.....STANDARD

# INDEX

SAFETY PRECAUTIONS .....	2
GUARANTEE & SERVICING .....	2
TOOLS .....	3
SPECIAL TOOLS AND MEASUREMENT DEVICES .....	5

## 1 DISMANTLEMENT AND ASSEMBLY OF PANELS AND FRAMES

1.1 STANDARD .....	7
1.2 COMPACT .....	13
1.3 COMPACT 26-32 .....	22
1.4 SUPER SILENT .....	32
1.5 MINI SILENT .....	44
1.6 OPEN .....	53

## 2 PUMP UNIT

2.1 SECOND STAGE AIR INTAKE AND DISCHARGE VALVES .....	59
2.2 THIRD STAGE AIR INTAKE AND DISCHARGE VALVES .....	64
2.3 FIRST STAGE LAMELLAR AIR INTAKE AND DISCHARGE VALVE UNIT .....	72
2.4 FIRST STAGE SAFETY VALVE .....	76
2.5 SECOND STAGE SAFETY VALVE .....	79
2.6 CYLINDER VALVE .....	81
2.6.1 FIRST STAGE CYLINDER DISMANTLEMENT .....	81
2.6.2 SECOND STAGE CYLINDER DISMANTLEMENT .....	89
2.6.3 THIRD STAGE CYLINDER DISMANTLEMENT .....	93
2.6.4 VALVE DISMANTLEMENT .....	99
2.7 ELBOW FITTING DISMANTLEMENT .....	103

## 3 FILTERING SYSTEM

3.1 Condensate separator .....	109
3.2 Filter .....	112
3.3 Pressure maintenance valve .....	122
3.4 Safety valve .....	124

## 4 INSTRUMENTS

4.1 DIAGRAMS .....	126
--------------------	-----

## 5 ELECTRICAL PANEL

5.1 DIAGRAMS .....	128
5.1.1 "STANDARD" SERIES COMPRESSORS .....	129
5.1.2 "COMPACT" SERIES COMPRESSORS .....	132
5.1.3 "MINI E SUPER SILENT" SERIES COMPRESSORS .....	137
5.1.4 "OPEN" SERIES COMPRESSORS .....	139

## 6 PROGRAMMED MAINTENANCE

6.1 TUBE SIDE ASSEMBLY TORQUES .....	141
6.2 "COMPACT" PROGRAMMED MAINTENANCE .....	142
6.3 "MINI E SUPER SILENT" SERIES COMPRESSORS .....	153
6.4 "OPEN" SERIES COMPRESSORS .....	162
6.5 "STANDARD" SERIES COMPRESSORS .....	169

## 7 SPARE PARTS LIST ACCORDING TO NEEDS

7.1 SPARE PARTS MAINTENANCE .....	188
-----------------------------------	-----

## 8 COMPRESSOR TECHNICAL DATA

8.1 STANDARD .....	191
8.2 COMPACT .....	193
8.3 MINI E SUPER SILENT .....	195
8.4 OPEN .....	197
8.5 TABELLA CONVERSIONE bar/psi .....	199

## SAFETY PRECAUTIONS

Exclusively qualified and specialised personnel, authorised by AEROTECNICA COLTRI can carry out the operations shown in this manual. This manual must be read carefully and consulted in case of need.

**THE SPECIFIC COMPRESSOR'S "INSTRUCTIONS MANUAL" AND THE ENCLOSED "SAFETY PRECAUTIONS" MANUAL MUST BE CONSIDERED AN INTEGRAL PART OF THIS MANUAL.**

All personnel authorised to carry out reparations must be identified and authorised in written form by AEROTECNICA COLTRI after having taken the training course regarding:

- ordinary and special maintenance of electrical and mechanical parts;
- reparation and substitution of electrical and mechanical parts;
- use of individual protection devices (DPI);
- safety operations;
- restrictions of use;
- remaining risks.

Any tampering action done to the compressor or to its components (including the use of not original spare parts) not authorised by AEROTECNICA COLTRI S.r.l. lifts the manufacturer from any civil or penal responsibility.

**ALL REPARATIONS MUST BE CARRIED OUT WITH THE COMPRESSOR IN THE OFF POSITION, WITH POWER SUPPLY DISCONNECTED, AND WITH PUMP UNIT DEPRESSURISED. ALL ENERGY SOURCES MUST BE BLOCKED.**

## GUARANTEE AND SERVICING

### GUARANTEE

**AEROTECNICA COLTRI S.r.l.** guarantees the compressors against any defect or fault in the design, manufacturing and against any fault in the materials for a period of twelve months from the delivery of the machine. The Client must report the defect or faults found within eight days from their discovery to **AEROTECNICA COLTRI S.r.l.**, in written form, by means of a registered letter with advice of receipt or telegram under penalty of cancellation of the guarantee.

The guarantee is only valid against defects or faults arising with the compressor used under proper operating conditions according to the instructions given in this manual and with the maintenance operations carried out at the intervals as provided for.

The guarantee expressly excludes any faults arising as a result of improper use of the machine, atmospheric agents,

and of damage due to transport. The guarantee does not cover the expendable materials and materials required for the periodic maintenance which are at the Client's entire expense. The guarantee will, in any case, become automatically null and void if the compressor is tampered with or if it has been serviced by technicians who are not authorised to do so by **AEROTECNICA COLTRI S.r.l.**

Any compressor that is acknowledged to be faulty due to defects in the design, manufacturing or materials used, will be repaired or replaced free of charge by **AEROTECNICA COLTRI S.r.l.** at its manufacturing plant in San Martino della Battaglia (BRESCIA). Transport and shipping expenses for spare parts or expendable materials are entirely on Client's charge.

Should service under guarantee be necessary at the Client's premises, the latter will be responsible for travel and transport costs for the staff sent out by **AEROTECNICA COLTRI S.r.l.**

Taking delivery of the machines and / or any faulty component or the transfers, for the inspection of the defects or faults as notified by the Client, will not, however, denote any implicit admission regarding the effectiveness of the guarantee.

Repairs and/or replacements carried out by **AEROTECNICA COLTRI S.r.l.** during the guarantee period will not extend the duration of the same.

Acknowledgement of the guarantee does not itself imply any liability for compensation on the part of **AEROTECNICA COLTRI S.r.l.**

**AEROTECNICA COLTRI S.r.l.** is not held responsible for injury to persons or damage to property or for any other direct or indirect damage (production stop, missed profit, etc.) ascribable to the compressors defects or faults, except for recognisable cases of gross default.

### SERVICING

The **AEROTECNICA COLTRI S.r.l.** technicians are available for any routine or special maintenance servicing.

The request for technical servicing must be sent to **AEROTECNICA COLTRI S.r.l.** at the following address:

### **AEROTECNICA COLTRI S.r.l.**

Via Colli Storici, 177  
25010 San Martino della Battaglia (BRESCIA)

Fax: 030 9910283  
e-mail: coltrisub@coltrisub.it

TOOL NEEDED



- Socket wrench size 8



- Socket wrench size 13



- Socket wrench size 32



- Wrench size 10



- Wrench size 13



- Wrench size 14 and 15



- Wrench size 16



- Wrench size 17 and 19



- Wrench size 24



- Wrench size 27



- Wrench size 32



- Thread locking Loctite



- Allen spanner size 4



- Allen spanner size 5



- Allen spanner size 6



- Allen spanner size 8



- Allen spanner size 10

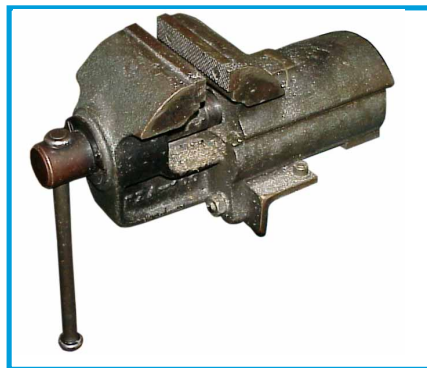

- Work bench vise



- Philips screwdriver



- Flat screwdriver



- Round-nose pliers



- Pliers for internal c-clip



- Pliers for external c-clip



- Adjustable wrench



- Hammer



- Mallet

### SPECIAL TOOLS AND MEASUREMENT DEVICES



- Special key for valves



- Fan Hub extractor



- Dial gauge



- Micrometer



- Thickness gauge



- Ring extractor



- Special compass key



- Special key for HP condensate discharge electric valve and coil unit

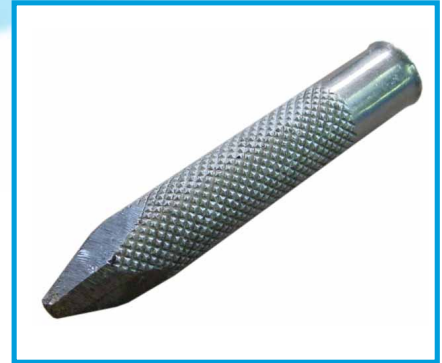

- Graver



- Pliers for ring clamping.

**WARNING:**

**FOR ANY INFORMATION INTENTIONALLY NOT SPECIFIED IN THIS MANUAL, PLEASE ASK FOR SERVICING FROM AEROTECNICA COLTRI.**

**“STANDARD” MODEL COMPRESSORS: PANELS AND FRAMES**

**LEVEL OF SERVICING DIFFICULTY**

SIMPLE





MEDIUM

DIFFICULT

**EXPECTED TIME NEEDED FOR DISMANTLEMENT AND ASSEMBLY: 10 minutes**

**TOOLS NEEDED**

 Wrench size 10	 Allen spanner size 5			

**SPECIAL TOOLS**

--	--	--	--

# 1 PANELS AND FRAMES

## 1.1 STANDARD (ELECTRIC VERSION)

Unscrew Allen screws fixing the bracket to the compressor's protection panel by using Allen spanner size 5 and wrench size 10 (for the lock nut).

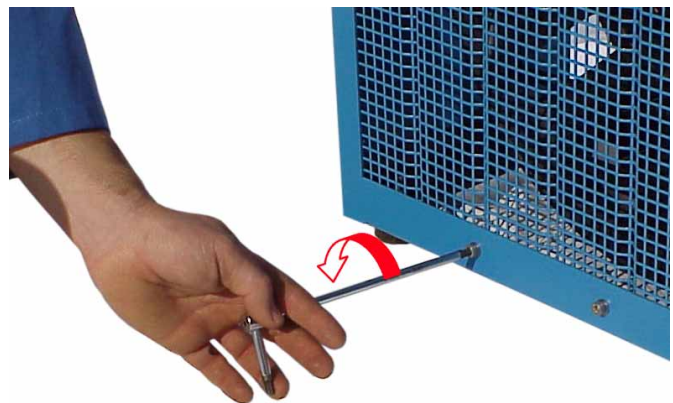

Unscrew Allen screws fixing the frame panel.

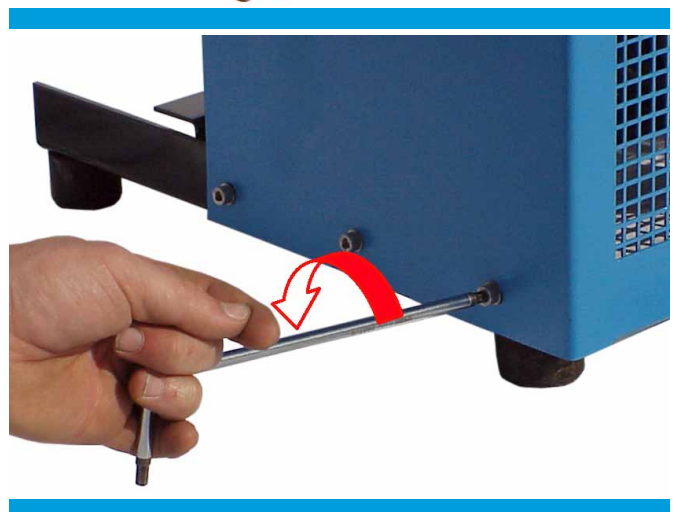

STANDARD  
ELECTRIC VERSION

Unscrew the screw fixing the bracket to the first stage unit cover.

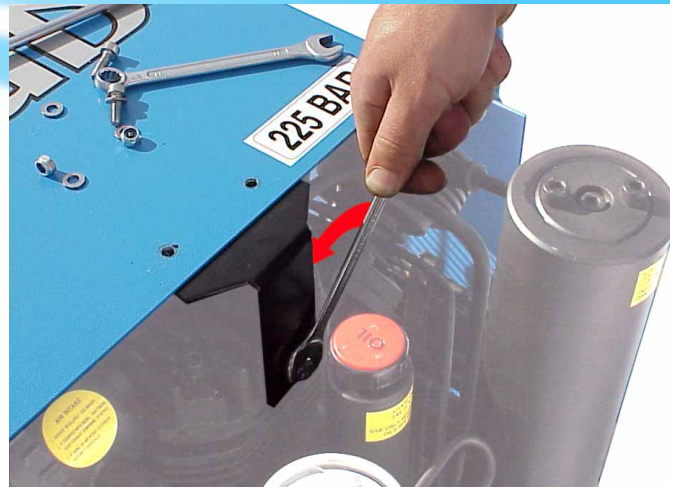

Remove the protection panel.

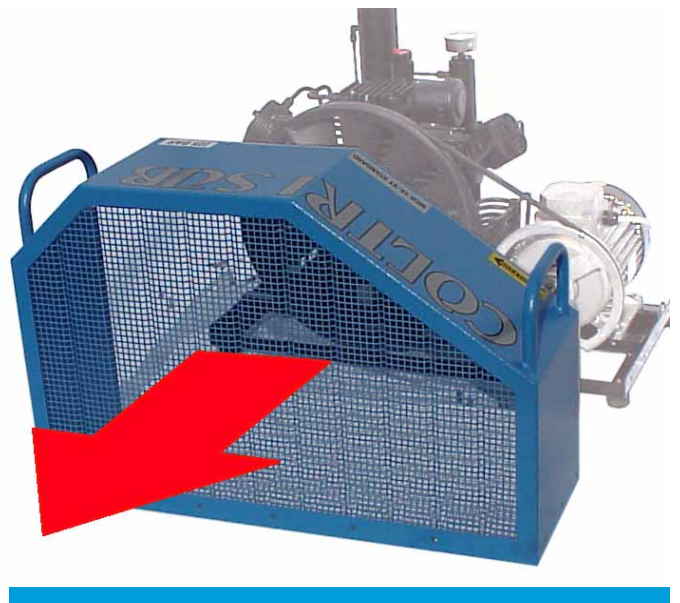

STANDARD  
ELECTRIC VERSION

**“STANDARD” MODEL COMPRESSORS: PANELS AND FRAMES  
(petrol/diesel version)**

**LEVEL OF SERVICING DIFFICULTY**

SIMPLE



MEDIUM

DIFFICULT

**EXPECTED TIME NEEDED FOR DISMANTLEMENT AND ASSEMBLY: 15 minutes**

**TOOLS NEEDED**

 <p>Wrench size 10</p>	 <p>Allen spanner size 5</p>	 <p>Allen spanner size 6</p>	 <p>Socket wrench size 13</p>	

**SPECIAL TOOLS**

--	--	--	--

## 1.1 STANDARD (PETROL/DIESEL VERSION)

Unscrew Allen screws fixing the bracket to the compressor's protection panel using Allen spanner size 6 and wrench size 10 (for the lock nut).



Unscrew the screw fixing the bracket, between the protection panel and the separator holding bracket using Allen spanner size 5 and wrench size 10 (for the lock nut).



Unscrew the screw fixing the motor (petrol) bracket, using Allen spanner size 6.

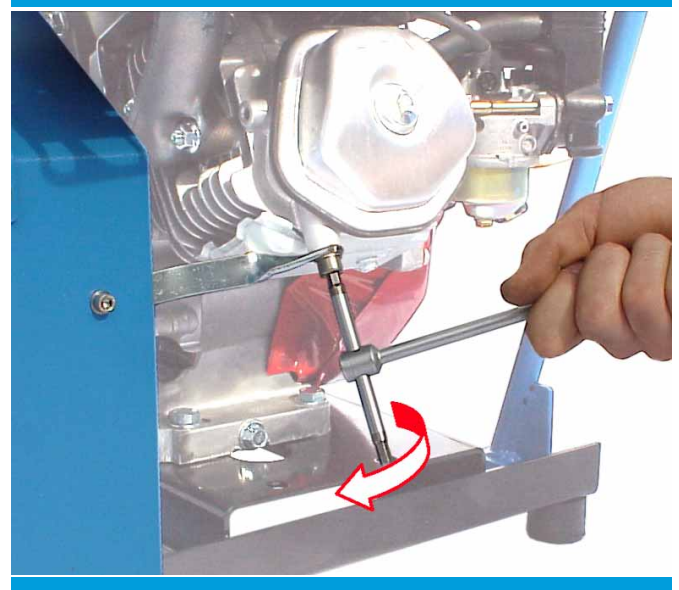

**STANDARD**  
PETROL/DIESEL VERSION

Unscrew the screws fixing the handle using Allen spanner size 6.

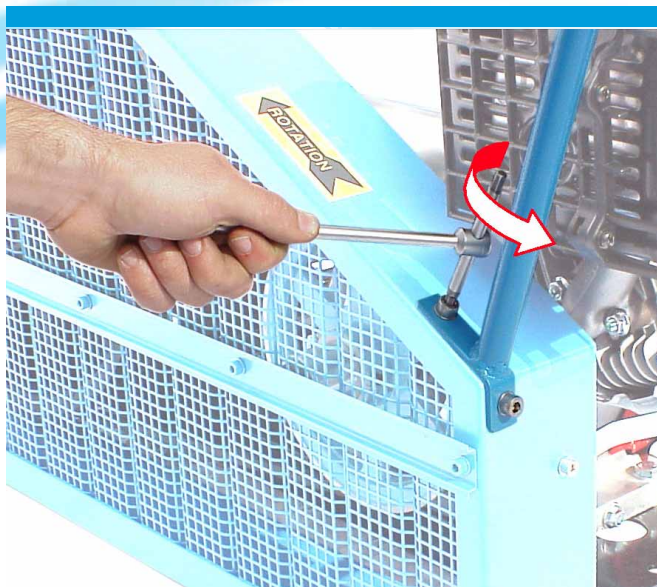

Unscrew the screws fixing the panel to the base of the frame using socket wrench size 13.



Taking care not to damage the paint or frame itself, (it is advisable to position cardboard or cloth on the floor) fold back the entire compressor to unscrew the protection guard from the frame, using an Allen spanner size 5 and wrench size 10 (for the lock nut).

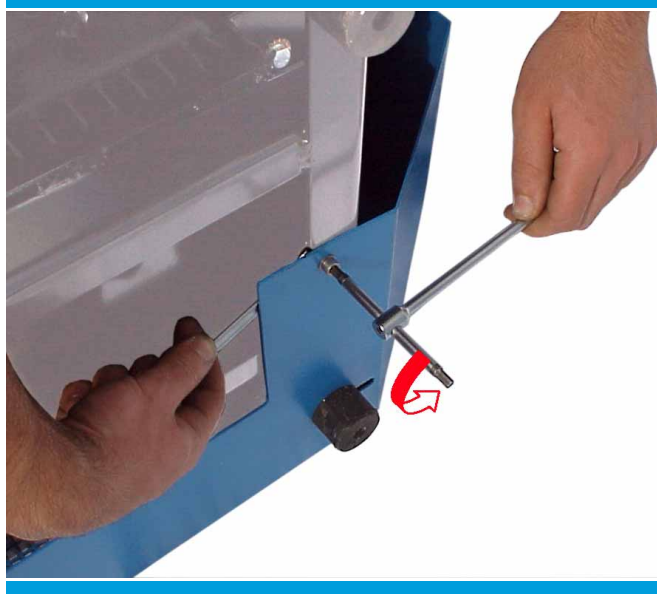

**COMPRESSOR “COMPACT” MODEL PANELS AND FRAMES**

<b>LEVEL OF SERVICING DIFFICULTY</b>	SIMPLE ●	MEDIUM	DIFFICULT
--------------------------------------	-------------	--------	-----------

**EXPECTED TIME NEEDED:**

**TOOLS NEEDED**

 Wrench size 10	 Wrench size 14-15	 Wrench size 17	 Wrench size 24	 Allen spanner size 5
 Flat screwdriver		 Philips screwdriver		 Socket wrench size 8
 Round-nose pliers				

**SPECIAL TOOLS**

 Valve key			
--------------------------------------------------------------------------------------------------	--	--	--

## 1.2 COMPACT

Drain air out of filters two hoses.

Using wrench size 17, disconnect the two hoses.

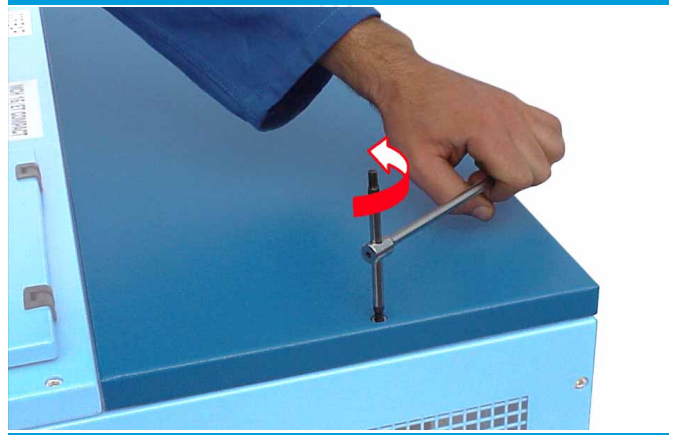

Using Allen spanner size 5, unscrew the screws fixing the two superior panels - 4 on the front and 2 on the back.

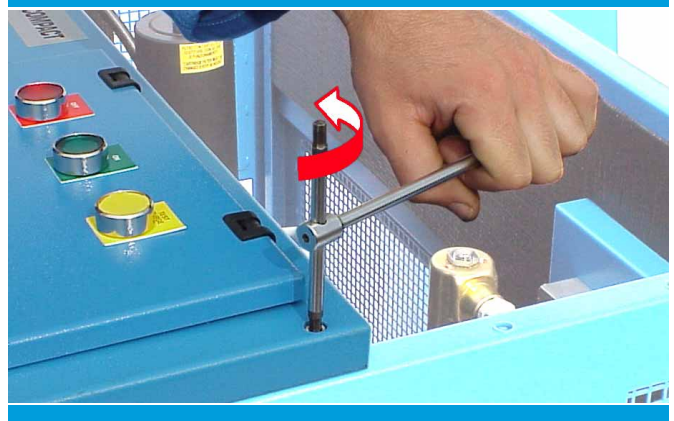

Using wrench size 17, unscrew the hose fitting connecting the maintenance valve to the block.



Disconnect the power supply cable from the plug unscrewing the wires from the internal terminal board.

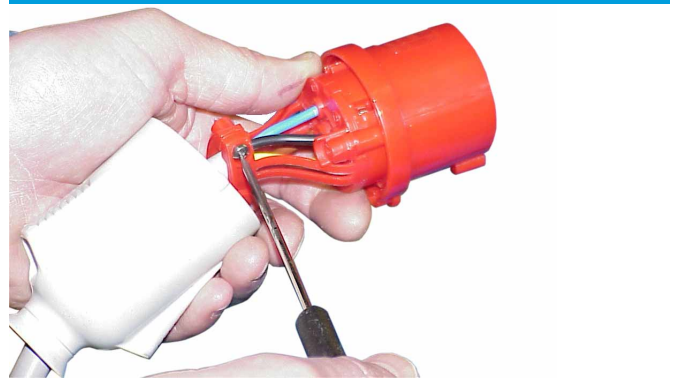
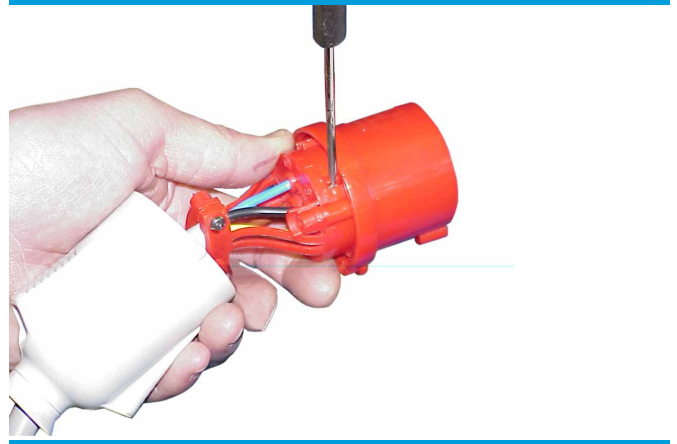

Using round nose pliers, loosen the wire clamp found on the back panel and pull out the electric cable completely.

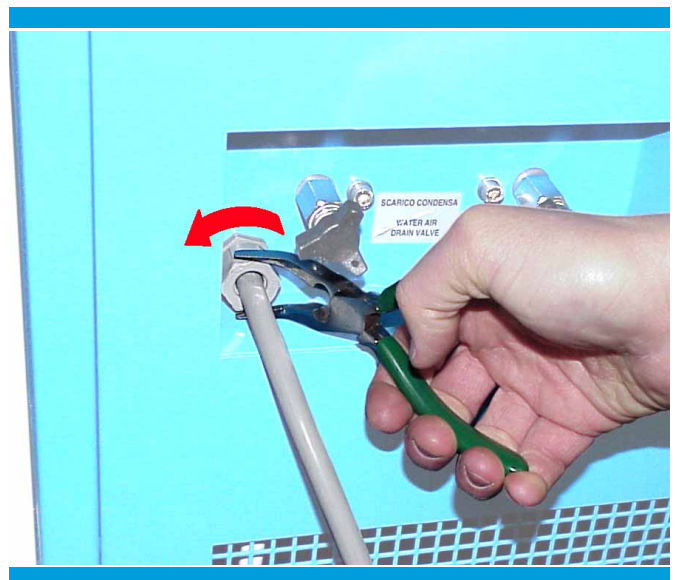

Using the special key (code SC-000-490) unscrew the nut of the HP condensate discharge electric valve (code 13-04-02222) and remove it.



Using a Philips screwdriver, unscrew the screw locking the fitting to the LP condensate discharge solenoid valve (cod. 13-04-0221) and release the fitting taking care with its gasket.

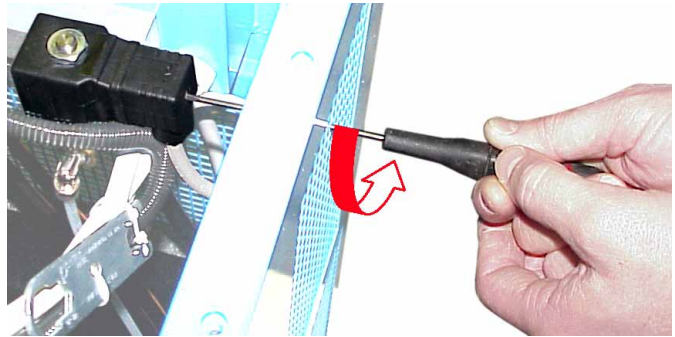

Using the screwdriver, unscrew the screw locking the fitting to the pressure switch (cod. SC000310 for 280 bar and cod. SC000315 for 330 bar) and release the fitting taking care with its gasket.

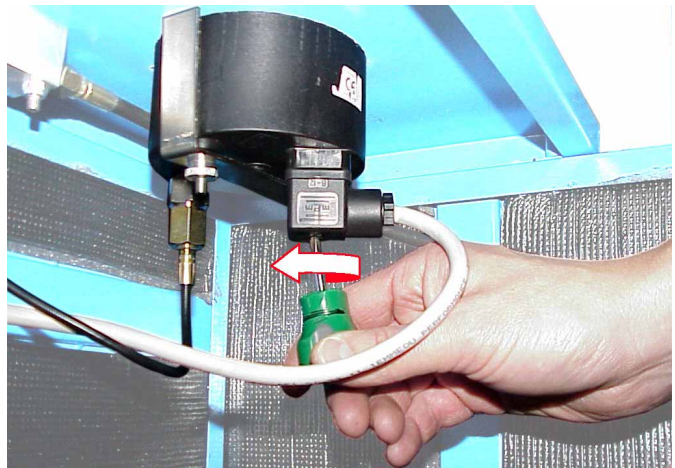

Using the screwdriver, unscrew the screws fixing the protection guard of the motor's terminal board.



Using socket wrench size 8, disconnect 3 wires (black-blue-brown) coming from the electric supply cable from the motor's terminal board.

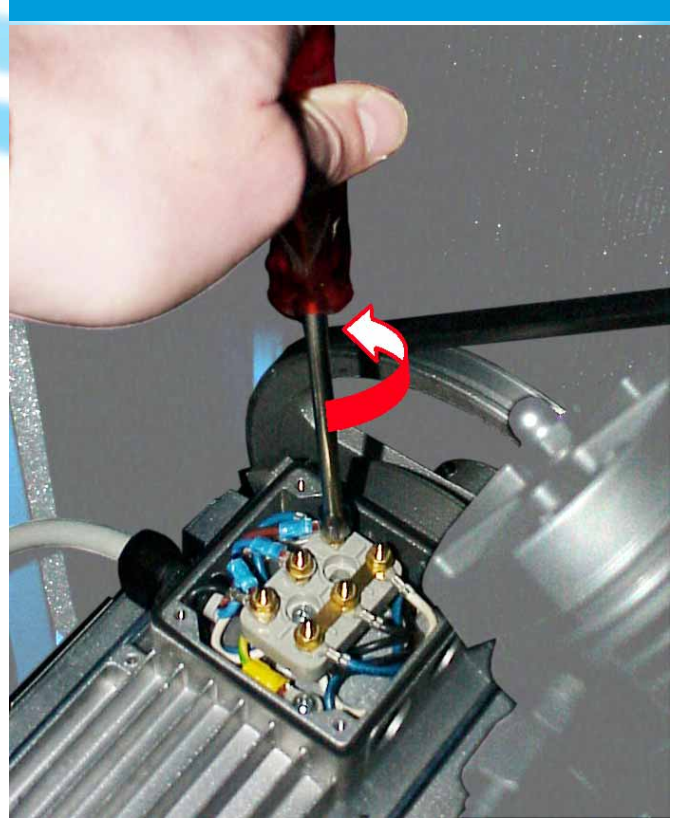

Using the Philips screwdriver, unscrew the screw locking the grounding wire (green-yellow) from the motor's terminal board.

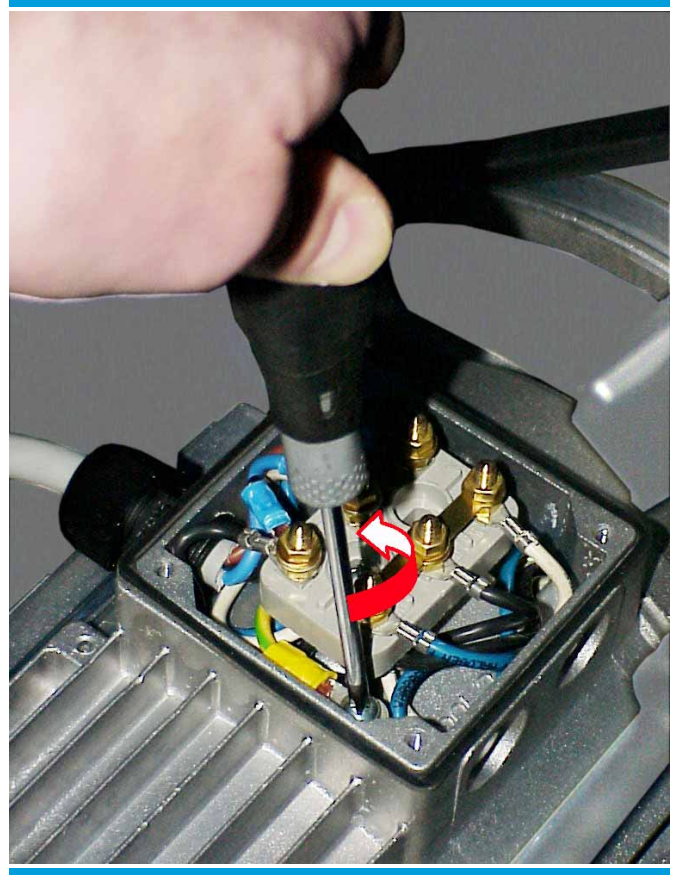

Using round nose pliers, loosen the wire clamp found on the motor's terminal board box and pull out the electric cable completely.

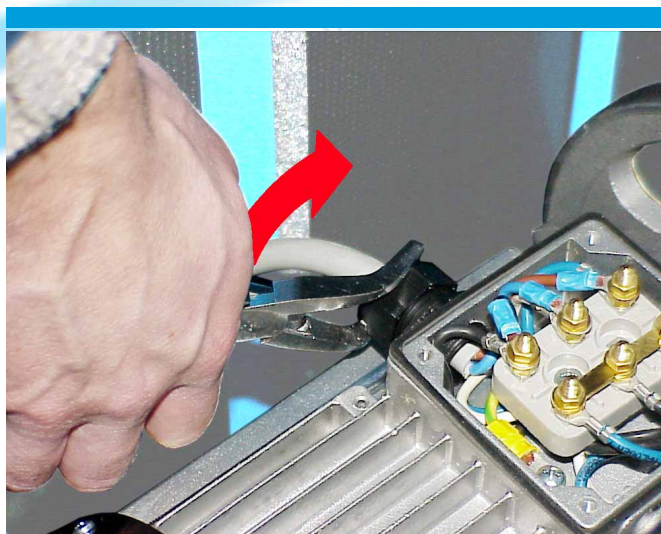

Unscrew the Allen screws locking the right and left protection panels (4 for each panel) .

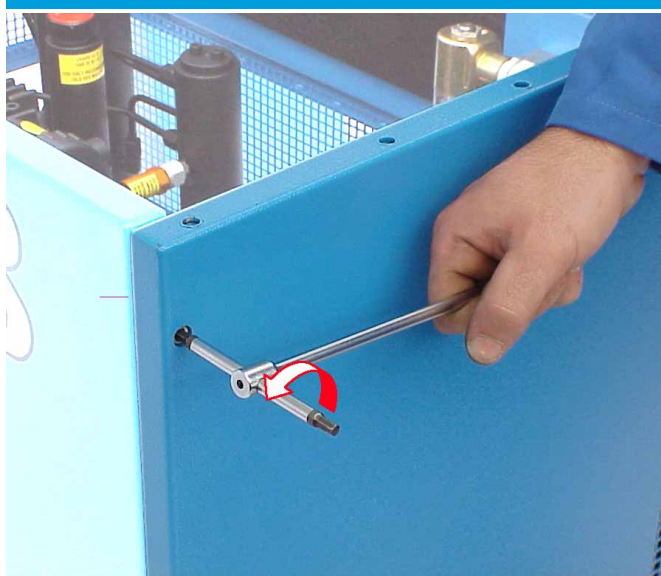

Before dismantling the frontal panel discharge the oil by unscrewing the discharge tap with wrench size 24.

Use a suitable container to collect the oil.

**Do not discharge the oil in the gutter or in the drain.**



Next open the appropriate tap.



Using a Philips screwdriver disconnect the tube connecting the oil discharge fitting by unscrewing the metal clamp.

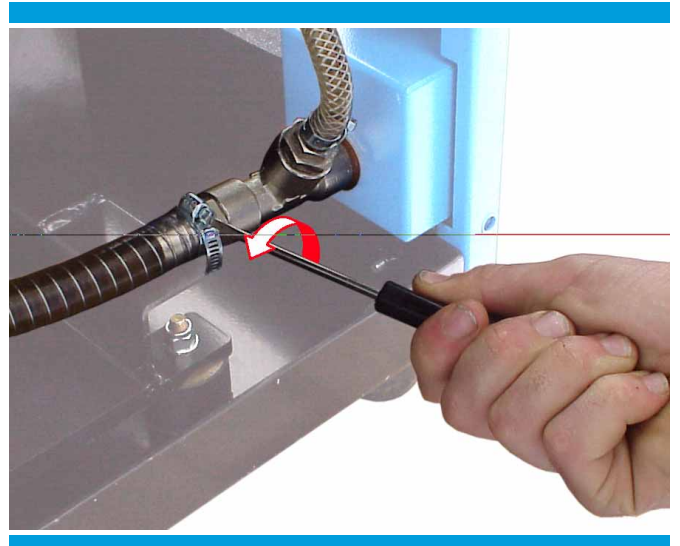

Using wrench size 14 disconnect the white plastic discharge tube of the crankcase.

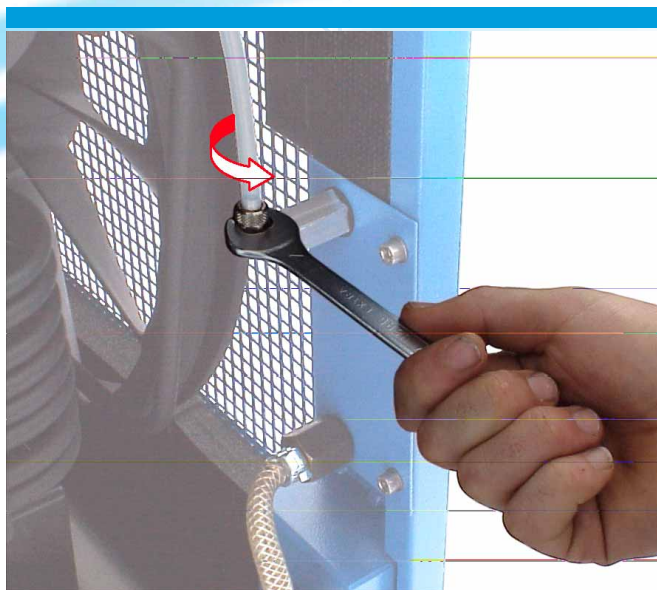

Unscrew the 2 Allen screws clamping the frontal protection panel to the frame using Allen spanner size 5.



Disconnect the 3 condensate discharge hoses using wrench size 17 (14 and 15 for earlier versions).

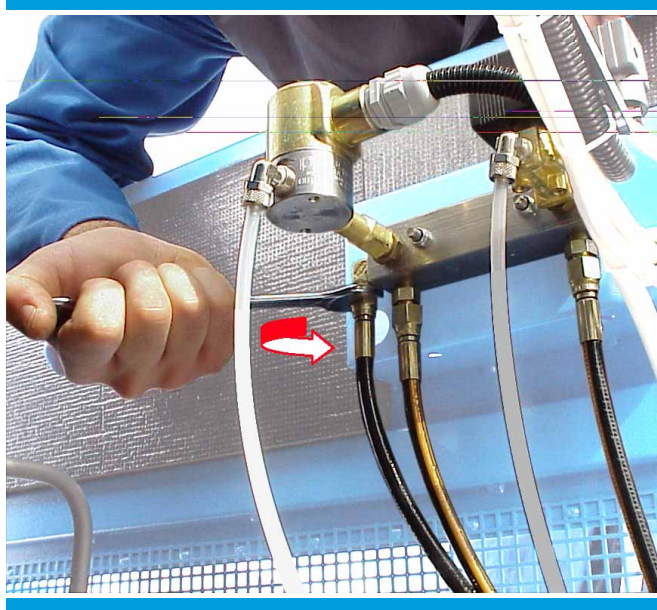

Disconnect the 2 plastic tubes from the condensate container (by connection).



Unscrew the Allen screws locking the back panel to the frame and remove it.



**COMPRESSOR “COMPACT 26/32” MODEL PANELS AND FRAMES**

<b>LEVEL OF SERVICING DIFFICULTY</b>	SIMPLE	MEDIUM 	DIFFICULT
--------------------------------------	--------	--------------------------------------------------------------------------------------------	-----------

**TEXPECTED TIME NEEDED:**

**TOOLS NEEDED**

				
Wrench size 14-15	Wrench size 17	Allen spanner size 5	Socket wrench size 8	Round-nose pliers
				
Flat screwdriver		Philips screwdriver		

**SPECIAL TOOLS**

			
Valve key			

### 1.3 COMPACT 26/32

**NOTE:** Before disconnecting the hoses, mark each one with a label, in order to make re-assembly operations simpler.

Before dismantling the front panel, discharge the oil by unscrewing the 2 discharge taps. Next open the appropriate taps.

Use a suitable container to collect the oil.

**Do not discharge the oil in the gutter or in the drain.**

Unscrew the 6 Allen screws locking the two lateral panels and remove them.

Disconnect the tubes from the loading fitting found on the top panel (internally) by working on the clamps.

Unscrew the 4 top cap nuts and remove the top conveyor and the cover.

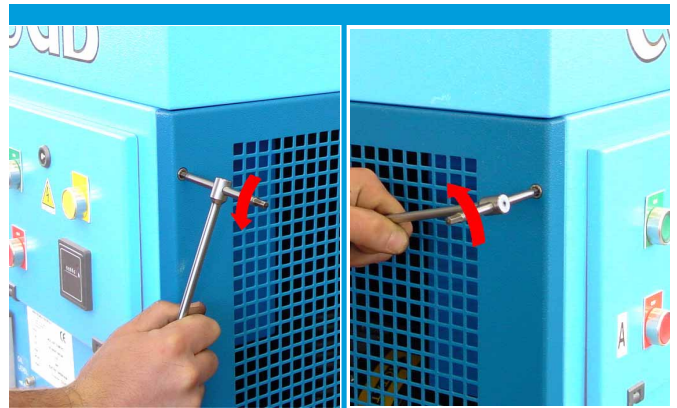
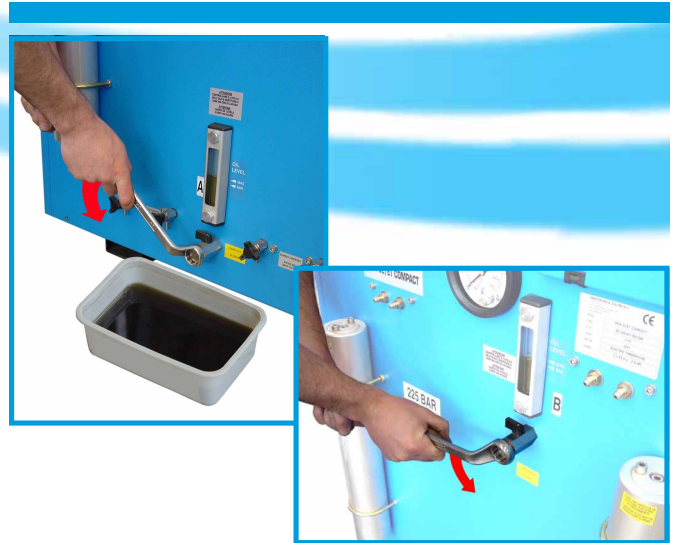

COMPACT  
26 / 32

Disconnect the 4 white plastic tubes connected to the condensate container from the internal back panel.



Remove the grating back panel covering the fan and lift it from its seat.

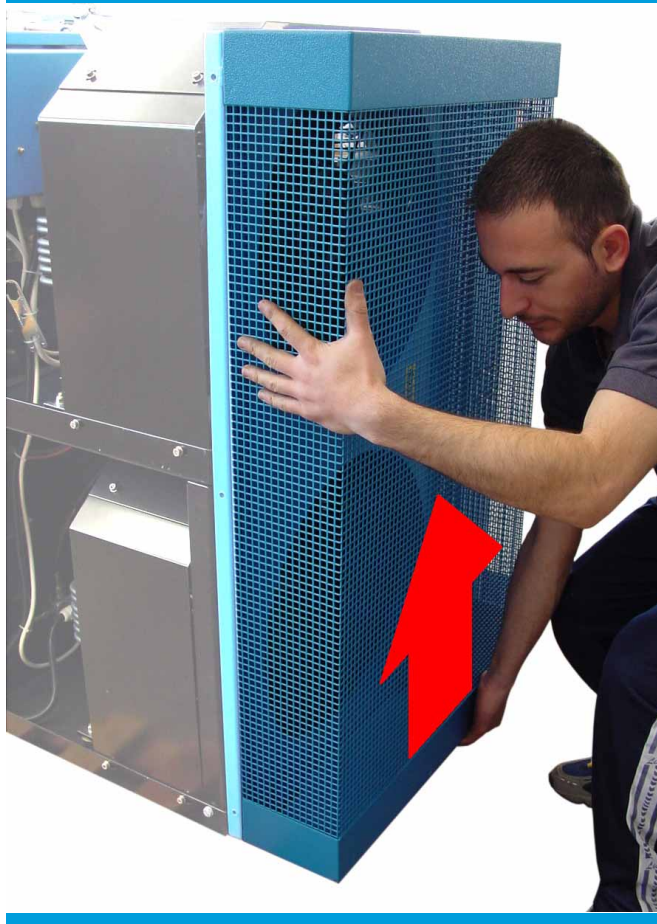

**WARNING:**  
THE PANEL COVERING IS HEAVY!

Unscrew the Allen screws and remove the back protection panel.



Disconnect the electric supply cable from the plug by unscrewing the wires from the internal terminal board.

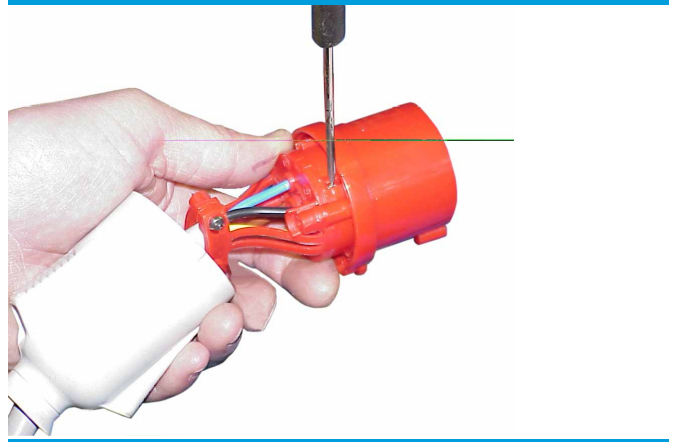

Using round-nose pliers, loosen the wire clamp found on the back panel and pull the electric cable out completely.



Unscrew the Allen screws and remove the two metal internal conveyors.

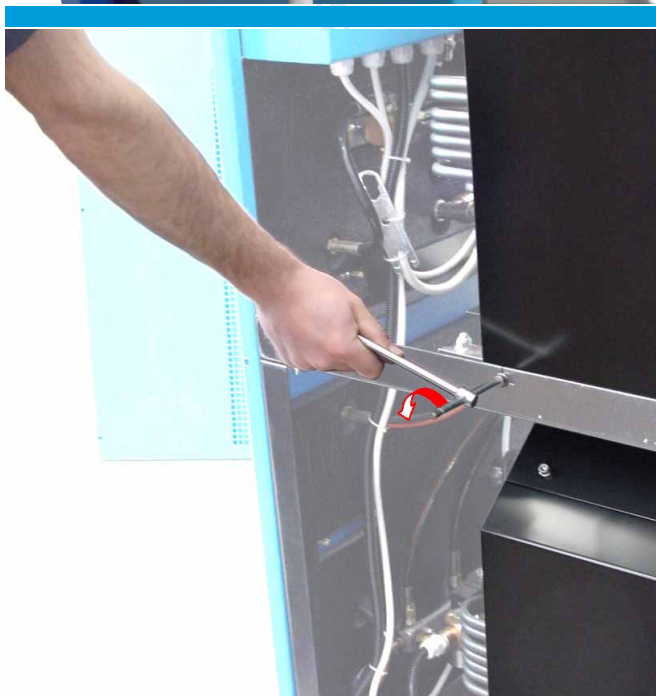

Disconnect the 3 tubes connected to the oil discharge fittings by unscrewing the metal clamps.

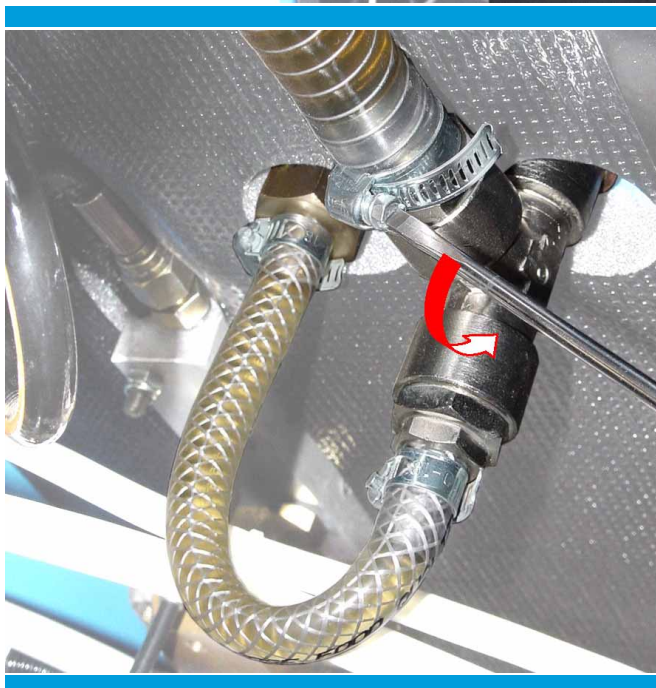

Using the special key supplied (cod. SC000490) unscrew the nut of the two HP condensate discharge electric valves (cod. 13-04-0222) and remove the coils.

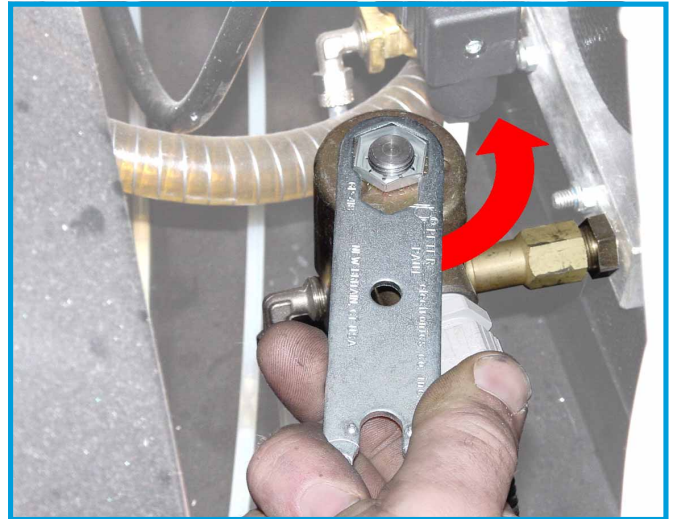

Using the Philips screwdriver, unscrew the screws locking the fittings to the relevant LP condensate discharge electric valves (cod. 13-04-0221) and unhook the fittings taking care with their gaskets.

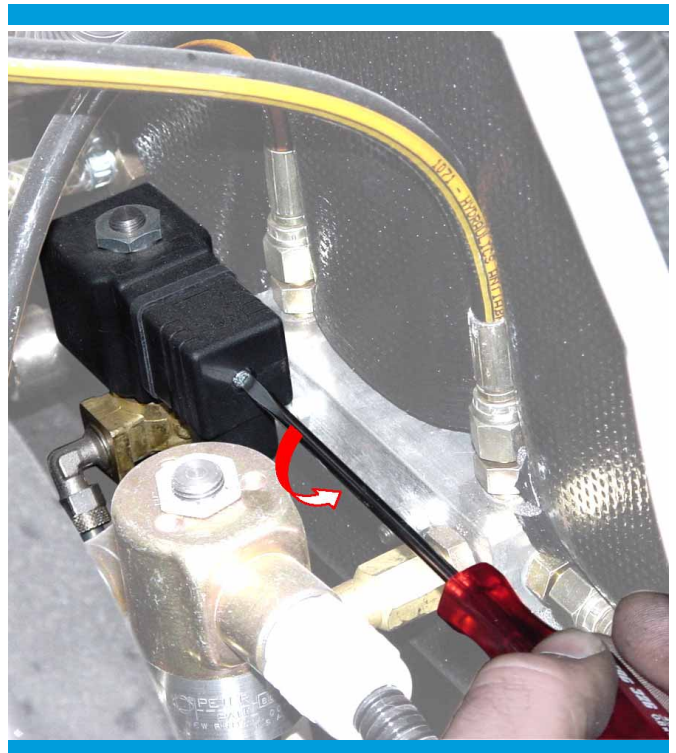

COMPACT  
26 / 32

Using Philips screwdriver, unscrew the screws locking the motor's terminal board protection guard.



Using socket wrench size 8, disconnect the 3 wires (black / blue / brown) coming from the electric power supply cable from the motor's terminal board.



Using Philips screwdriver, unscrew the screw locking the grounding wire (yellow/green) from the motor's terminal board.

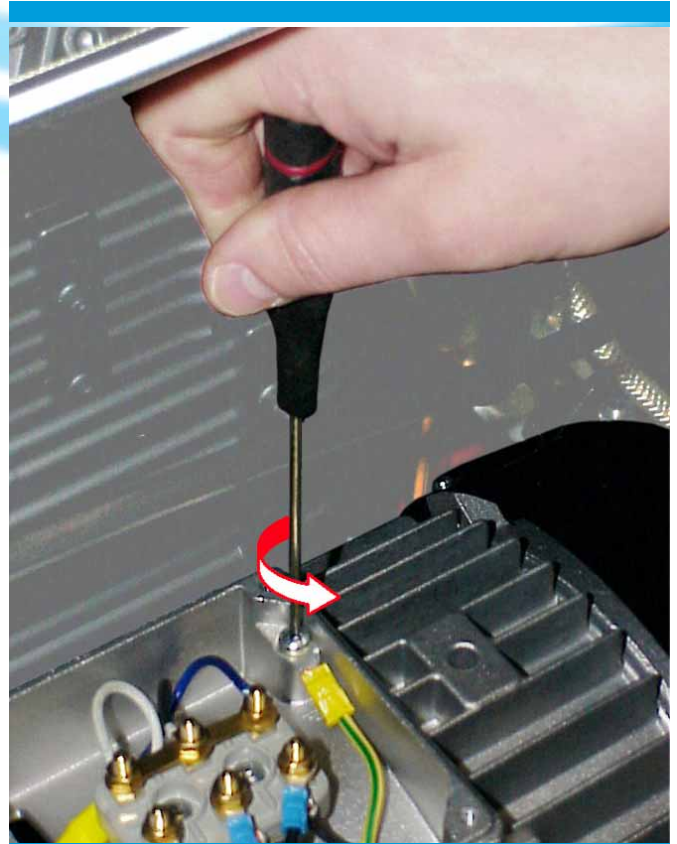

Using round-nose pliers loosen the wire clamp found on the motor's terminal board box and pull the electric cable out completely.

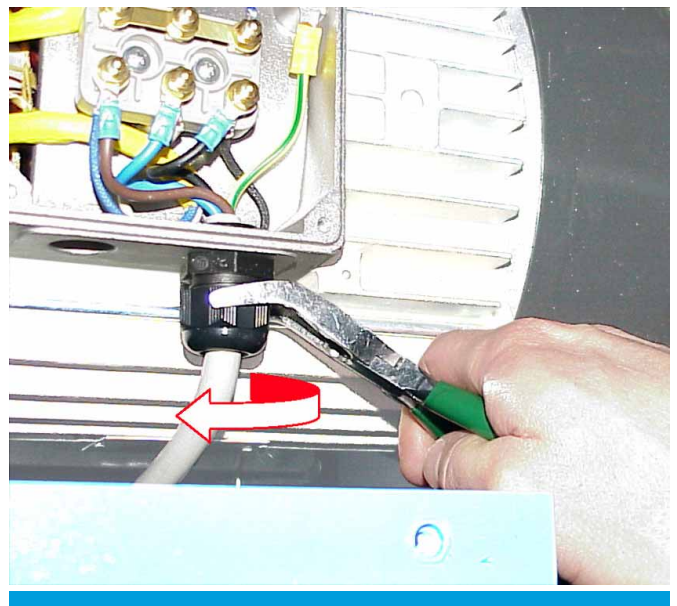

Using wrench size 17 (14 and 15 for earlier versions) disconnect the 4 hoses (2 for each separator) connecting the bottom condensate separator to the electric valve block.

Follow this procedure for each separator.

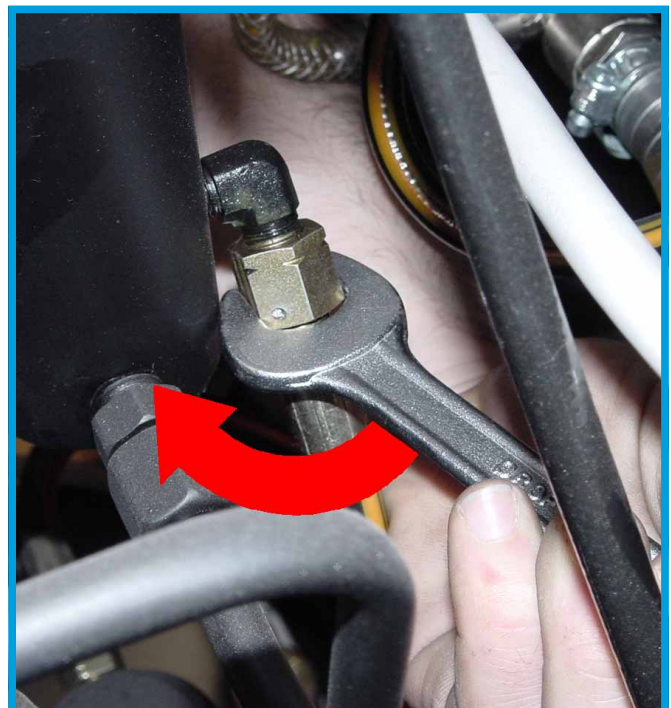
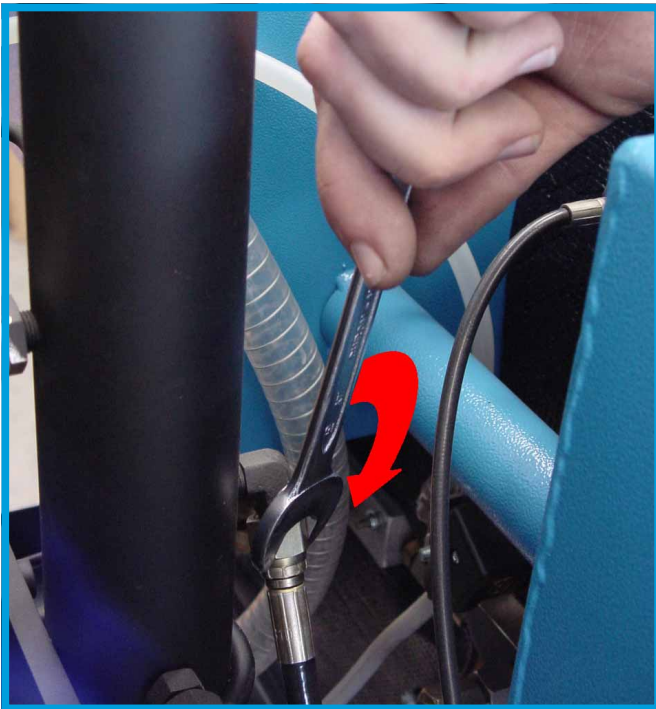
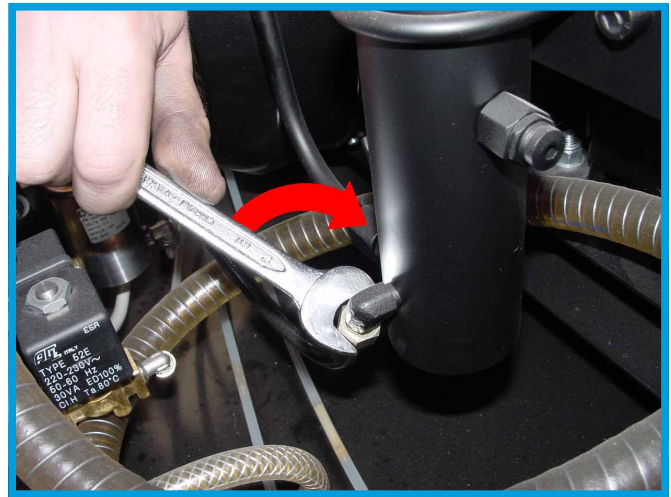
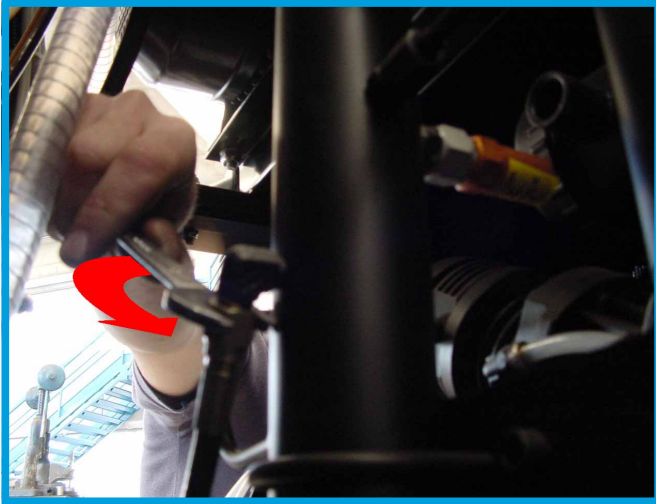

Using wrench size 17 (14 and 15 for earlier versions), disconnect the top hoses (2) connecting each separator to the molecular sieve filter.

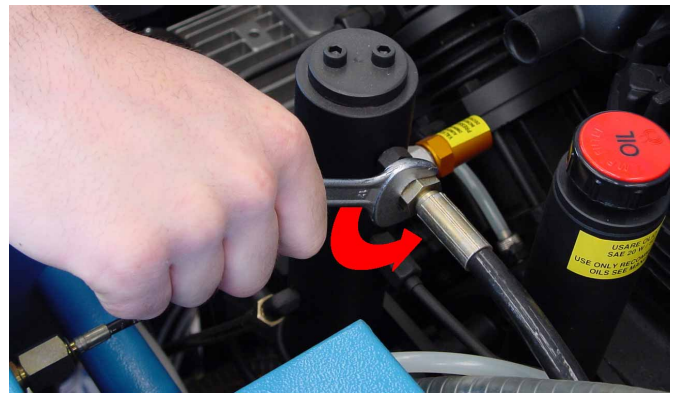
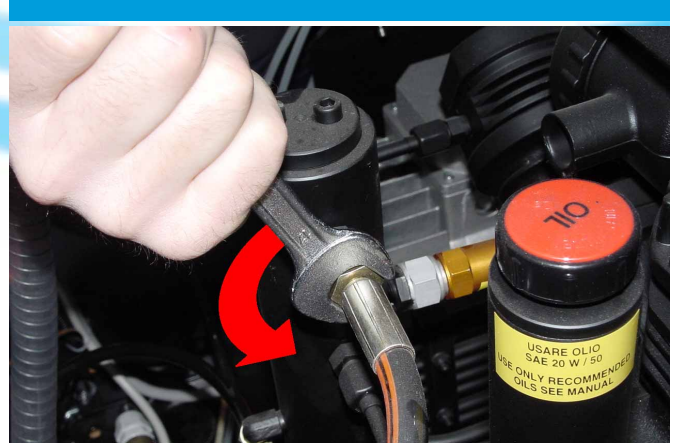

In order to remove the front panel, unscrew the 4 screws using Allen spanner size 5.





**COMPRESSOR “SUPER SILENT” MODEL PANELS AND FRAMES**

<b>LEVEL OF SERVICING DIFFICULTY</b>	SIMPLE	MEDIUM 	DIFFICULT
--------------------------------------	--------	-----------------------------------------------------------------------------------------------	-----------

**EXPECTED TIME NEEDED : 70 minutes**

**TOOLS NEEDED**

 Wrench size 10	 Wrench size 14-15	 Wrench size 17	 Wrench size 24	 Allen spanner size 5
 Flat screwdriver	 Philips screwdriver	 Socket wrench size 8	 Round-nose pliers	

**SPECIAL TOOLS**

 Valve key			
-------------------------------------------------------------------------------------------------	--	--	--

## 1.4 SUPER SILENT

**NOTE:** Before disconnecting the hoses, mark each one with a label, in order to make re-assembly operations simpler.

Remove the back conveyor by lifting it.

**WARNING:**  
THE CONVEYOR IS HEAVY!

Insert the appropriate key in the lock and turn it anti-clockwise. Remove the 2 topside panels.

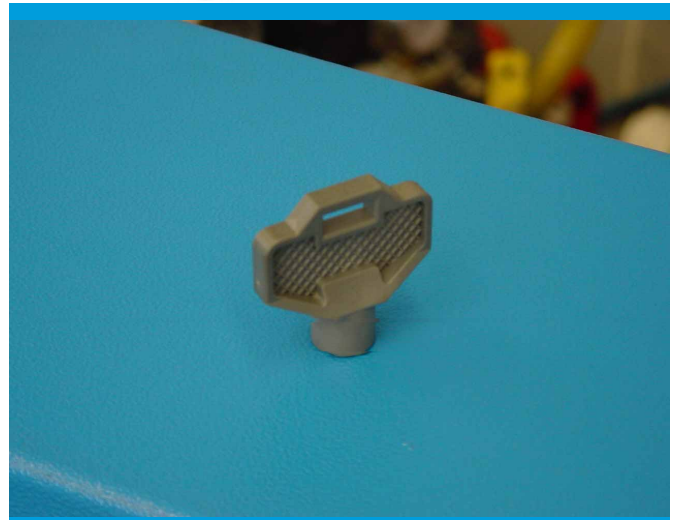

Using wrench size 10 unscrew the 4 top cap nuts and remove the top conveyor and the cover.



Unscrew the 4 Allen screws and remove the internal metal conveyor using Allen spanner size 5.

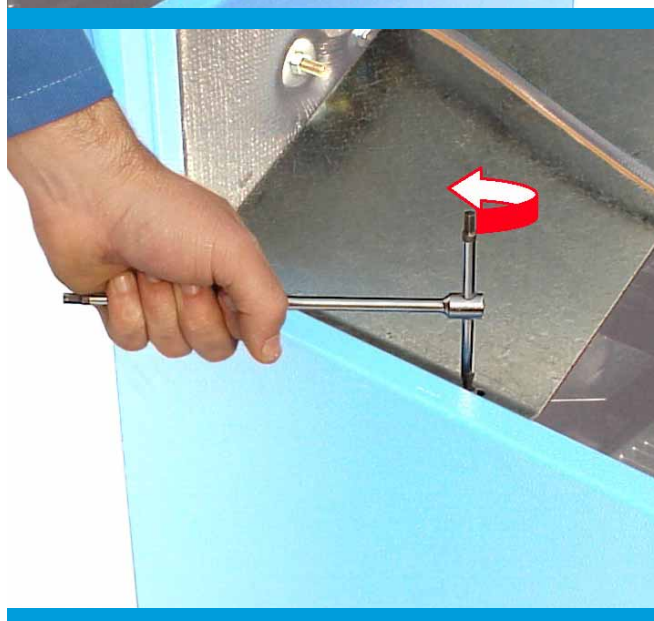

S U P E R  
S I L E N T

Using Allen spanner size 5 unscrew the 4 Allen screws and remove the bottom left side panel.



Extract the condensate tank from its seat and disconnect the 2 plastic tubes (quick connection).

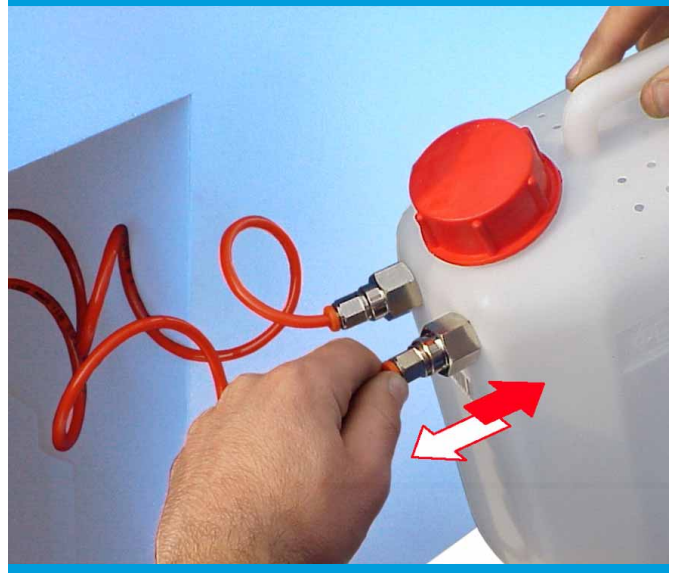

Using Allen spanner size 5 unscrew the 4 screws locking the bottom right side panel and remove it.



Disconnect the 3 hoses of the final condensate separator from the back protection panel (internally);

the hose fitting found lower down must be unscrewed from the outside using wrench size 17 (14 and 15 for earlier versions).

Unscrew the Allen screws locking the back protection panel and remove it using Allen spanner size 5.

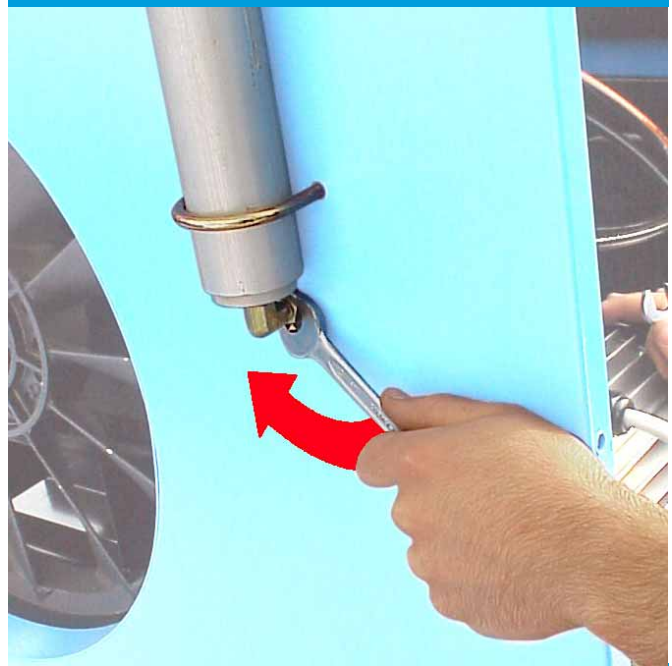
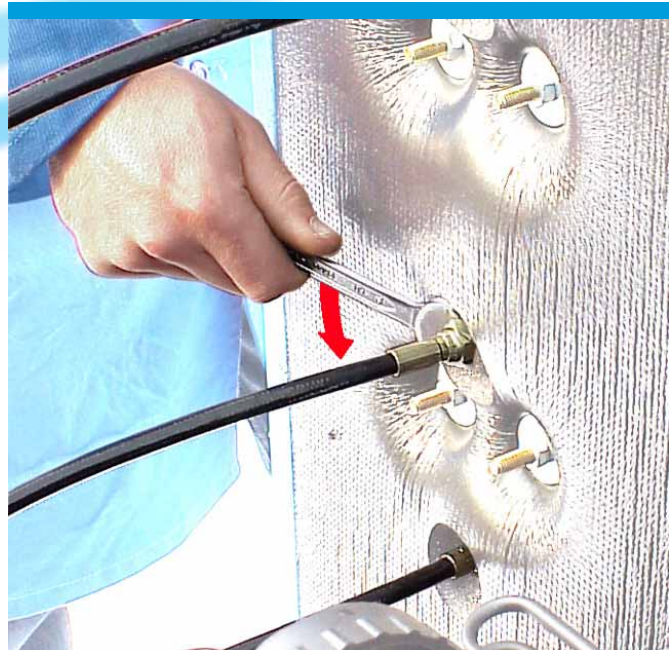

Before removing the front panel the following operations must be carried out:

- disconnect the electric power supply cable from the plug by unscrewing the wires from the terminal board.

SUPER  
SILENT

Using round-nose pliers loosen the wire clamp found on the back panel and pull the electric cable out completely.

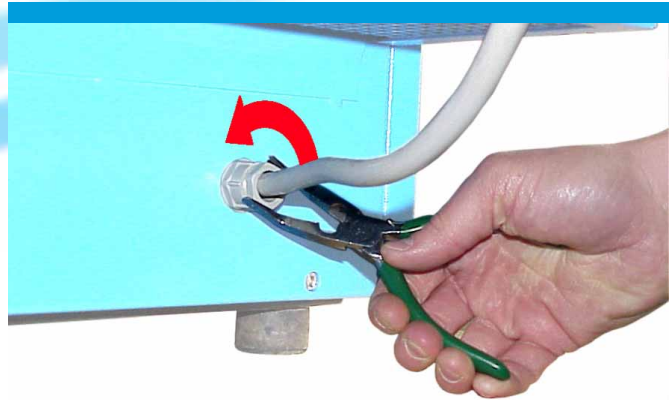

Using the special key supplied (cod. SC000490) unscrew the HP condensate discharge electric valve nut (cod. 13-14-0222) and remove the coil.

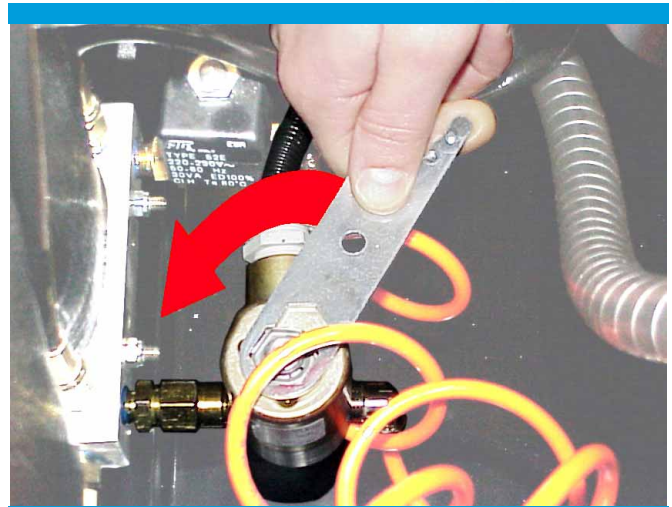

Using the Philips screwdriver, unscrew the screw locking the fitting to the LP condensate discharge electric valve (cod. 13-04-0221) and unhook the fitting taking care with its gasket.



Using the Philips screwdriver, unscrew the screw locking the fitting to the pressure switch (cod. SC000310 for 280 bar and cod. SC000315 for 330 bar) and unhook the fitting taking care with its gasket.

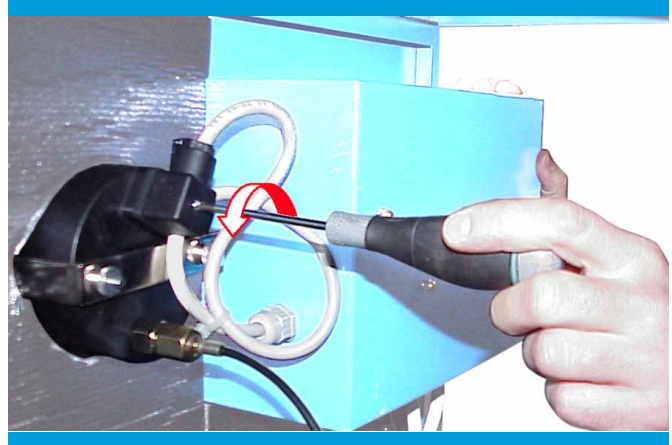

Using the Philips screwdriver, unscrew the screw locking the protection guard of the motor's terminal board.



Using socket wrench size 8, disconnect the 3 wires (black-blue-brown) coming from the electric power supply cable from the motor's terminal board.

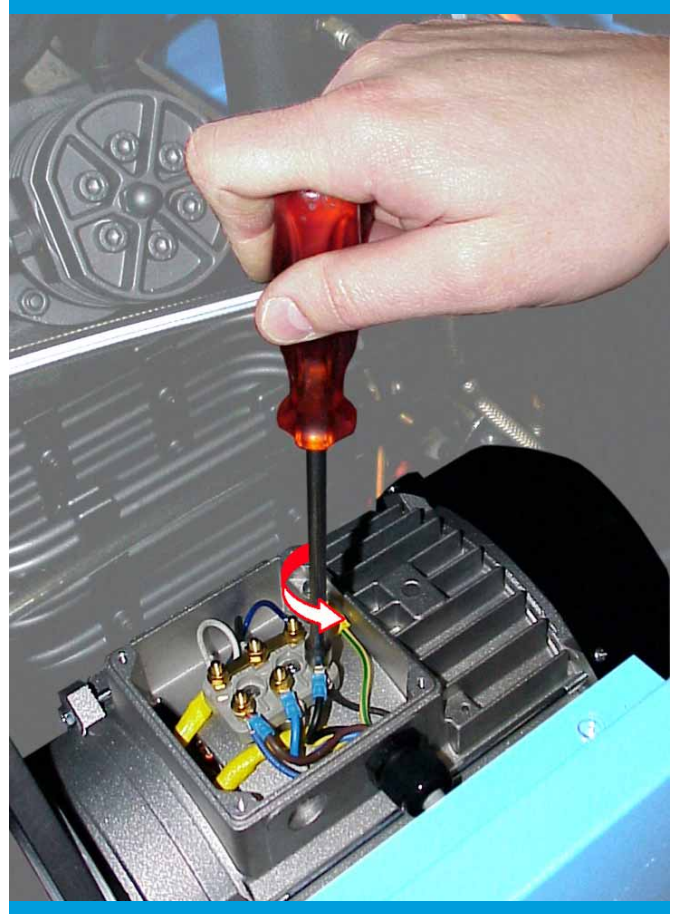

Using the Philips screwdriver, unscrew the screw locking the grounding wire (yellow - green).

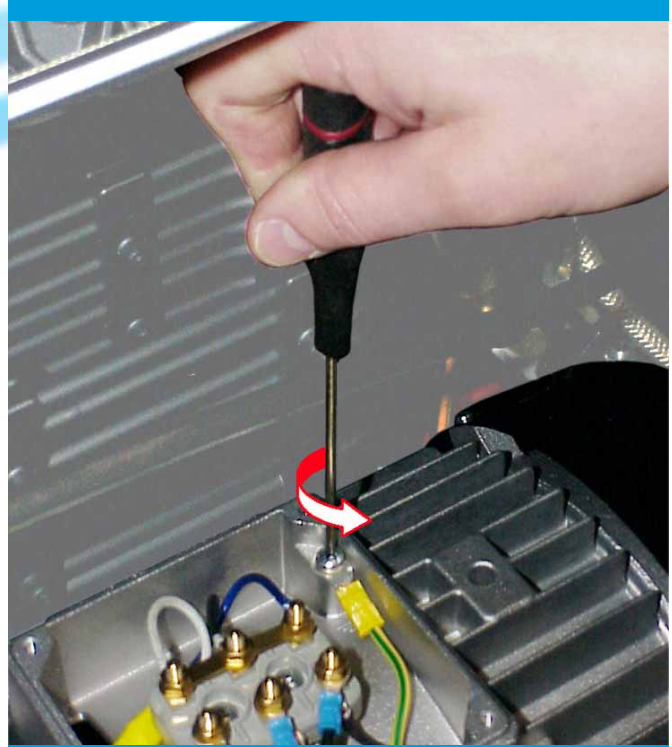

Using round-nose pliers loosen the wire clamp found on the motor's terminal board box and pull the electric cable out completely.

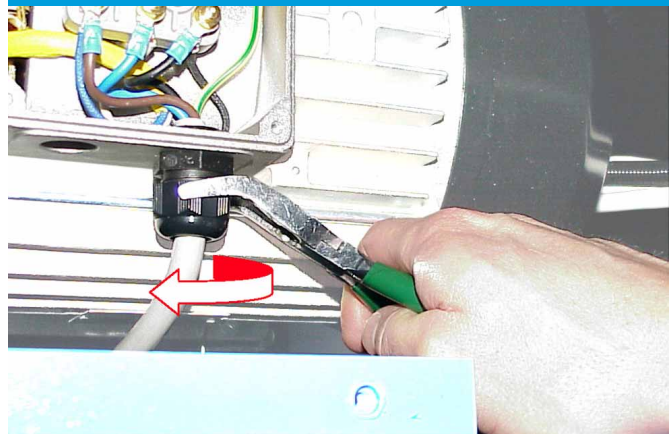

Disconnect the third stage pressure gauge tube, using wrench size 14.

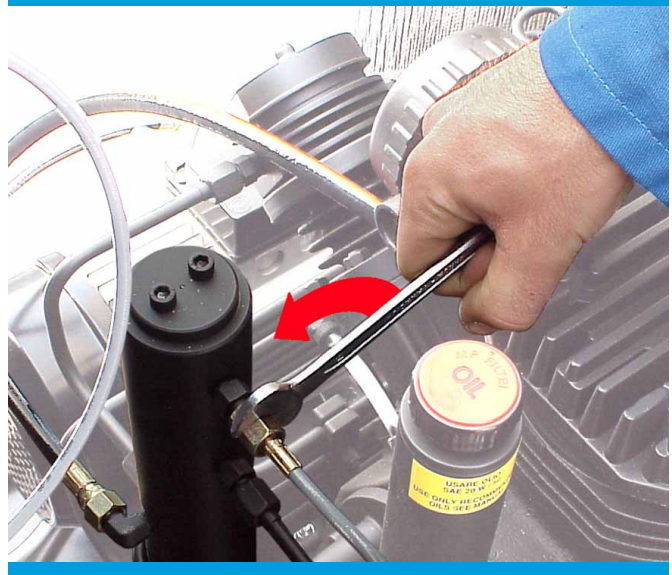

Disconnect the hose from the maintenance valve fitting using wrench size 17 (14 and 15 for earlier versions).

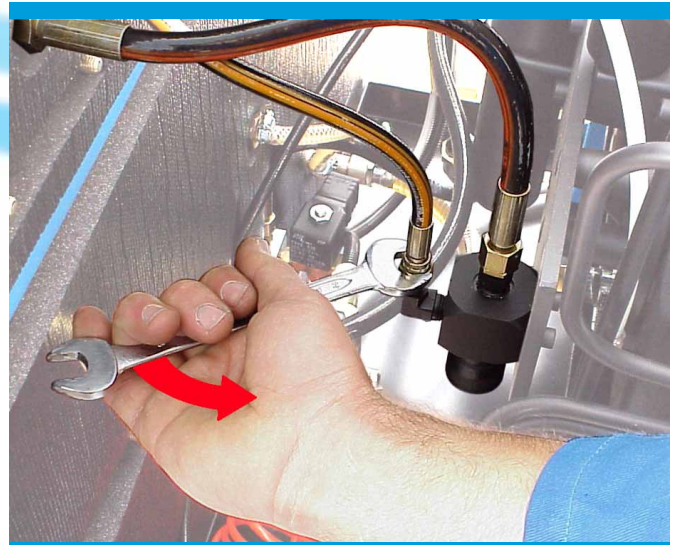

Using wrench size 17 disconnect the hose connecting the filter to the pressure maintenance valve.

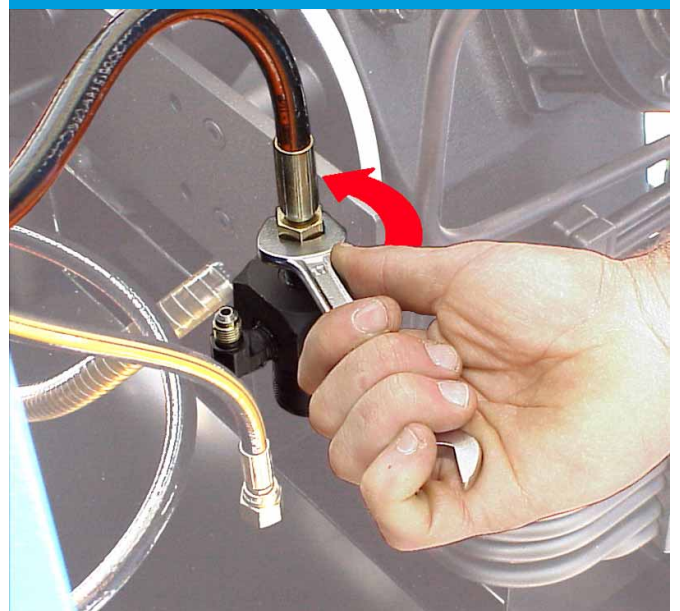

Before dismantling the front panel discharge the oil by unscrewing the discharge tap using wrench size 24.



S U P E R  
S I L E N T

Use a suitable container to collect the oil.

Do not discharge the oil in the gutter or in the drain.

**Do not discharge the oil in the gutter or in the drain.**

Disconnect the tube connected to the oil discharge fitting by unscrewing the metal clamp using the Flat screwdriver.

Using wrench size 14 disconnect the white discharge plastic tube from the crankcase.

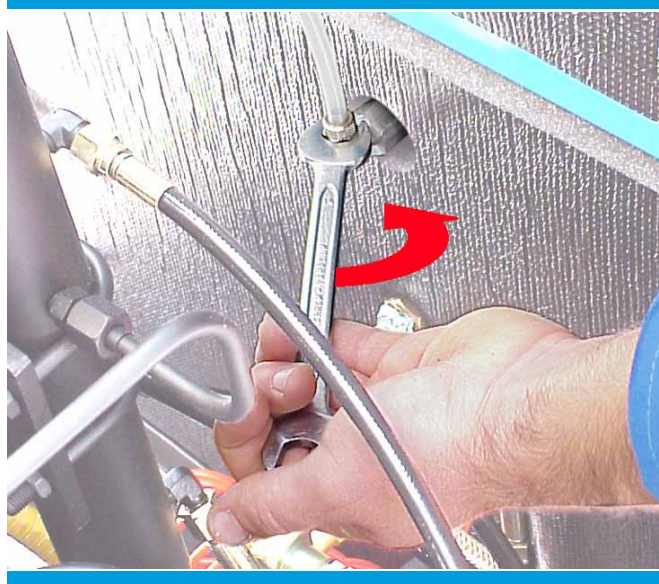
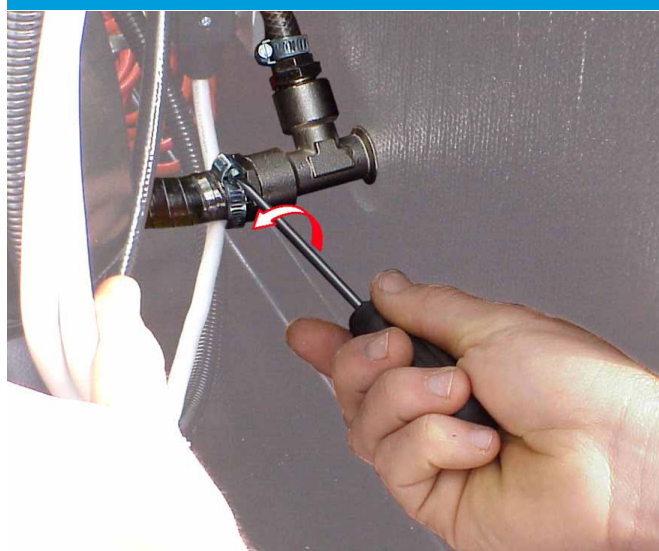
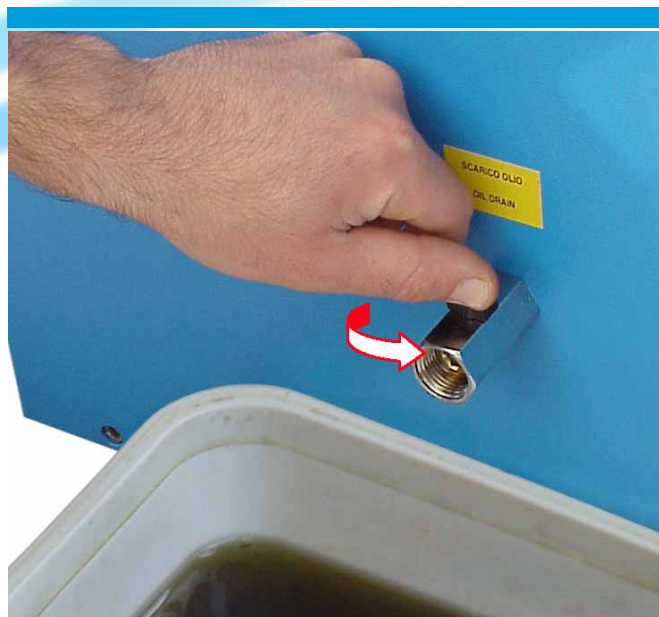

Using wrench size 17 (14 and 15 for earlier versions) disconnect the hose connecting the bottom condensate separator to the electric valve block.

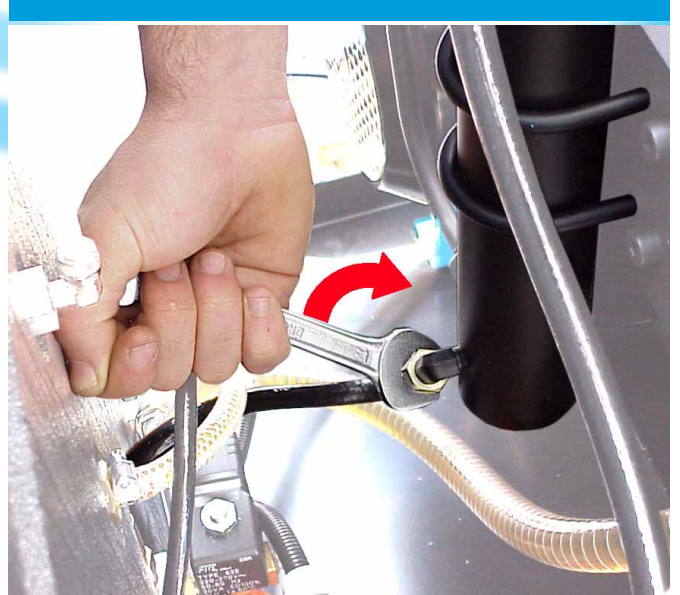

Remove the front panel by unscrewing the 2 Allen screws locking the frame using Allen spanner size 5.

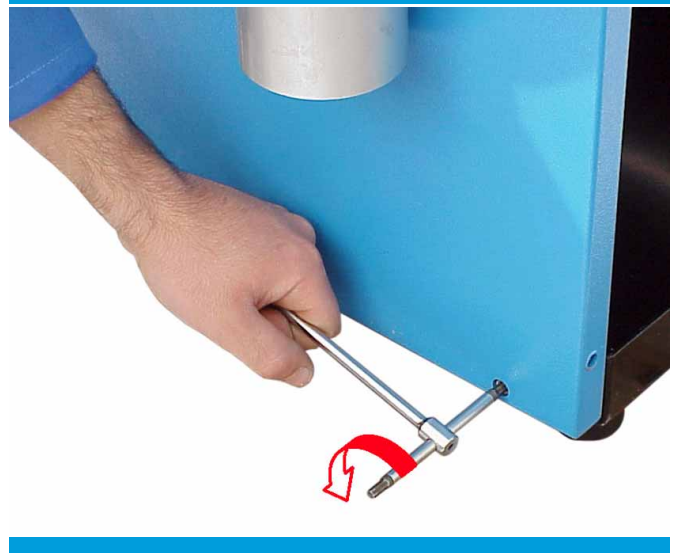









S U P E R  
S I L E N T

**COMPRESSOR “MINI SILENT” MODEL PANELS AND FRAMES**

<b>LEVEL OF SERVICING DIFFICULTY</b>	SIMPLE	MEDIUM 	DIFFICULT
--------------------------------------	--------	-----------------------------------------------------------------------------------------------	-----------

**EXPECTED TIME NEEDED : 70 minutes**

**TOOLS NEEDED**

 Wrench size 10	 Wrench size 14-15	 Wrench size 17	 Wrench size 24	 Socket wrench size 8
 Allen spanner size 5	 Round-nose pliers	 Flat screwdriver	 Philips screwdriver	

**SPECIAL TOOLS**

 Valve key			
--------------------------------------------------------------------------------------------------	--	--	--

## 1.5 MINI SILENT

**NOTE:** Before disconnecting the hoses, mark each one with a label, in order to make re-assembly operations simpler.

Remove the back conveyor by lifting it.



Unscrew the 4 top cap nuts using key size 10 and remove the top conveyor and the cover.



Using the Allen spanner size 5 unscrew the 4 screws and remove the 4 lateral protection panels.

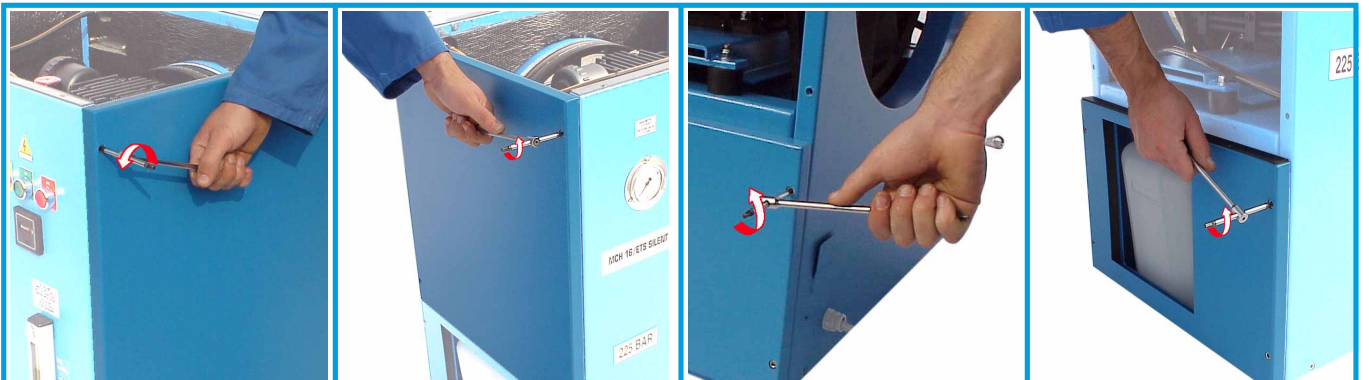

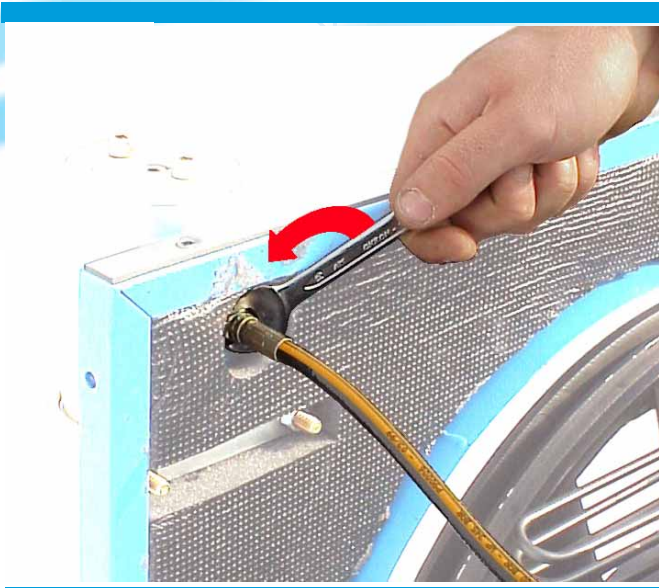

Using wrench size 17 (14 and 15 for earlier versions) disconnect the 3 hoses from the fittings found on the filter (internal side of the back panel); the hose fitting found lower down must be unscrewed from the outside.

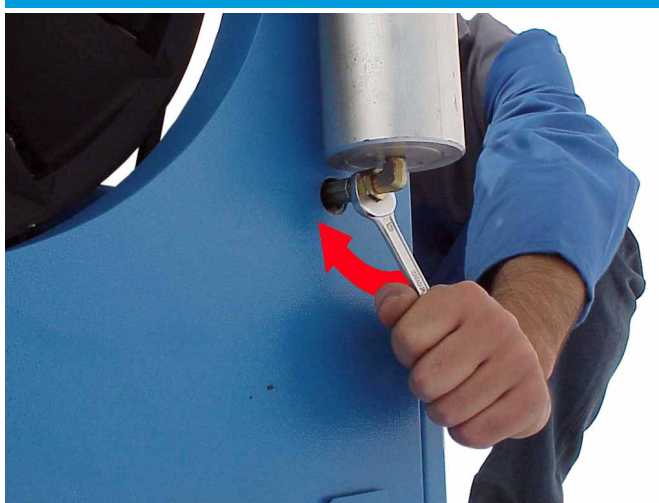

Unscrew the Allen screws locking the back protection panel and remove it using the Allen spanner size 5.



Before removing the front panel the following operations must be carried out:

disconnect the electric power supply cable from the plug by unscrewing the wires from the internal terminal board.



Using round-nose pliers loosen the wire clamp found on the back panel and pull the electric cable out completely.

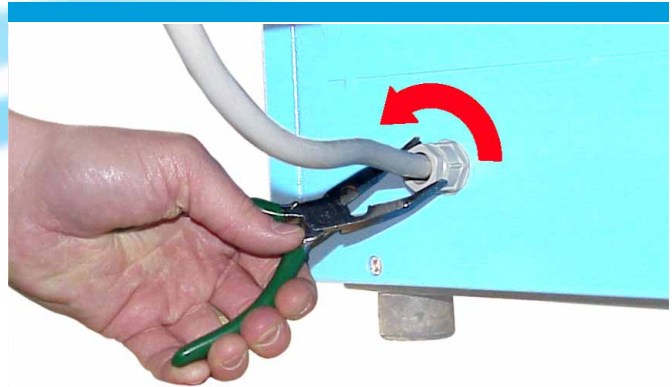

Using the special key supplied (cod. SC 000-490) unscrew the HP condensate discharge electric valve nut (cod. 13-04-0222) and remove the coil.



Using the Philips screwdriver, unscrew the screw locking the fitting to the LP condensate discharge electric valve (cod.13-04-0221) and unhook the fitting taking care with its gasket.

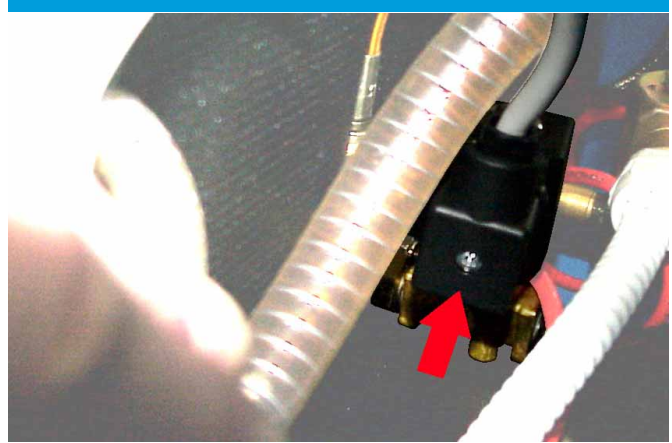

Using the Philips screwdriver, unscrew the screw locking the fitting to pressure switch (cod. SC000310 for 280 bar and cod. SC000315 for 330 bar) and unhook the fitting taking care with its gasket.



Using wrench size 10, unscrew the nuts locking the cover of the push-button panel in order to access its internal front panel.

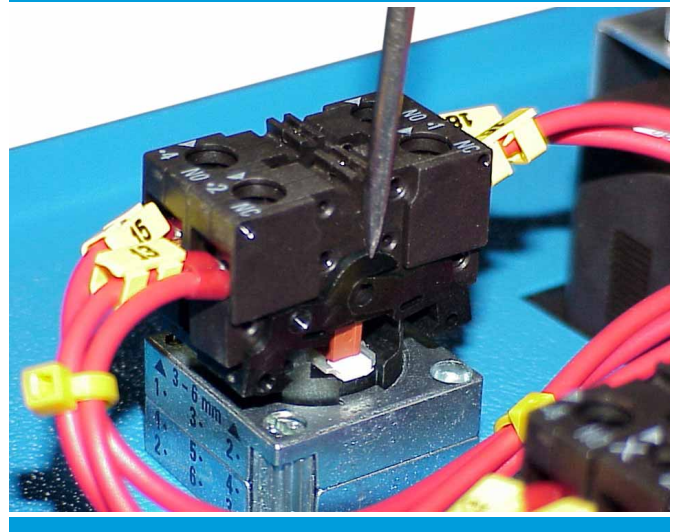
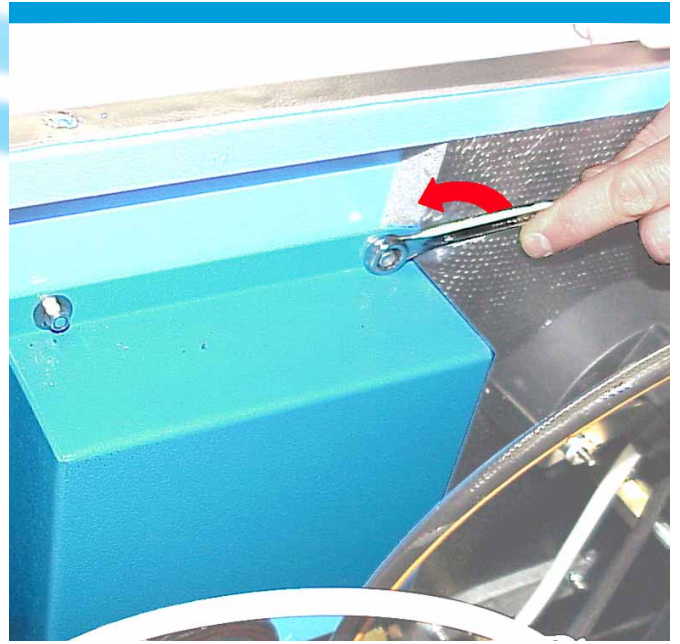

Unhook the rapid clamps found on each button as shown in the picture opposite.

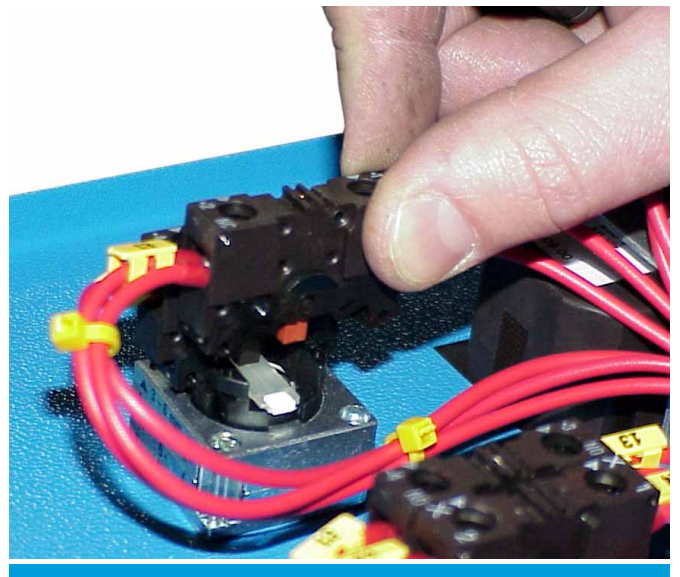

Using the Flat screwdriver disconnect the meter's power supply wires.



Disconnect the third stage pressure gauge tube using wrench size 14.



Disconnect the hose from the fitting maintenance valve using wrench size 17 (14 and 15 for earlier versions).

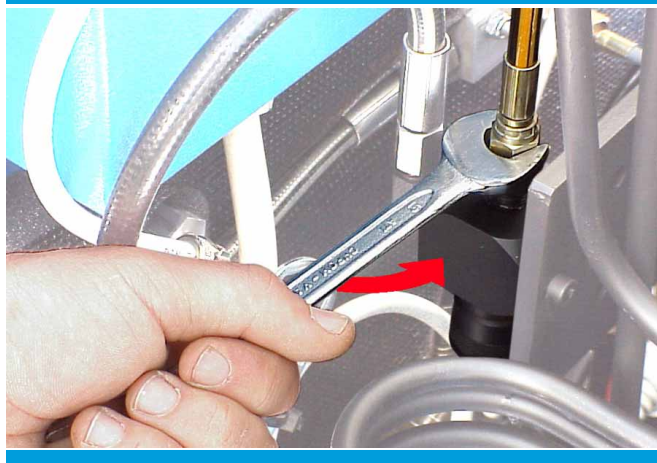

Using wrench size 17 (14 and 15 for earlier versions) disconnect the hose connecting the filter to the pressure maintenance valve.



Before dismantling the front panel discharge the oil by unscrewing the discharge cover with wrench size 24. Use a suitable container for the oil.

**Do not discharge the oil in the gutter or in the drain.**



Next open the appropriate tap.



Disconnect the tube connecting the oil discharge fitting by unscrewing the metal clamp with the Flat screwdriver.

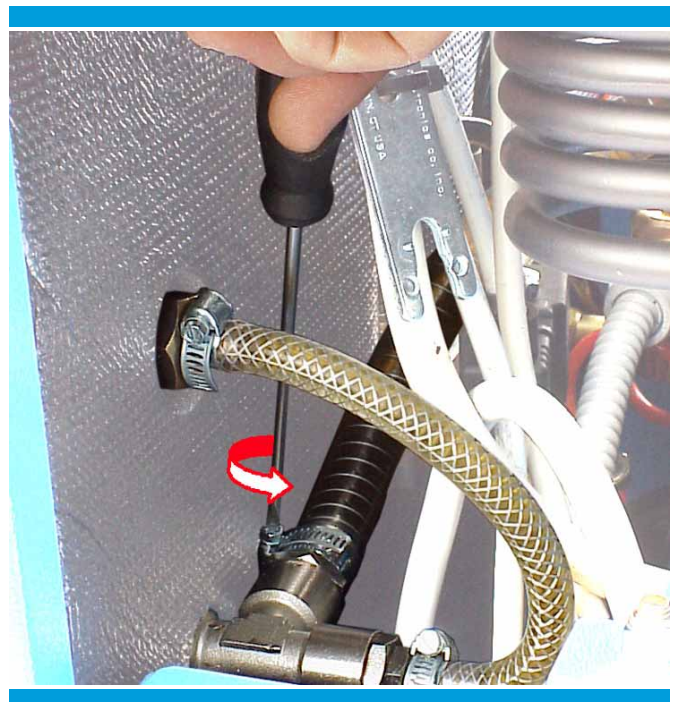

Using wrench size 14 disconnect the white plastic discharge tube of the crankcase.

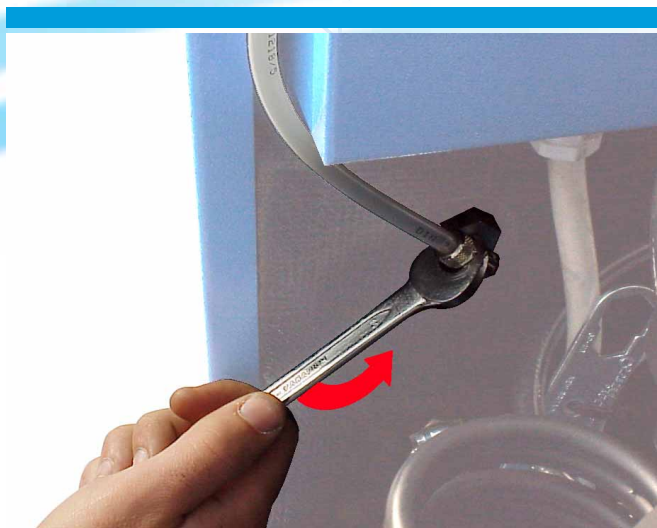

Using the Allen spanner size 5 remove the front panel by unscrewing the Allen screws locking it to the frame.



With wrench size 17 (14 and 15 for earlier versions) disconnect the hoses connecting the bottom condensate separator with the electric valve block.

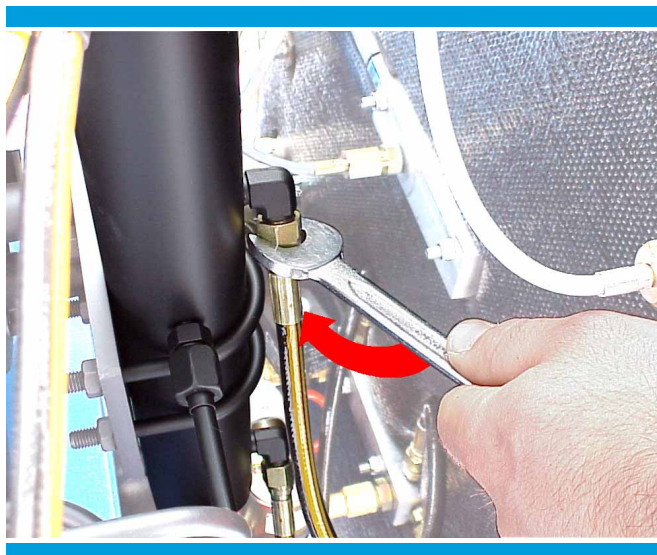

**COMPRESSOR "OPEN" MODEL PANELS AND FRAMES**

<b>LEVEL OF SERVICING DIFFICULTY</b>	SIMPLE ●	MEDIUM	DIFFICULT
--------------------------------------	-------------	--------	-----------

**EXPECTED TIME NEEDED : 30 minutes**

**TOOLS NEEDED**

 Wrench size 10	 Wrench size 14-15	 Wrench size 17	 Allen spanner size 5	 Socket wrench size 8
 Flat screwdriver		 Philips screwdriver		 Round-nose pliers

**SPECIAL TOOLS**

 Valve key			
--------------------------------------------------------------------------------------------------	--	--	--

## 1.6 OPEN

**NOTE:** Before disconnecting the hoses, mark each one with a label, in order to make re-assembly operations simpler.

Using the Allen spanner size 5 unscrew the 2 Allen screws and remove the top panel.

With the help of the Allen spanner size 5 unscrew the 4 screws locking the left side panel and remove it.



Disconnect the 3 condensate discharge hoses coming from the aluminium condensate discharge block (with electric valves) using wrench size 17 (14 and 15 for earlier versions).

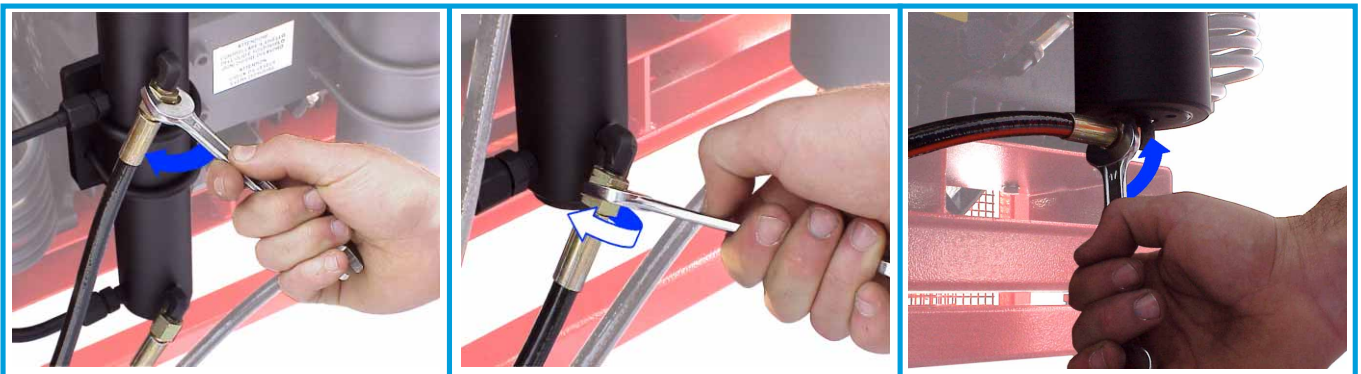

Using the Philips screwdriver, unscrew the screw locking the fitting to the LP condensate discharge electric valve (cod. 13-04-0221) and unhook the fitting taking care with its gasket.

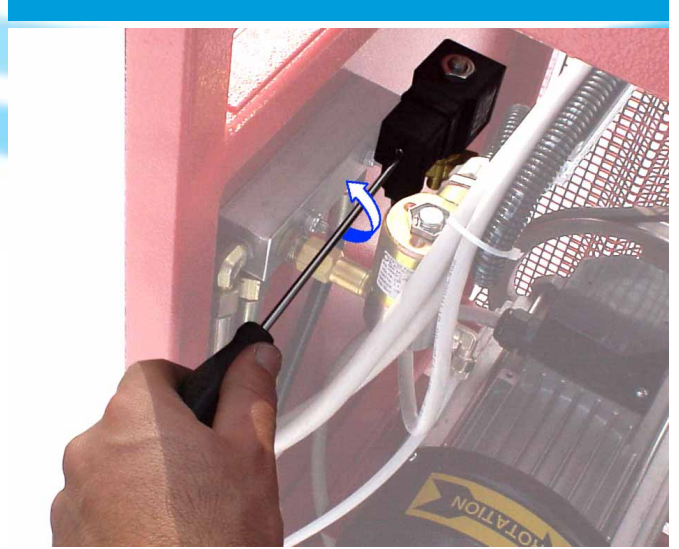

Using the special key supplied (cod. SC000490) unscrew the HP condensate discharge electric valve nut (cod.13-04-0222) and remove the coil.

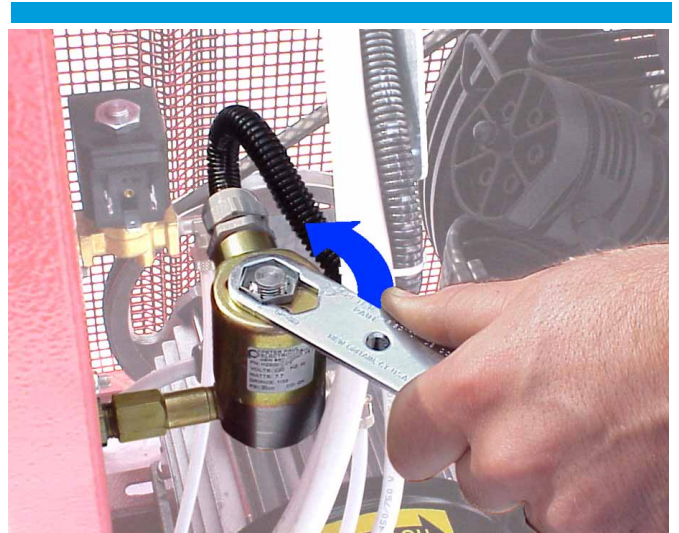

Using the Philips screwdriver, unscrew the screw blocking the fitting to the pressure switch (cod. SC000310 for 280 bar and cod. SC000315 for 330 bar) and unhook the fitting taking care with its gasket.



Using Allen spanner size 5 unscrew the screws locking the right side panel and remove it.



Unscrew the Allen screws and remove the front grating panel.



Using the Philips screwdriver, unscrew the screws locking the protection guard of the motor's terminal board.



Using socket wrench size 8, disconnect the 3 wires (black-blue-brown) coming from the electric power supply cable of the motor's terminal board.

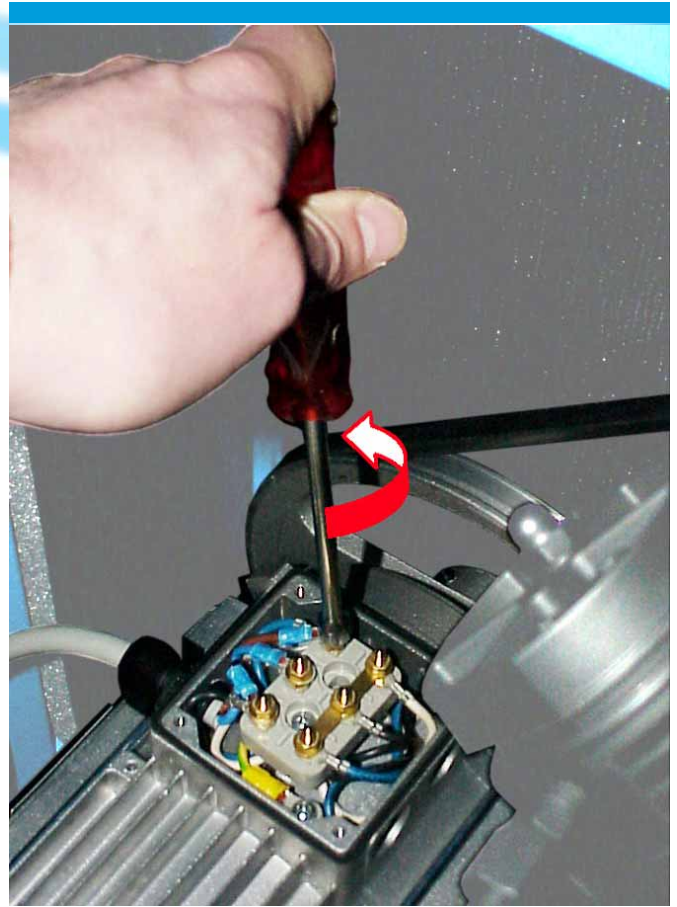

Using the Philips screwdriver, unscrew the screw locking the grounding wire (green-yellow) from the motor's terminal board.

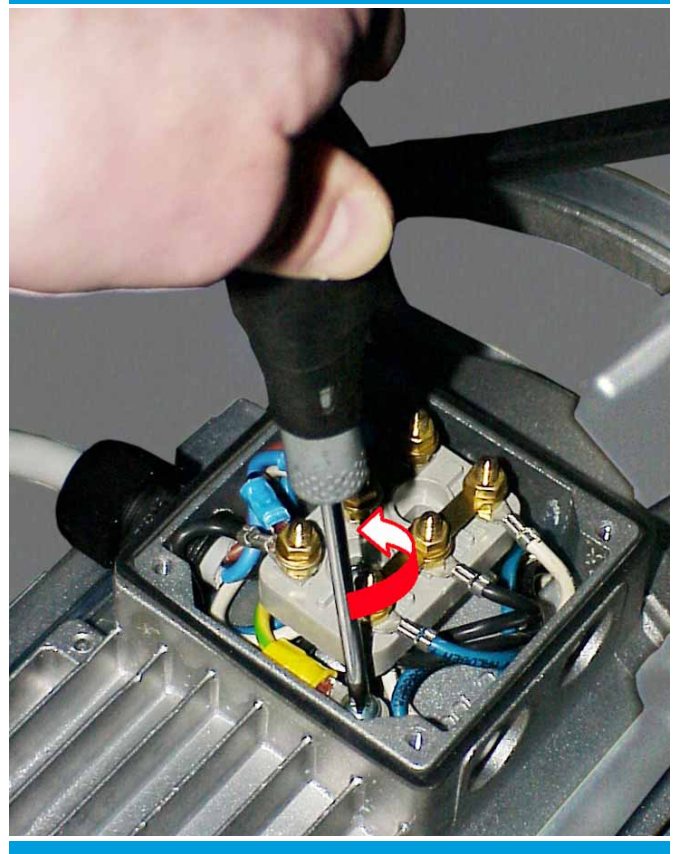

Using round-nose pliers, loosen the wire clamp found on the motor's terminal board box and pull the power supply cable out completely.

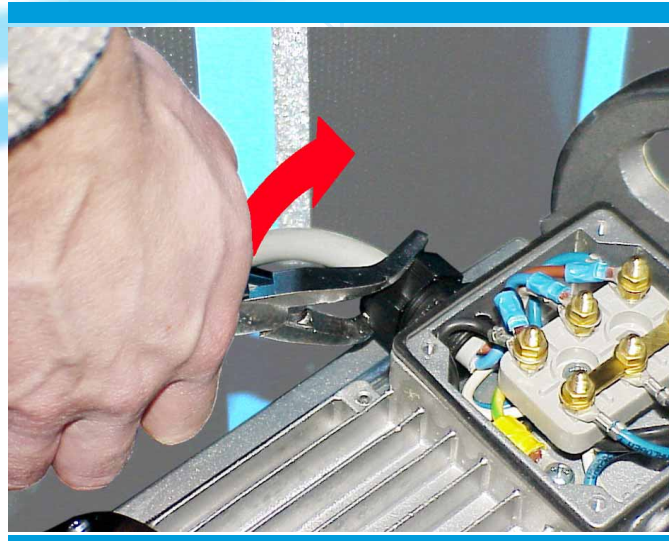

Disconnect the hose connecting the pressure maintenance valve to the instruments' panel using wrench size 17 (14 and 15 for earlier versions).

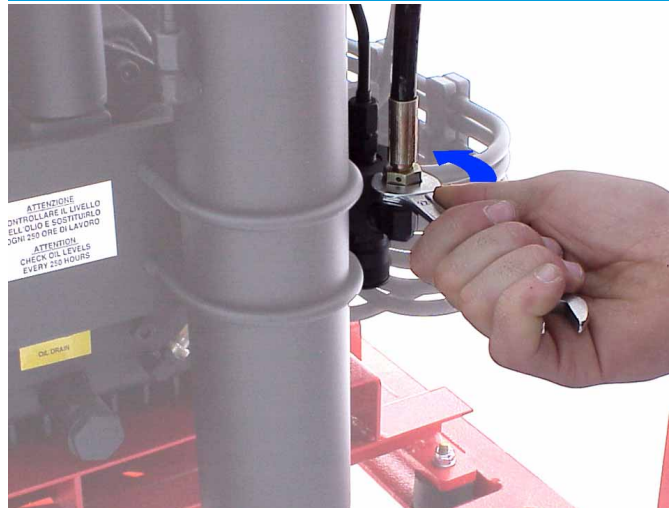

Using the Allen spanner size 5 unscrew the 4 Allen screws and remove the top panel (with instruments).











**SECOND STAGE AIR INTAKE AND DISCHARGE VALVES**



<b>LEVEL OF SERVICING DIFFICULTY</b>	SIMPLE ●	MEDIUM	DIFFICULT
--------------------------------------	-------------	--------	-----------

**EXPECTED TIME NEEDED : 15 minutes**

**TOOLS NEEDED**

 Wrench size 10	 Wrench size 19	 Wrench size 32	 Allen spanner size 5	 Allen spanner size 6
 Vise	 Hammer	 Round-nose pliers		

**SPECIAL TOOLS**

 Special key for valves	 Graver		
---------------------------------------------------------------------------------------------------------------	-----------------------------------------------------------------------------------------------	--	--

## 2 PUMP UNIT

### 2.1 SECOND STAGE AIR INTAKE AND DISCHARGE VALVES

Air intake valve (cod. 13-02-0044).



Discharge valve (cod. 13-02-0049).



#### 2.1.1 SECOND STAGE HEAD DISMANTLEMENT

Using wrench size 19 unscrew the 2 fittings of the cooling pipes found on the second stage head on the air intake and discharge side.

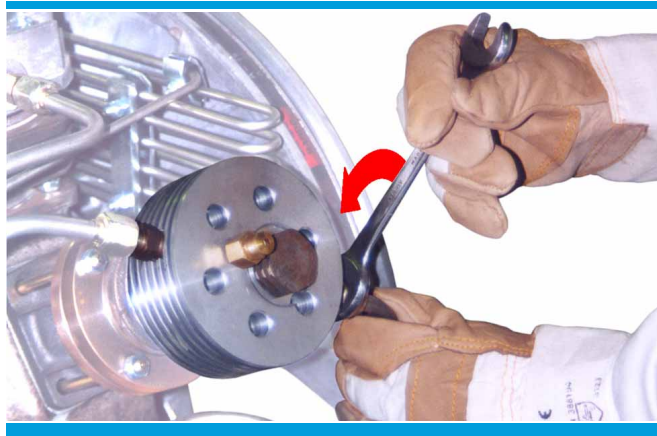

Unscrew the 6 Allen screws locking the second stage head (cod. 13-01-0046) to its cylinder (cod. 13-02-0043 for MCH13 and cod. 16-02-0043 for MVH16), using the Allen key size 6.

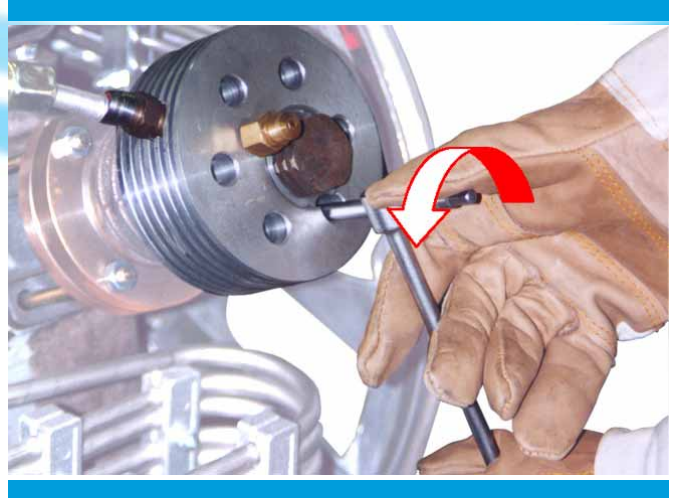

### 2.1.2 INTAKE VALVE DISMANTLEMENT

After having removed the second stage head, clamp it in a vise, inserting 2 of the 6 Allen screws formerly removed in order to clamp the head in the vise without damaging it (see figure opposite).

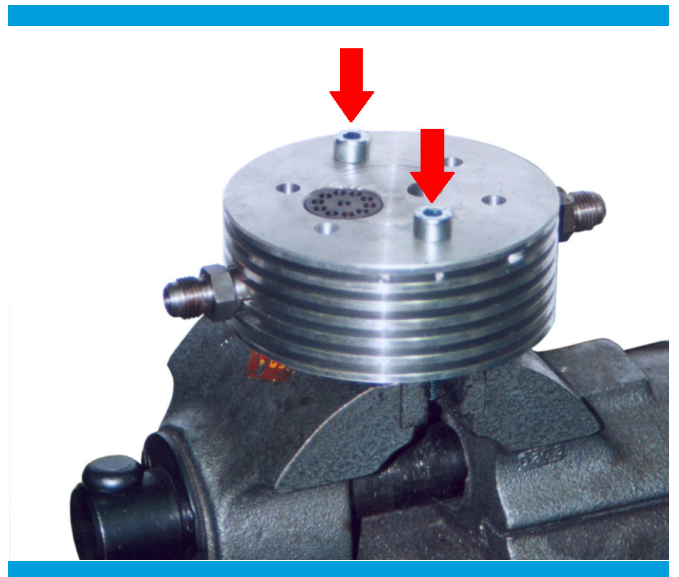

Using the special valve pin key supplied (cod. SC000480), unscrew the second stage intake valve (cod. 13-02-0044).

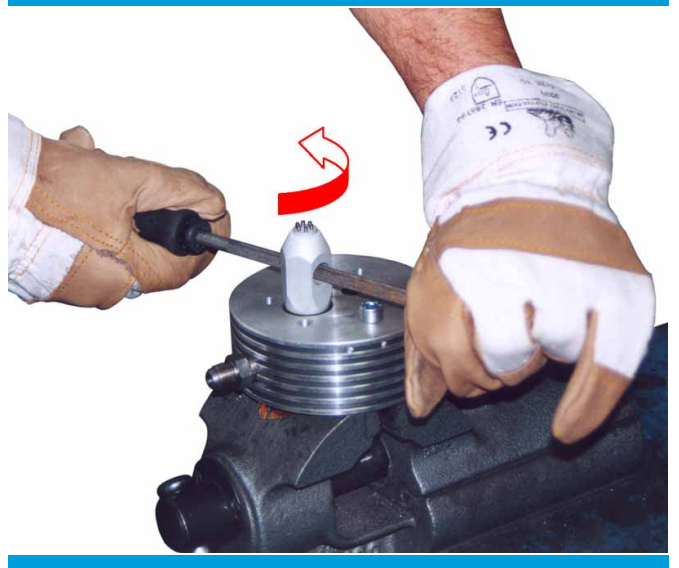

PUMP UNIT

Using the special valve pin key supplied (cod. SC000480), unscrew the second stage intake valve (cod. 13-02-0044).

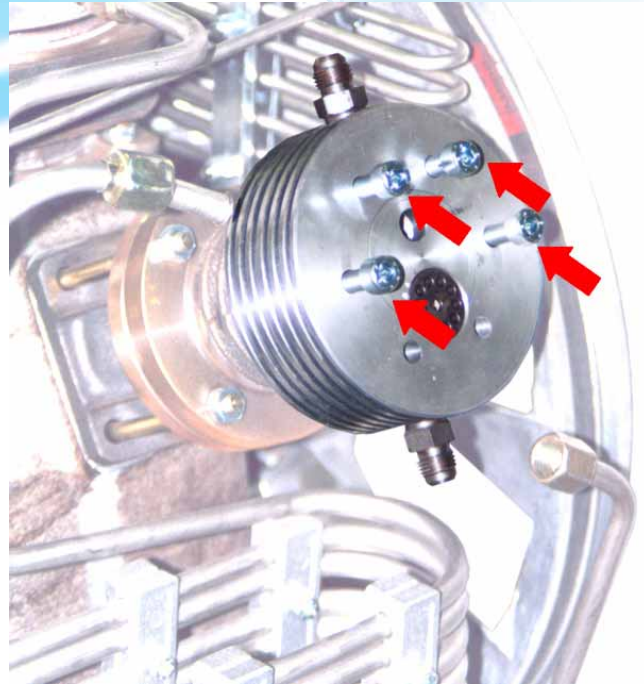

Lubricate the thread of the intake valve with medium density grease. Should it be damaged replace even the second stage copper gasket (cod. 13-02-0051).

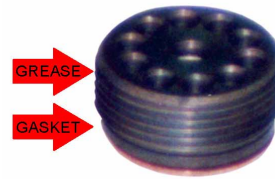

Clamp the air intake valve found under the second stage head with force.

In order to avoid the valve unscrewing after the first hours of operation, before assembling the second stage head dimple must be made near the intake valve using a hammer and a punch.



### 2.1.3 SECOND STAGE DISCHARGE VALVE DISMANTLEMENT

After having removed the second stage head, clamp it in a vise by inserting 2 of the 6 Allen screws formerly removed in order to block the head in the vise without damaging it (see figure opposite).

Using wrench (or Allen key) size 32, unscrew the discharge valve (cod. 13-02-0049).

**NOTE: THE DISCHARGE VALVE CAN BE  
DISMANTLED WITHOUT REMOVING THE  
COMPRESSOR'S SECOND STAGE HEAD.**

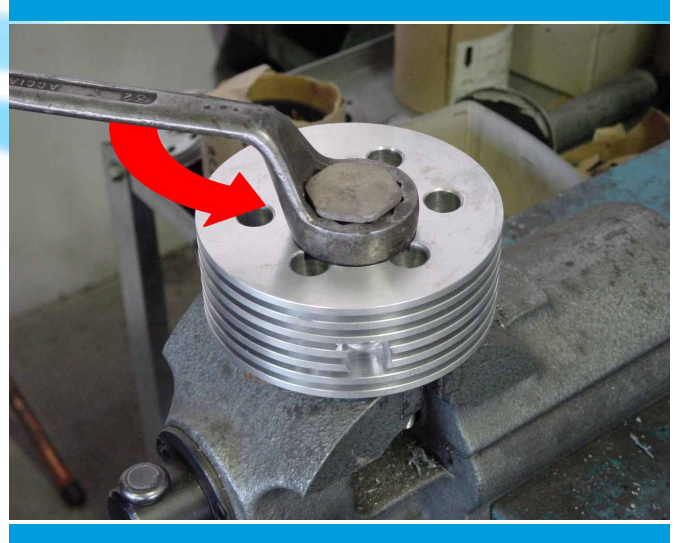

Lubricate the thread of the discharge valve with medium density grease. Should it be damaged replace even the o-ring (cod. 13-02-0056) and the second stage copper gasket (cod. 13-02-0051).











**THIRD STAGE AIR INTAKE AND DISCHARGE VALVES**



<b>LEVEL OF SERVICING DIFFICULTY</b>	SIMPLE	MEDIUM 	DIFFICULT
--------------------------------------	--------	-----------------------------------------------------------------------------------------------	-----------

**EXPECTED TIME NEEDED : 20 minutes**

**TOOLS NEEDED**

 Wrench size 13	 Wrench size 14-15	 Wrench size 19	 Allen spanner size 5	 Allen spanner size 6
 Vise	 Hammer	 Round-nose pliers		

**SPECIAL TOOLS**

 Special key for valves	 Graver		
---------------------------------------------------------------------------------------------------------------	-----------------------------------------------------------------------------------------------	--	--

## 2.3 THIRD STAGE AIR INTAKE AND DISCHARGE VALVES

Air intake valve (cod. 13-03-0020).

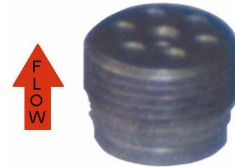

Discharge valve (cod. 13-03-0028).



These valves must be replaced when they are not airtight anymore.

### THIRD STAGE DISCHARGE VALVE DISMANTLEMENT

In order to carry out this operation the third stage head must be dismantled (cod. 13-03-0027).

Unscrew the cooling pipe fittings on the third stage head using wrench size 19 for the intake side and size 14 for the discharge side.

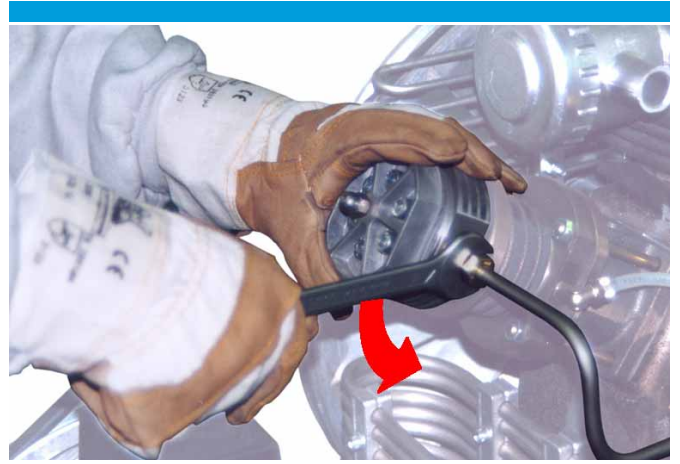

Unscrew the cap nut (cod. 13-00-0032) found on the cover (cod. 13-03-0030) of the third stage head (cod. 13-03-0027) using wrench size 13.



Unscrew the 6 Allen screws (cod. 13-00-0031) locking the cover (cod. 13-03-0030) and third stage head (cod. 13-03-0027) to its cylinder using Allen key size 6.



After having removed the third stage head, unhook its top cover.



Remove the discharge valve (cod. 13-03-0028) using pliers.

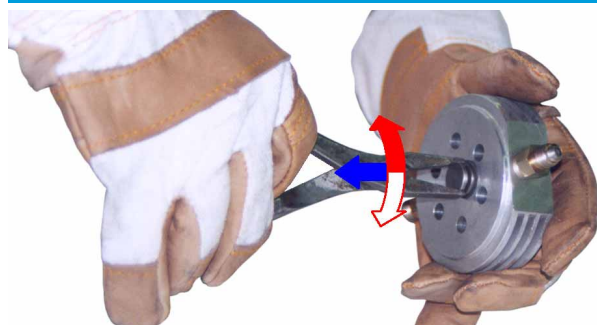

Should it be impossible to remove it this way, try inserting a pin in the small pre-set hole on the head (opposite side of the valve) and push out the valve with small hammer strokes.



### ASSEMBLY OF THE THIRD STAGE DISCHARGE VALVE

Replace the O-ring gasket (cod. 13-03-0029) before mounting the discharge valve.



Insert a new third stage discharge valve (cod. 13-03-0028) complete of O-ring gasket (cod. 13-03-0029) in its seat on the head.

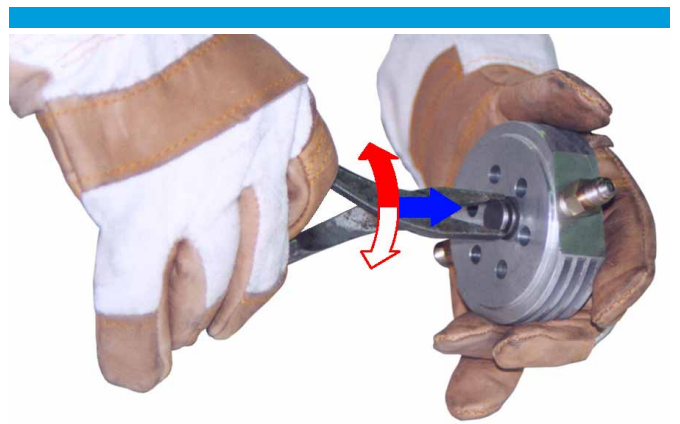

Set the cover (cod. 13-03-0030) on the third stage head and block the entire group again onto the third stage guiding cylinder (cod. 13-02-0017) using the 6 Allen screws (cod. 13-00-0031), with the Allen key size 6. Note that the maximum driving torque is 2,5 Kpm.



Screw the stainless steel headless Allen screw by hand onto the cover (cod. 13-03-0034); replace also the copper sealing washer (cod. 13-03-0033). Seat the stainless steel nut (cod. 13-00-0032) in position and tighten using wrench size 13.

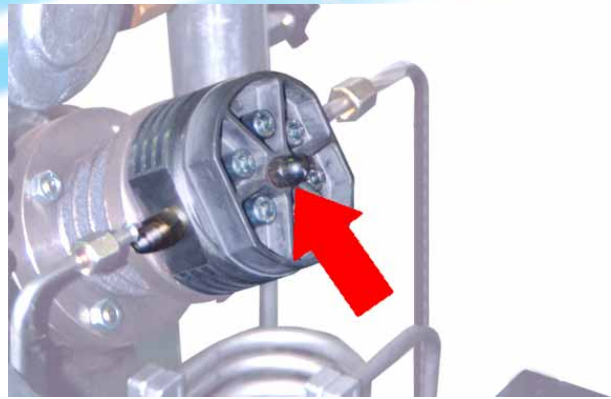

### THIRD STAGE INTAKE VALVE DISMANTLEMENT

The third stage head (cod. 13-03-0027) must be dismantled to carry out this operation.

Unscrew the cooling pipes fittings found on the third stage head using wrench size 19 for the intake side and size 14 for the discharge side.

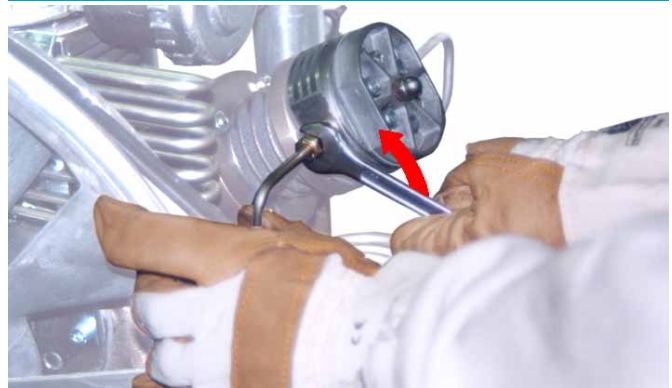

Unscrew cap nut (cod. 13-00-0032) found on the cover (cod. 13-03-0030) of the third stage head (cod. 13-03-0027) using wrench size 13.



Unscrew the 6 Allen screws (cod. 13-00-0031) locking the cover (cod. 13-03-0030) and third stage head (cod. 13-03-0027) to its cylinder using Allen key size 6.

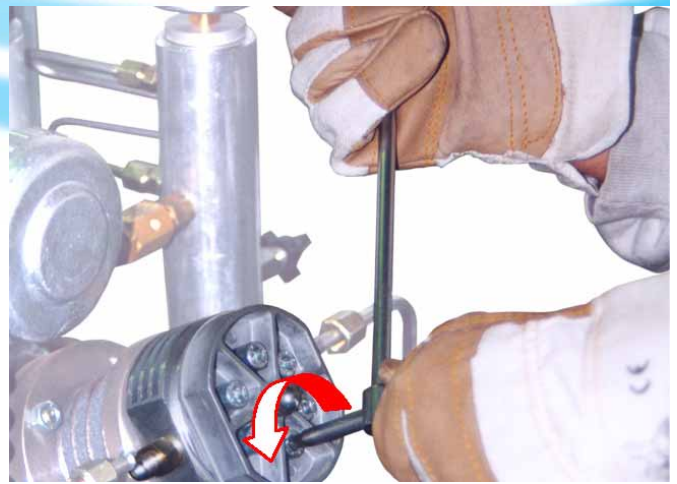

After having removed the third stage head, take its top cover off.



Lock the third stage head (cod. 13-03-0027) in a vise, by inserting 2 of the 6 Allen screws formerly removed in order to clamp the head in the vise without damaging it.

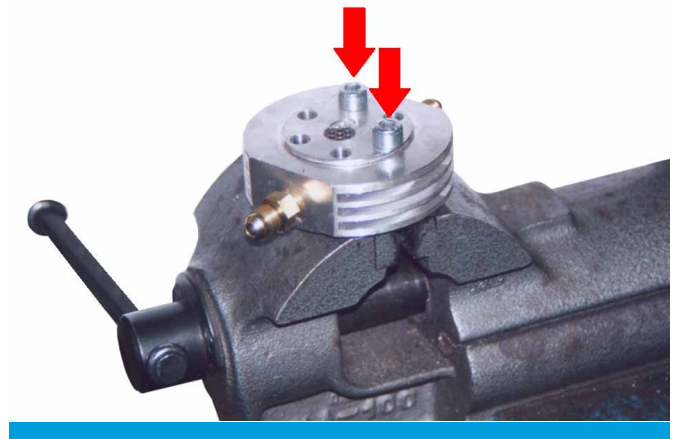

**NOTE:** If a vise is not available, the second stage head must be turned upside down by 180° and bolted to its third stage cylinder (cod. 13-02-0017) with only 2 screws using a size 6 key.

Do NOT tighten the screws with force. In this case also the discharge valve (cod. 13-03-0028) must be removed as described in the relevant chapter.

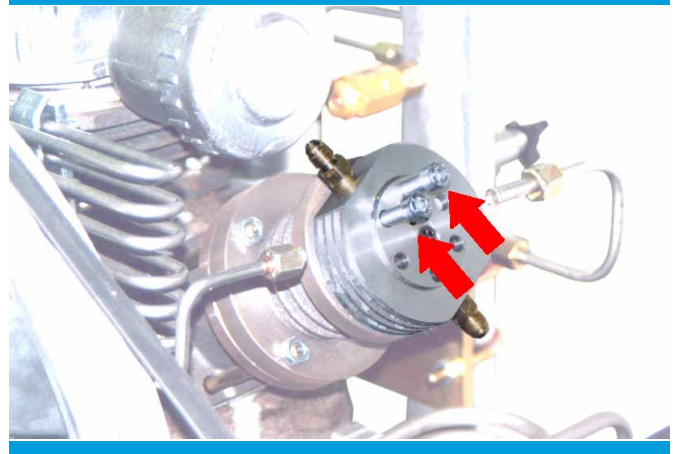

Unscrew the air intake valve using the special key supplied (cod. SC000480).



### THIRD STAGE AIR INTAKE VALVE RE-ASSEMBLY

Lubricate the thread of the air intake valve (cod. 13-03-0020) with medium density grease.

Lock the air intake valve under the third stage head using the special key supplied (cod. SC000480).

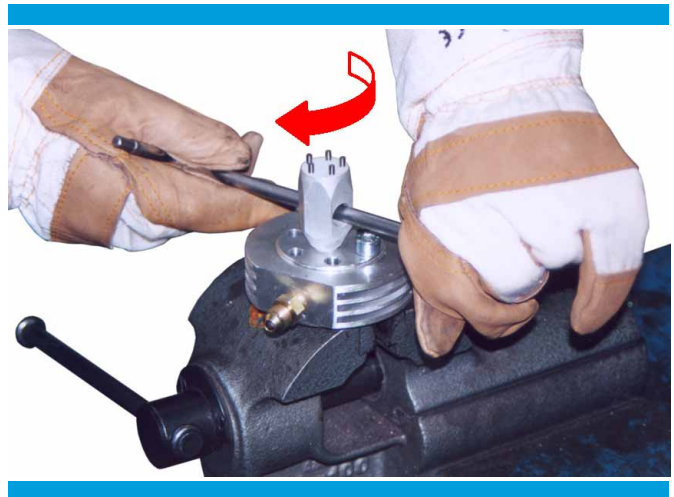

Before re-assembling the third stage head dimple must be done near the intake valve using a hammer and a graver, in order to avoid the valve unscrewing after the first hours of operation.

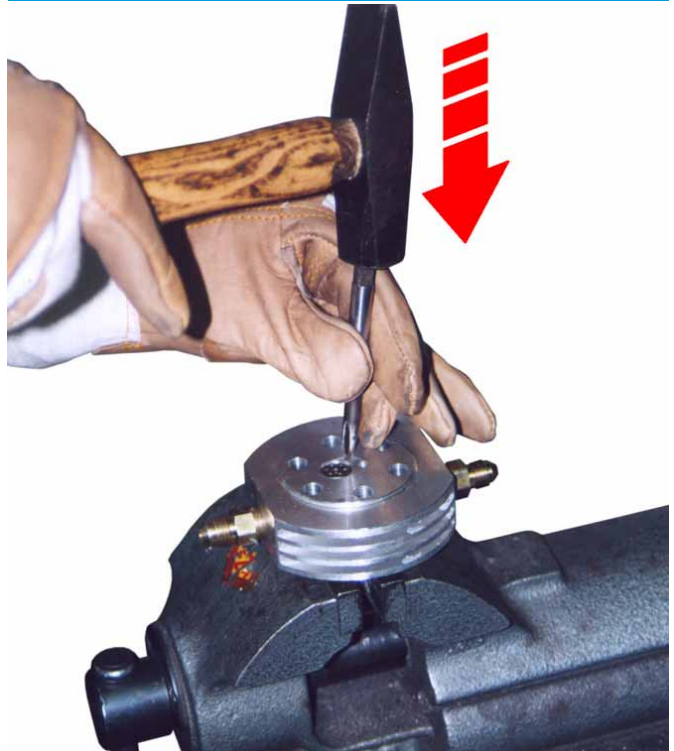

Set the cover (cod. 13-03-0030) on the third stage head and lock the entire group again onto the third stage guiding cylinder (cod. 13-02-0017) using the 6 Allen screws, with the Allen key size 6. Note that the maximum driving torque is 2,5 Kpm.

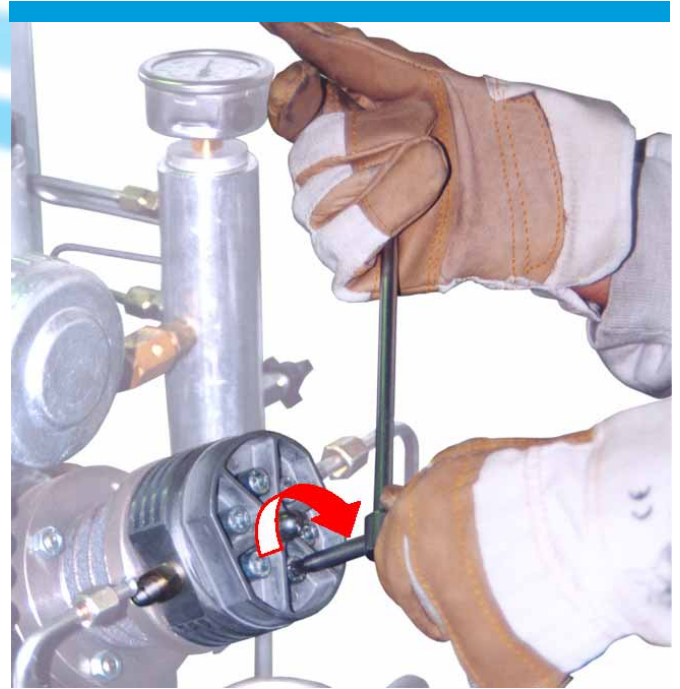

Screw the stainless steel headless Allen set screw by hand onto the cover (cod. 13-03-0034); replace also the copper sealing washer (cod. 13-03-0033). Seat the stainless steel nut (cod. 13-00-0032) in position and tighten using wrench size 13.

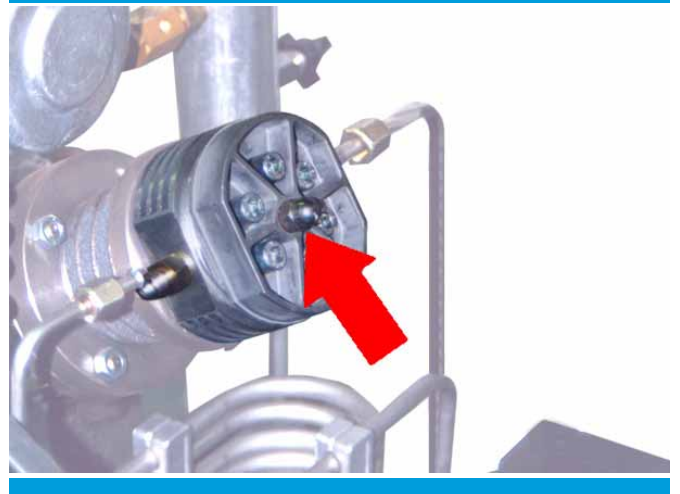

PUMP UNIT

**FIRST STAGE INTAKE AND DISCHARGE VALVE HEAD (LAMELLAR VALVE)**

<b>LEVEL OF SERVICING DIFFICULTY</b>	SIMPLE	MEDIUM ● ●	DIFFICULT
--------------------------------------	--------	---------------	-----------

**EXPECTED TIME NEEDED FOR DISMANTLEMENT AND ASSEMBLY : 30 minutes**

**TOOLS NEEDED**

 Wrench size 10	 Wrench size 19	 Allen key size 5	 Allen key size 6	 Vise
 Mallet				

**SPECIAL TOOLS**

--	--	--	--

## 2.1 FIRST STAGE INTAKE AND DISCHARGE VALVE HEAD (LAMELLAR VALVE)

First stage head with valves (cod. 13-01-0004).

This is a compact lamellar valve, and, if necessary (e.g. in case of loss), can be replaced solely as a complete unit.

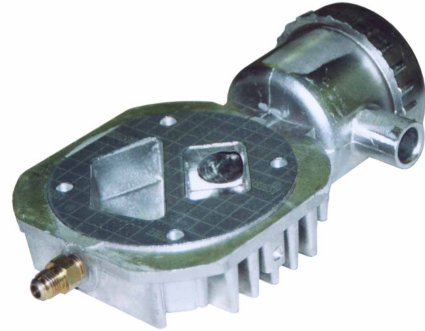

### FIRST STAGE VALVE DISMANTLEMENT

The first stage head cover (cod. 13-01-0006) must be dismantled before carrying out this operation.

Unscrew the cooling pipe fitting (cod. 13-00-0085) from the first stage head using wrench size 19.

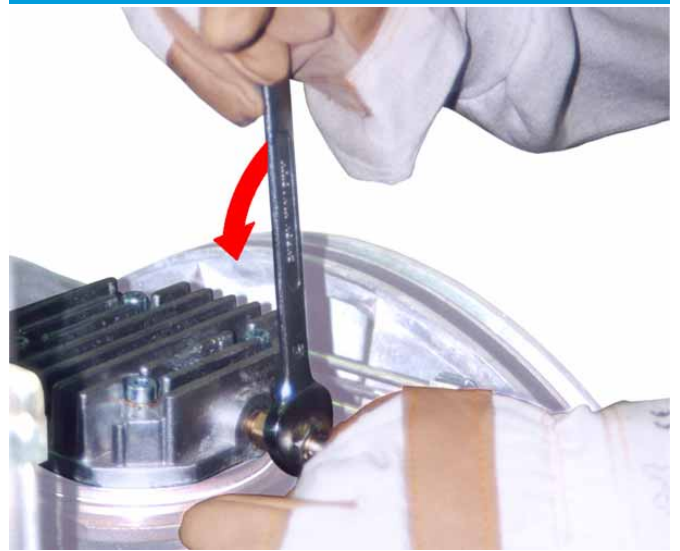

Unscrew the 4 Allen screws (cod. 13-00-0010) locking the first stage head cover (cod. 13-01-0006) to its cylinder using Allen key size 6.



PUMP UNIT

Remove the head; should it appear stuck to the cylinder give small mallet (in rubber or wood in order to avoid damages) strokes on the head sides.

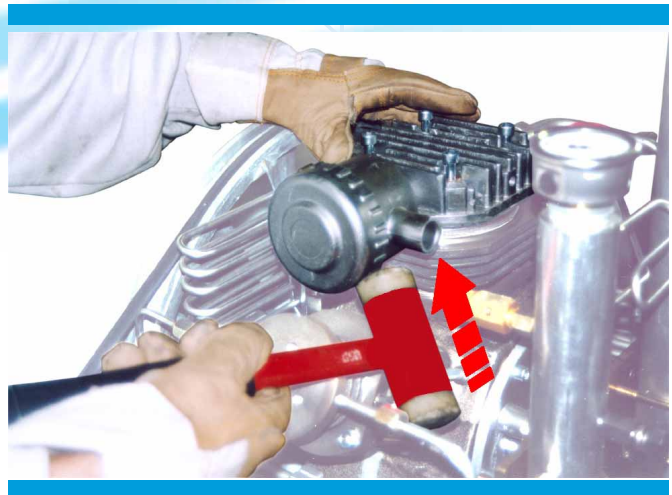

Using a screwdriver as lever, detach the lamellar valve (cod. 13-01-0004) (intake and discharge) from the first stage head cover.

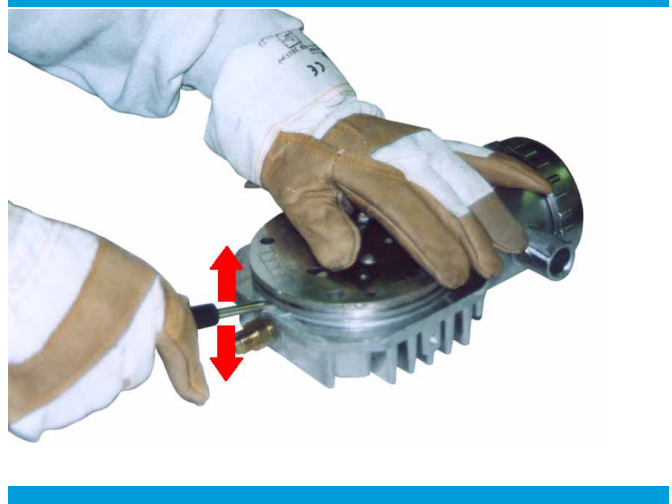

**NOTE: this operation must be carried out at a workbench.**

Check the state of the gasket found under the first stage head cover (cod. 13-01-0005) and on top of the first stage cylinder (cod. 13-01-0003 for the 88 mm and cod.16- 01-0003 for the 95 mm); if necessary replace them before assembling the lamellar valve.

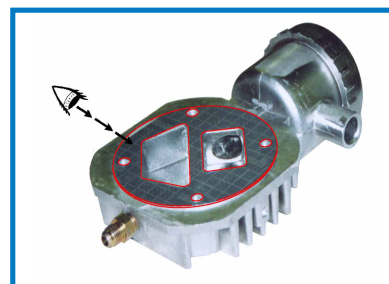

## FIRST STAGE LAMELLAR VALVE RE-ASSEMBLY

After having replaced the two gaskets found above and below the valve (see previous chapter), proceed with the assembly of the first stage valve and head cover.

Seat the gasket (cod. 13-01-0003 for the 88 mm and cod. 16-01-0003 for the 95 mm) on the first stage cylinder (cod. 13-01-0002 for the 88 mm and cod 16-01-0002 for the 95mm). Next, seat the lamellar valve taking care that the word "TOP" remains upwards and position the 4 oval holes so that they coincide with the rectangular hole found under the first stage head cover.

Lock using the 4 Allen screws previously removed, using the Allen key size 6. Note that the maximum driving torque is 2,5 Kpm.

Screw the cooling pipe of the fitting to the straight fitting (cod. 13-00-0012) found on the first stage head cover using wrench size 19.

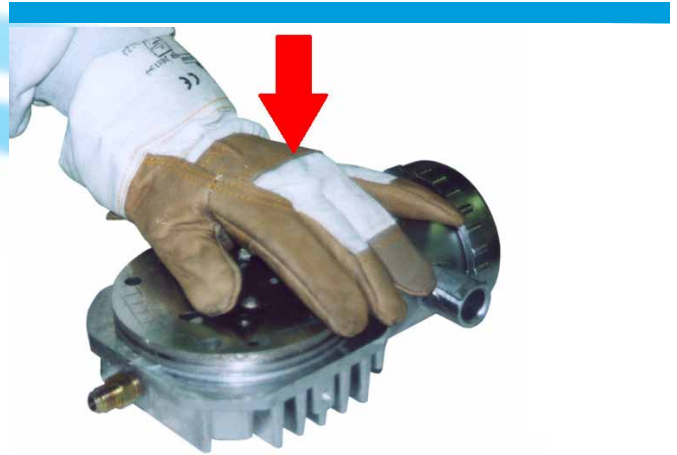

PUMP UNIT

**FIRST STAGE SAFETY VALVE**

<b>LEVEL OF SERVICING DIFFICULTY</b>	SIMPLE 	MEDIUM	DIFFICULT
--------------------------------------	---------------------------------------------------------------------------------------------	--------	-----------

**EXPECTED TIME NEEDED FOR DISMANTLEMENT AND ASSEMBLY : 10 minutes**

**TOOLS NEEDED**

 Wrench size 14	 Wrench size 16	 Thread locking Loctite		

**SPECIAL TOOLS**

<i>PUMP</i>	<i>UNIT</i>		
-------------	-------------	--	--

## 2.4 FIRST STAGE SAFETY VALVE

### Check:

Should the first stage safety valve (cod. 13-00-0195) vent with the compressor under pressure, replace it.

The safety valve must also be replaced if servicing is carried out near a pumping unit revision.

Unscrew the entire valve with wrench size 16 and replace it.

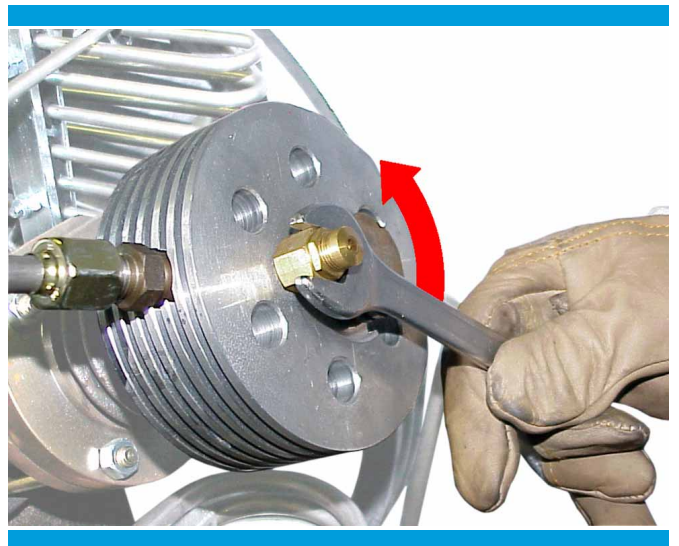

### RE-ASSEMBLY AND SETTING

Using wrench size 16 screw the first stage safety valve onto the second stage head placing some drops of the thread locking product on the valve thread.



PUMP UNIT

Dismantling the safety valve always means having to re-set it.  
To do so, proceed as described here following:

Start the compressor, loosen the safety valve lock nut by using wrench size 14 and adjusting the pressure on the pressure switch (cod. ) to maximum power. Next unscrew the top valve unit by hand until you hear it vent.

Once the above condition has been achieved, screw the safety valve on by hand, by turning the screwdriver 2-3 times completely (the vent must stop), then tighten the lock nut using wrench size 14.

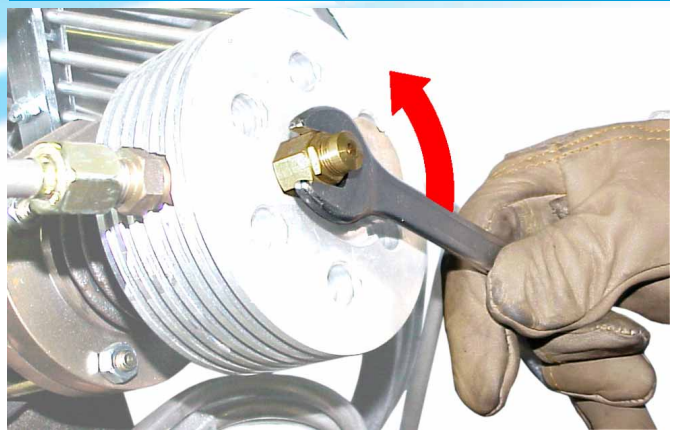

## 2.5 SECOND STAGE SAFETY VALVE

### Check :

Should the second stage safety valve (cod. 13-03-0179) vent with the compressor under pressure, replace it.

The safety valve must also be replaced if servicing is carried out near a pumping unit revision.

Unscrew the entire valve with wrench size 16 and replace it.

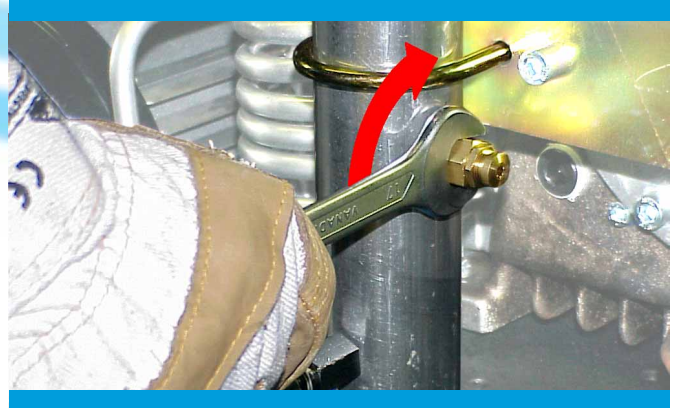

## RE-ASSEMBLY AND SETTING

Using wrench size 16 screw the second stage safety valve onto the condensate separator (cod. 13-00-0096) placing some drops of the thread locking product on the valve thread.

Dismantling the safety valve always means having to re-set it. To do so, proceed as described here following:

Start the compressor, loosen the safety valve lock nut by using wrench size 14 and adjusting the pressure on the pressure switch to maximum power. Next unscrew the top valve unit by hand until you hear it vent.

Once the above condition has been achieved, screw the safety valve on by hand, by turning the screwdriver 2-3 times completely (the vent must stop), then block the lock nut using wrench size 14.

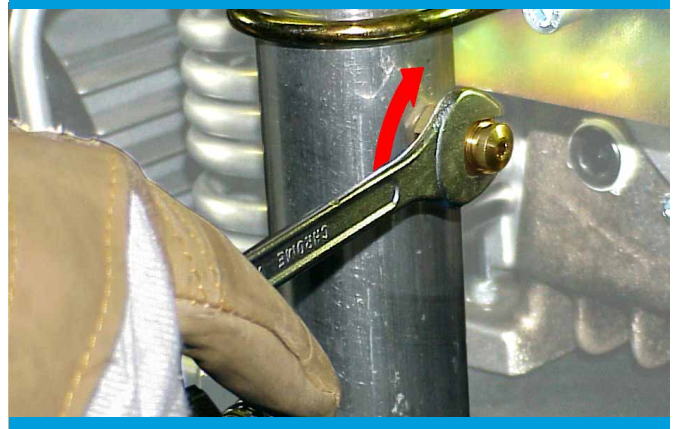
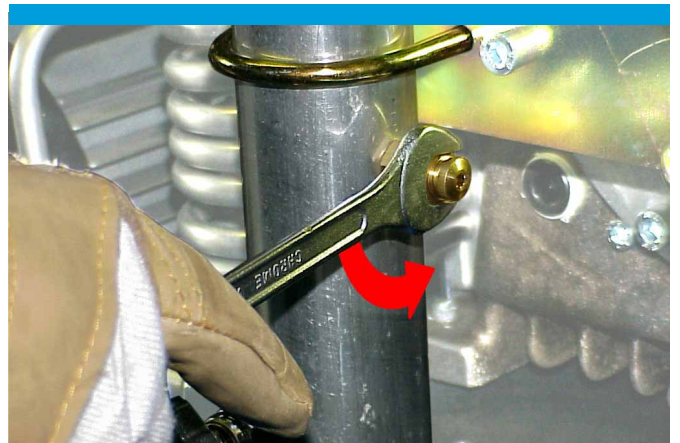









PUMP UNIT

**CYLINDERS AND PISTONS**

<b>LEVEL OF SERVICING DIFFICULTY</b>	SIMPLE ●	MEDIUM	DIFFICULT
--------------------------------------	-------------	--------	-----------

**EXPECTED TIME NEEDED FOR DISMANTLEMENT AND ASSEMBLY : 30 minutes**

**TOOLS NEEDED**

 Wrench size 13	 Wrench size 14	 Wrench size 19	 Allen key size 6	 Allen key size 8
 Allen key size 10	 Flat screwdriver	 Mallet		

**SPECIAL TOOLS**

 Compression ring tightening pliers	 Dial gauge		
---------------------------------------------------------------------------------------------------------------------------	---------------------------------------------------------------------------------------------------	--	--

## 2.6 CYLINDERS AND PISTONS

### 2.6.1 FIRST STAGE CYLINDER DISMANTLEMENT (COD. 13-01-0002 FOR THE 88 MM AND COD 16-01-0002 FOR THE 95 MM).

Proceed as follows:

In order to proceed easily, remove the cooling fan (cod. 13-00-0077). Dismantle the drive belt, positioning a lever tool (e.g. a screwdriver) as shown in the figure and by making the pulley rotate by hand make sure that the belt comes out of its seat in the race provided in the pulley.

Unscrew the 4 Allen screws locking the fan to the fan hub (cod. 13-00-0074) using Allen key size 10 and holding the fan still with one hand.

Next, unscrew also the central Allen screw using Allen key size 8 (always holding the fan still with one hand).

Remove the fan flange (cod. 13-00-0082) and extract the fan.

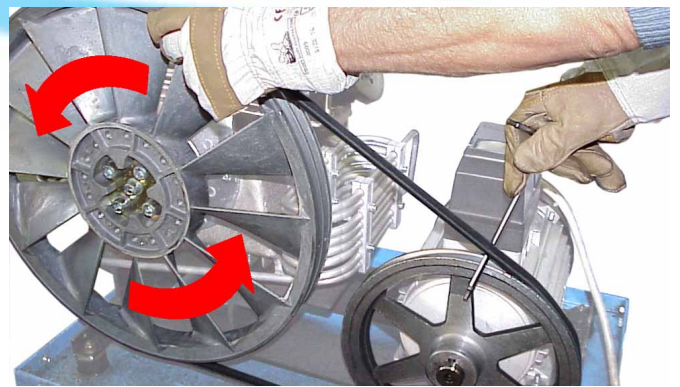

PUMP UNIT

Unscrew the fitting connecting the cooling pipes to the condensate separator (cod. 13-00-0096) and to the third stage head (cod. 13-03-0027) with wrench size 14.

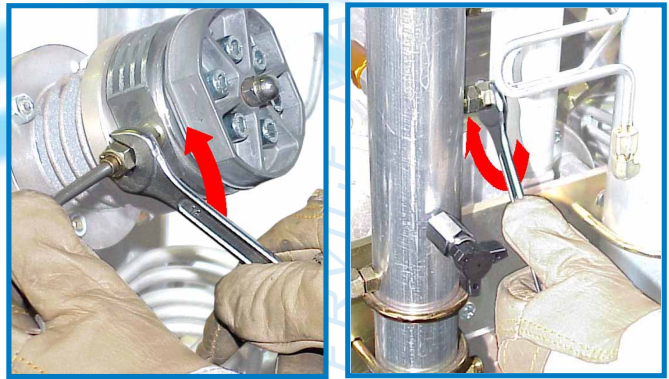

Using Allen key size 6, unscrew the 2 Allen screws locking the tube holding brackets (cod. 13-00-0133) to remove the entire cooling pipe (cod. 13-03-0023).

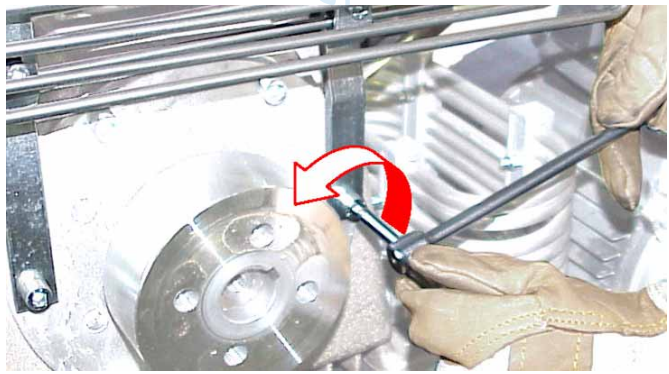

Unscrew the fitting of the cooling pipe from the third stage head using wrench size 19.



Unscrew the 4 Allen screws locking the first stage head cover (cod. 13-01-0006) to its cylinder using Allen key size 6.



Remove the head. Should it appear stuck to the cylinder give small mallet (in rubber or wood in order to avoid damages) strokes on the head.

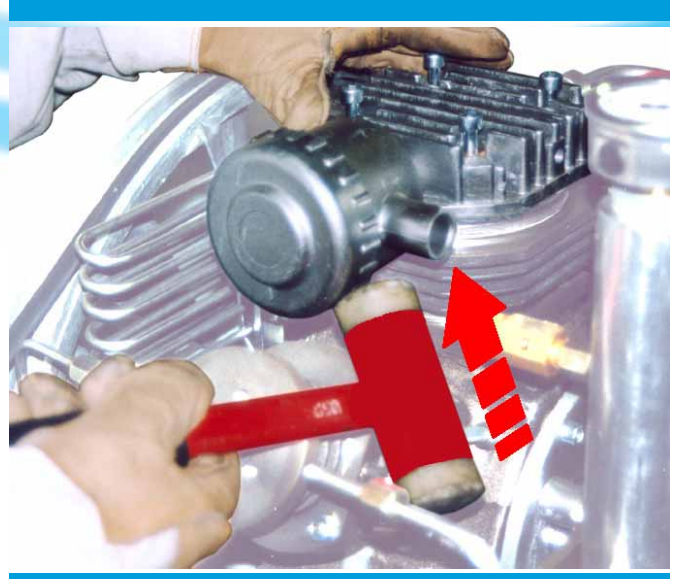

**Check:**

Clean the first stage cylinder with care and check with naked eye if there are traces of excessive wear or scratching.

Should there be any scratches present, replace the cylinder.

If the cylinder has only regular traces of normal wear, take a more precise measurement using a dial gauge.



**NOTE:**

The cylinders cannot be re-bored. Should this be necessary, remove the cylinder, unscrew the 4 nuts locking the first stage cylinder to the crankcase of the pumping unit (cod. 13-00-0001) using a size 13 wrench.

By manually rotating the cooling fan (cod. 13-00-0077), bring the first stage piston (cod. 13-01-0117 for the 88 mm or cod. 16-01-0117 for the 95 mm) to the bottom dead centre in order to make the cylinder easier to extract.

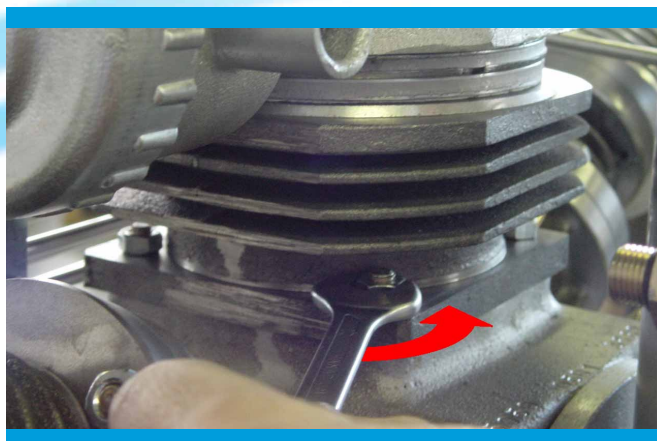

**FIRST STAGE CYLINDER RE-ASSEMBLY (COD. 13-01-0002 FOR THE 88 MM AND COD 16-01-0002 FOR THE 95 MM).**

If you have removed the cylinder proceed as follows:  
Replace the O-ring (cod. 13-01-0007) of the first stage cylinder.

Position the cylinder (lubricating the lining is recommended) taking particular care both to the compression rings (cod. 13-01-0118 for the 88 mm and cod 16-01-0118 for the 95 mm) which must be held with the appropriate clamp and to the first stage piston (cod. 13-01-0117 for the 88 mm or cod. 16-01-0117 for the 95 mm) in order to bring the piston and the compression rings to the top dead centre.

The compression rings must be positioned so that the cut of the elastic clamp are 120° apart.

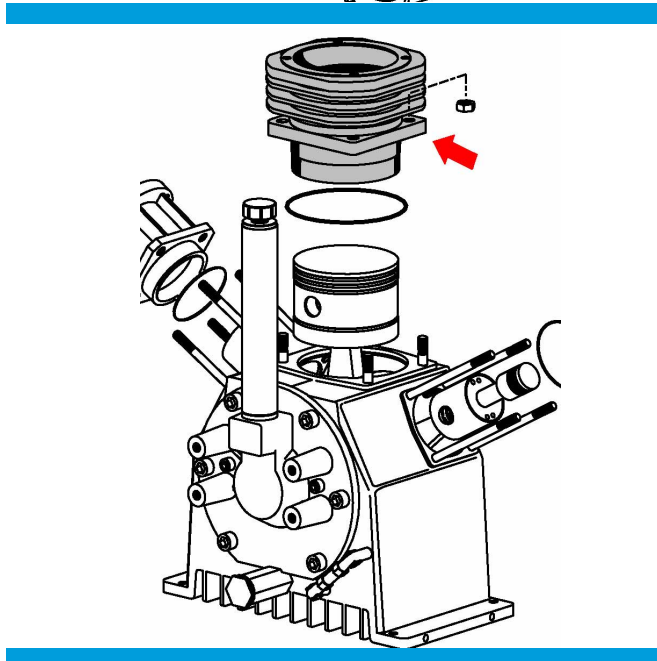
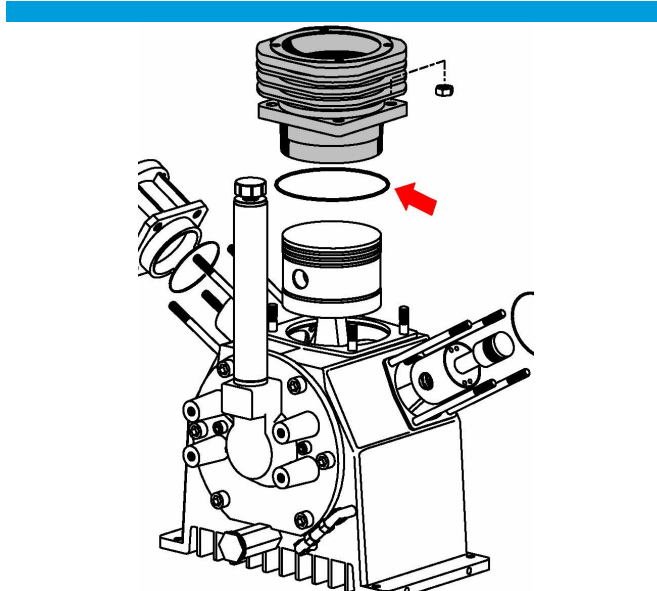

After having positioned the cylinder screw on the 4 nuts locking (cod. 13-00-0018) the first stage cylinder to the pumping unit crankcase (cod. 13-00-0001) using wrench size 13.

Clean the first stage cylinder with care.

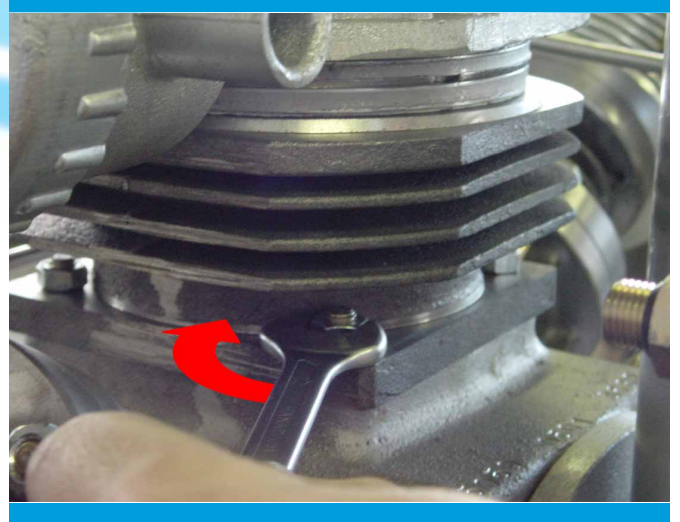

Check the state of the gasket found under the first stage head cover (cod. 13-01-0005) and on top of the first stage cylinder (cod. 13-01-0003 for the 88 mm and cod. 16-01-0003 for the 95 mm). Should it prove necessary, replace the gasket before assembling the lamellar valve.

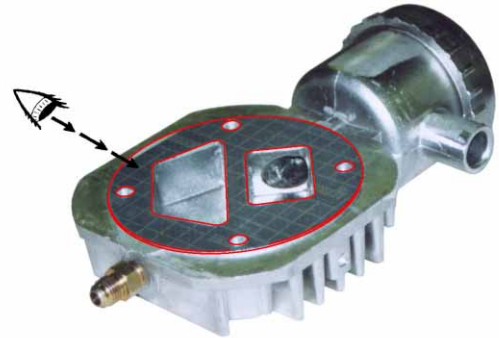

After having replaced the two gaskets found above and below the valve, proceed with the re-assembly of the valve and the first stage head cover.

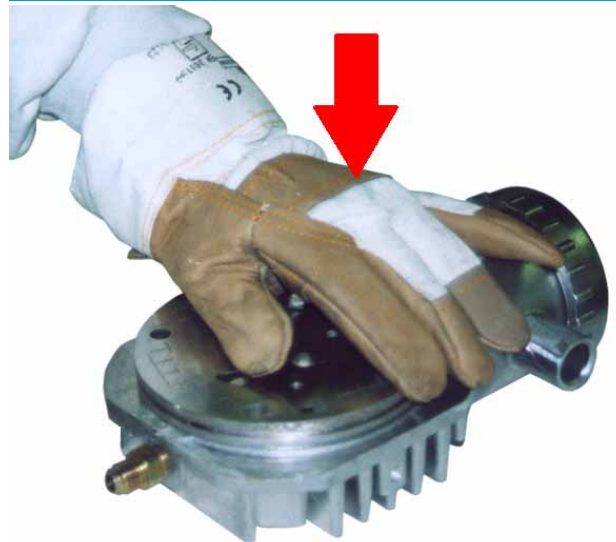

PUMP UNIT

Position the gasket (cod. 13-01-0003 for the 88 mm and cod. 16-01-0003 for the 95 mm) on the first stage cylinder (cod. 13-01-0002 for the 88 mm and cod 16-01-0002 for the 95 mm). Next position the lamellar valve, taking care that the word "TOP" remains upward and position the 4 oval holes so that they coincide with the rectangular hole found under the first stage head cover.

Using Allen key size 6 lock using the 4 Allen screws previously removed. Note that the maximum driving torque is 2,5 Kpm.

Screw the fitting of the cooling pipe onto the first stage head using wrench size 19.



**Now, if you do not intend to operate on the second and third stage cylinders and on their relevant pistons, proceed with assembly of the cooling fan, should you decide to operate on these, follow this operation next.**

Using Allen key size 6, screw the 2 Allen screws locking the tube holding brackets (cod. 13-00-0133) and re-assemble the entire cooling pipe.

Driving torque 1 Kpm.

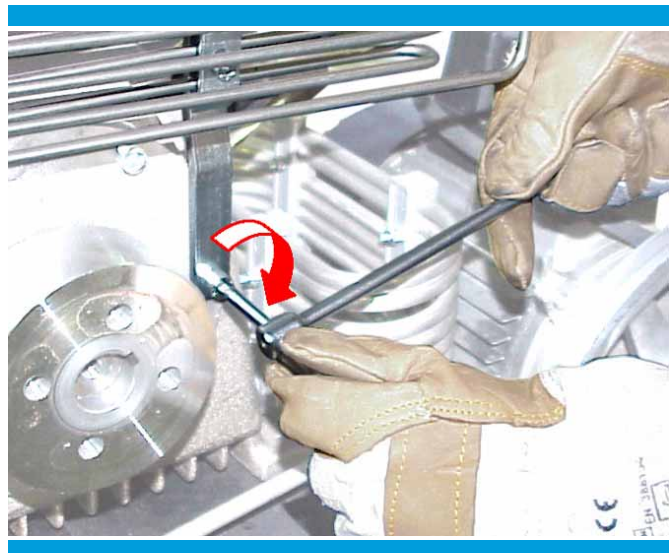

Screw the fittings of the cooling pipe onto the condensate separator (cod. 13-00-0096) and onto the third stage head (cod. 13-03-0027) with wrench size 14.

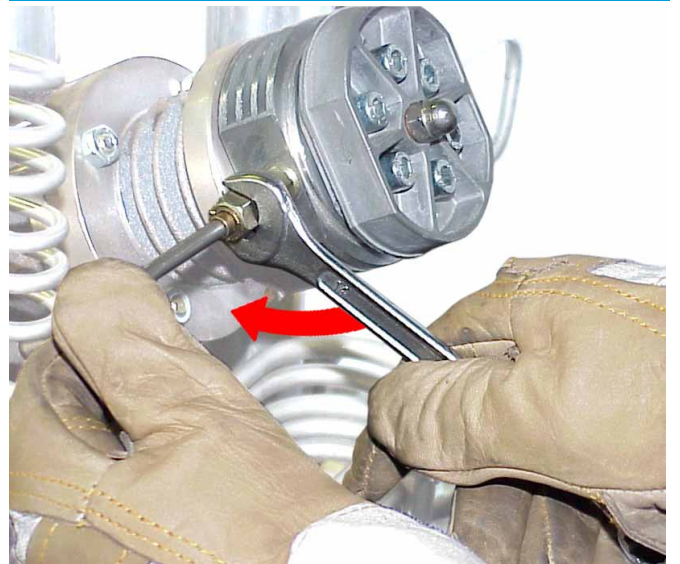
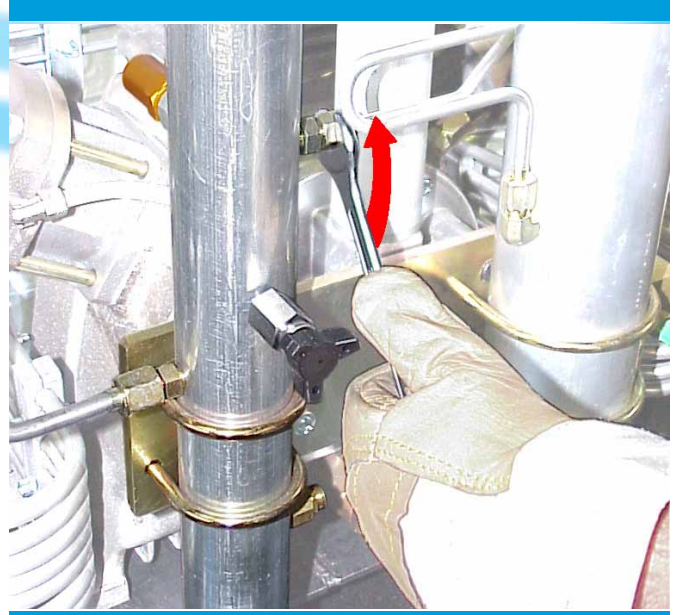

Position the fan and the fan flange (cod. 13-00-0082).



Next screw the central Allen screw with a couple of drops of thread locking product, using an Allen key size 8 (holding the fan still with one hand).



Screw the 4 Allen screws locking the fan to the fan hub (cod. 13-00-0074), with a couple of drops of thread locking product. Next, using the Allen key size 10 tighten it holding the fan still with one hand.

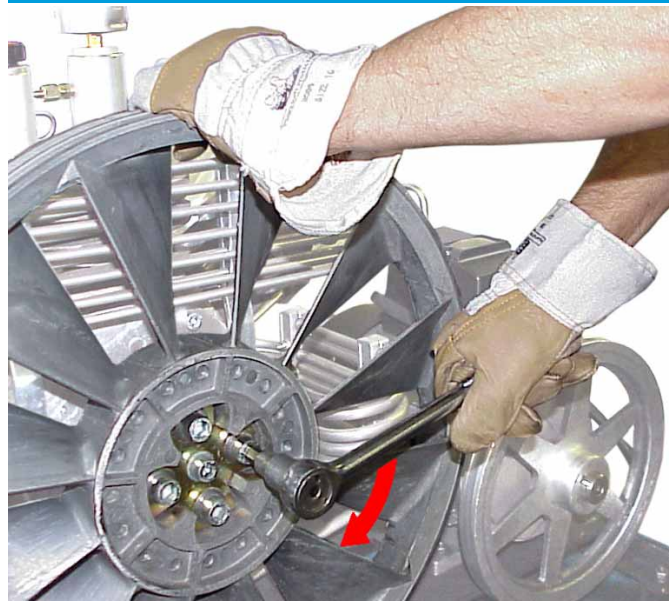

Reassemble the drive belt (replace if necessary), positioning a lever tool (e.g. a screwdriver) as shown in the figure and by making the pulley rotate by hand make sure that the belt is positioned in the race provided in the motor pulley.

Check the tension of the belt, should an adjustment be necessary operate as described in the Compressor Instruction Manual, refer to the Maintenance chapter.

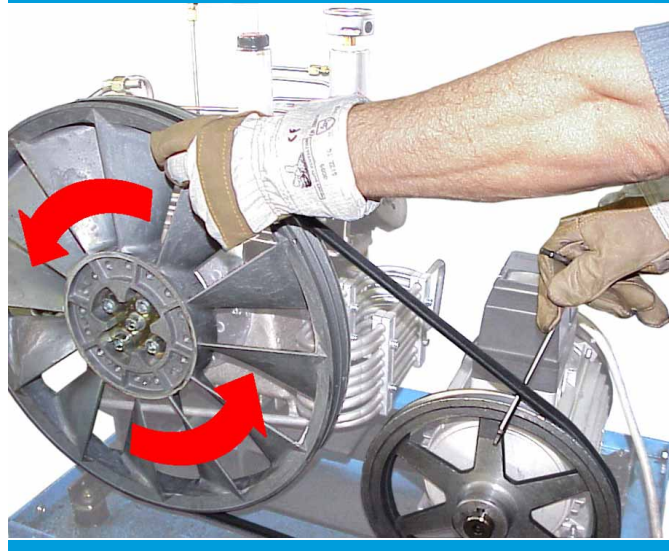

### 2.6.2 SECOND STAGE CYLINDER DISMANTLEMENT (COD. 13-02- 0043 FOR THE 36 MM AND COD. 16-02-0043 FOR THE 38 MM)

Proceed as follows:

Unscrew the 2 fittings of the cooling pipes on the second stage head on the air intake and discharge side, using wrench size 19.

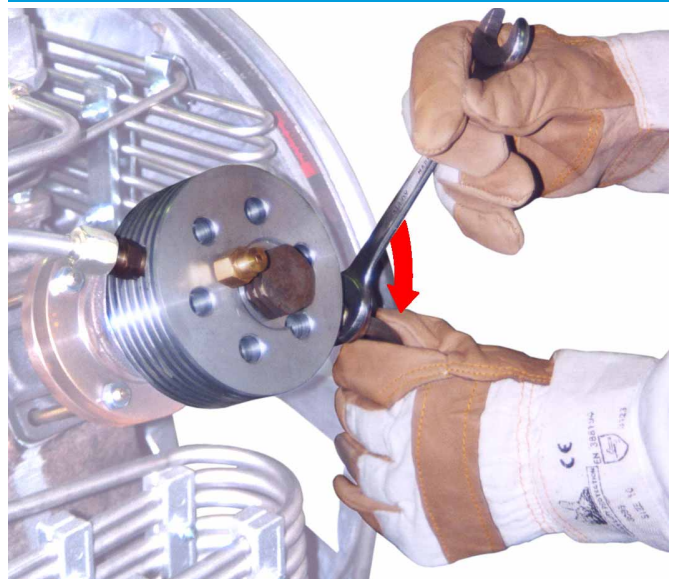

Unscrew the 6 Allen screws locking the second stage head (cod. 13-01-0046) to its cylinder (cod. 13-02-0043 for the 36 mm and cod. 16-02-0043 for the 38 mm), using Allen key size 6.

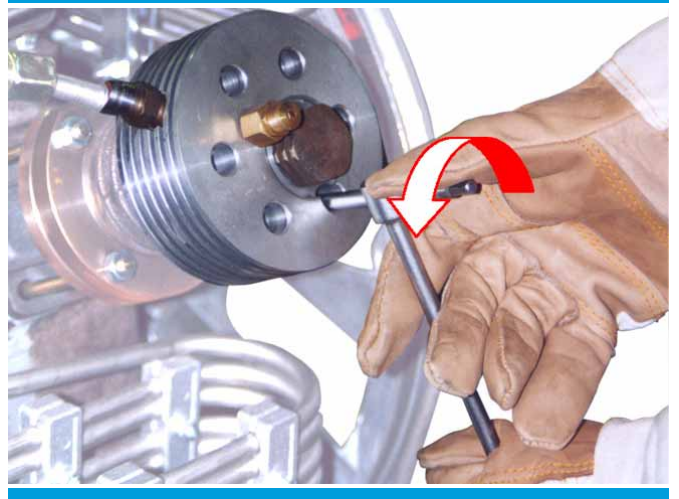

PUMP UNIT

**Check:**

Clean the second stage cylinder with care and check with naked eye if there are traces of excessive wear or scratching.

Should there be any scratches present, replace the cylinder.

If the cylinder has only regular traces of normal wear, take a more precise measurement using a dial gauge.



**NOTE:** The cylinders cannot be re-bored. Should this be necessary, remove the cylinder, unscrew the 4 nuts locking the second stage cylinder to the second stage guiding cylinder (cod. 13-02-0037) using wrench size 13.

By manually rotating the cooling fan (cod. 13-00-0077), bring the second stage piston (cod. 13-02-0112 for the 36 mm or cod. 16-02-0112 for the 38 mm) to the bottom dead centre in order to make the cylinder easier to extract.

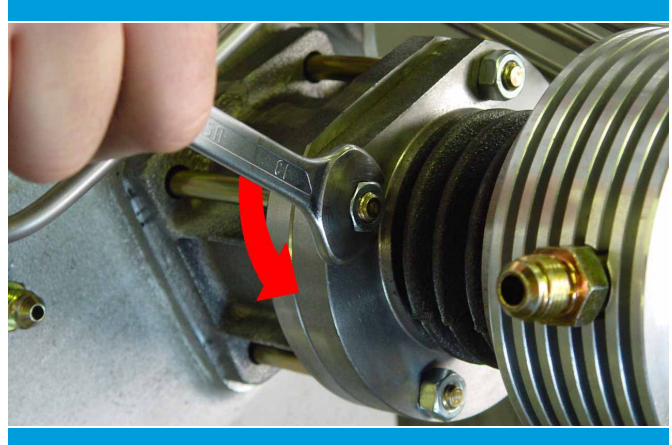

**SECOND STAGE CYLINDER RE-ASSEMBLY (COD. 13-02-0043 FOR THE 36 MM AND COD. 16-02-0043 FOR THE 38 MM)**

If the cylinder has been removed, proceed as follows:

Replace the O-ring (cod. 13-00-0015) of the second stage guiding cylinder (cod. 13-02-0037) placing the former under the latter.

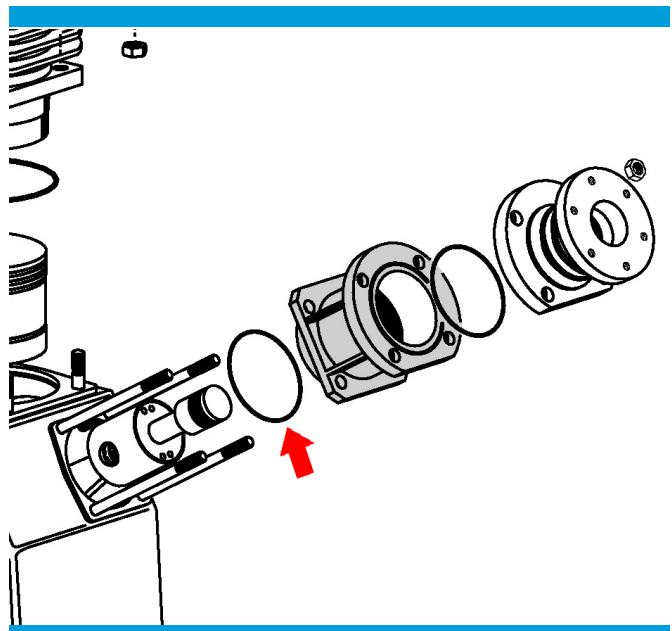

Position the second stage guiding cylinder (cod. 13-02-0037) (lubricating the lining is recommended) taking particular care both to the compression rings (cod. 13-02-0113 for the 36 mm and cod. 16-02-0117 for the 38 mm) and to the second stage piston (cod. 13-02-0112 for the 36 mm and cod. 16-02-0112 for the 38 mm).

The appropriate clamp must hold the compression rings.

Replace the O-ring (cod. 13-00-0039) of the second stage cylinder (cod. 13-02-0043 for the 36 mm and cod. 16-02-0043 for the 38 mm), positioning it in its seat found on the top of the second stage guiding cylinder (cod. 13-02-0037).

Position the second stage cylinder (lubricating the lining is recommended) taking particular care both to the compression rings (cod. 13-02-0113 for the 36 mm and cod. 16-02-0113 for the 38 mm) which must be held by the appropriate clamp and to the second stage piston (cod. 13-02-0112 for the 36 mm or cod. 16-02-0112 for the 38 mm) in order to bring the piston complete of compression rings to the top dead centre.

The compression rings must be positioned so that the cut of the elastic clamp are 120° apart.

After having positioned the cylinder screw the 4 nuts locking the second stage cylinder to the second stage guiding cylinder (cod. 13-02-0037) using wrench size 13.

Clean the second stage cylinder with care.

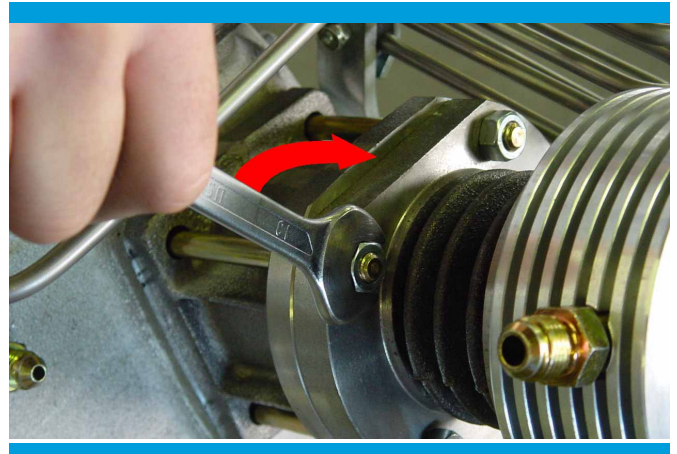
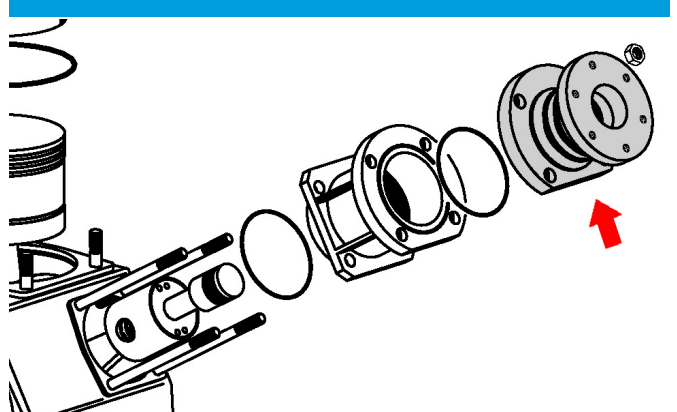
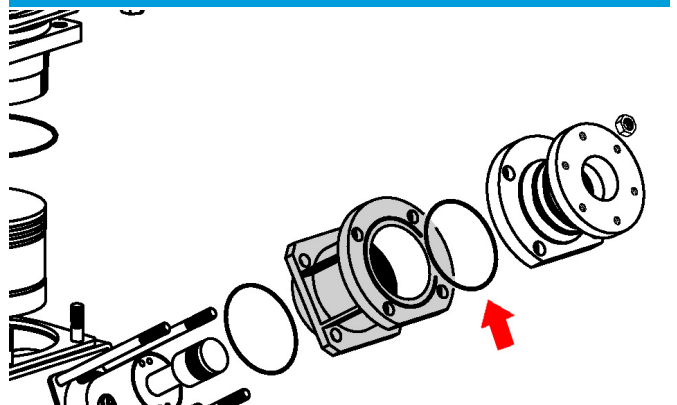
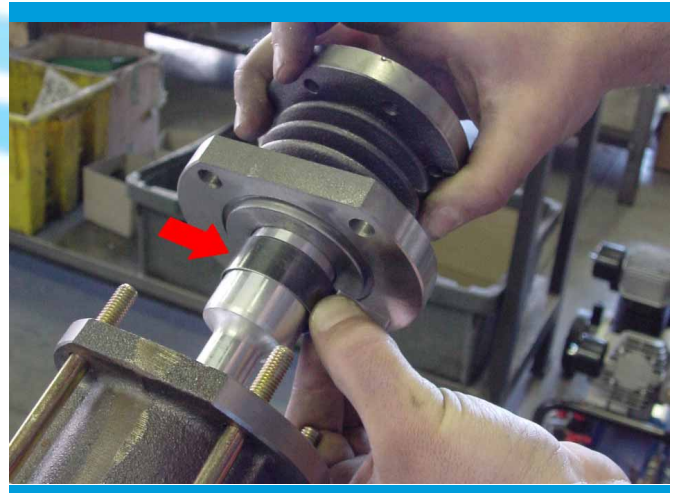

Lock the head to the cylinder using the 6 Allen screws previously removed, using Allen key size 6. Note that the maximum driving torque is 2,5 Kpm.

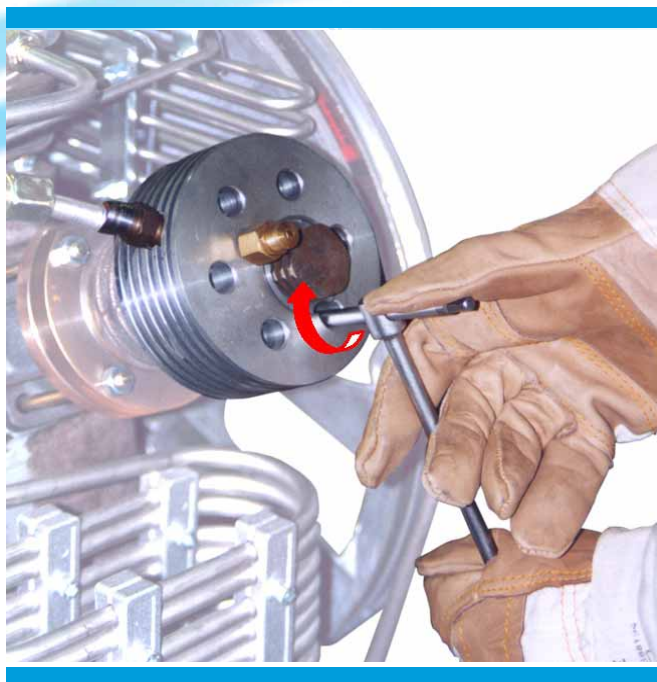

Screw the 2 fittings of the cooling pipes to the second stage head on the air intake and discharge side, using wrench size 19.

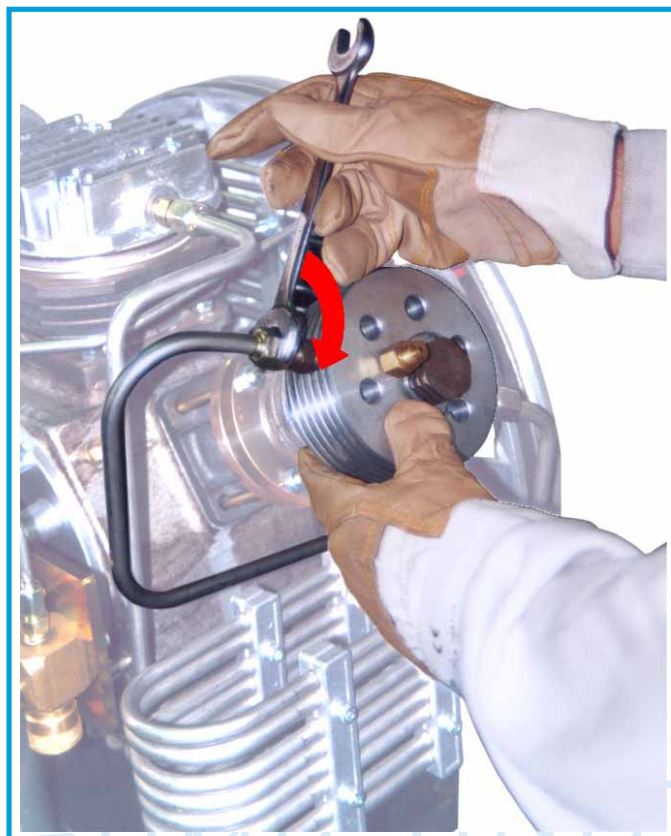

**2.6.3 THIRD STAGE CYLINDER  
DISMANTLEMENT (COD. 13-  
03-0125 FOR THE 14 MM AND  
COD. 13-02-0017)**

Proceed as follows:

Unscrew the fittings of the cooling pipes on the third stage head using wrench size 19 for the air intake side and size 14 for the discharge side.

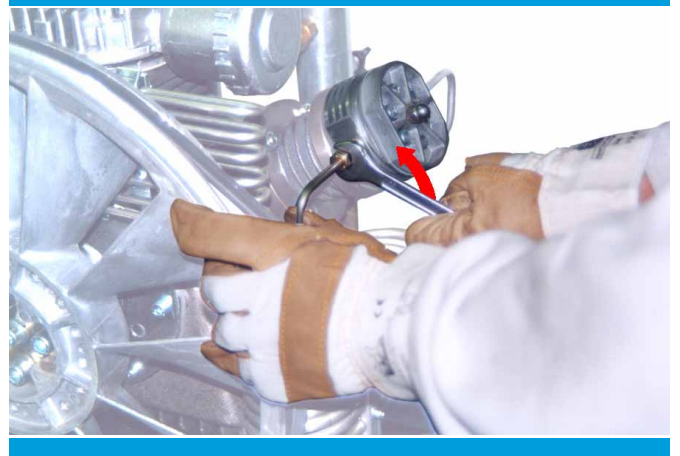

Unscrew the 6 Allen screws locking the cover (cod. 13-03-0030) and third stage head (cod. 13-03-0027) to the relevant cylinder using Allen key size 6.



PUMP UNIT

Using wrench size 14, unscrew the lubrication indicator pipe (cod. 13-00-0019) from the elbow fitting found on the cylinder.

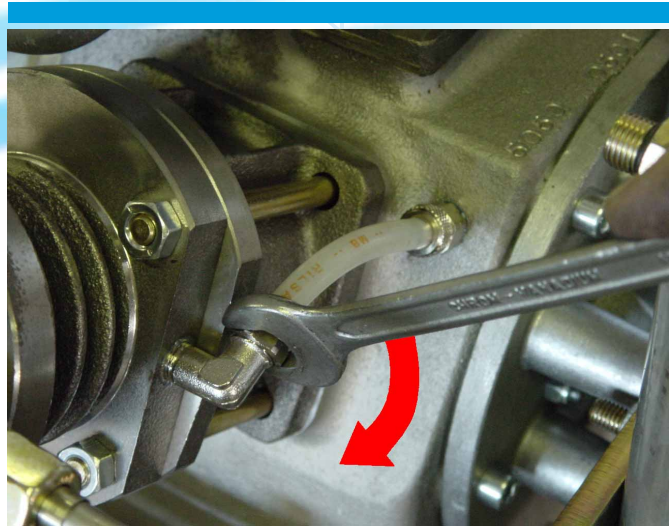

Insert a 14 mm plastic tool in the central hole of the third stage cylinder (cod. 13-03-0125) and extract it from the guiding cylinder (cod. 13-02-0017).

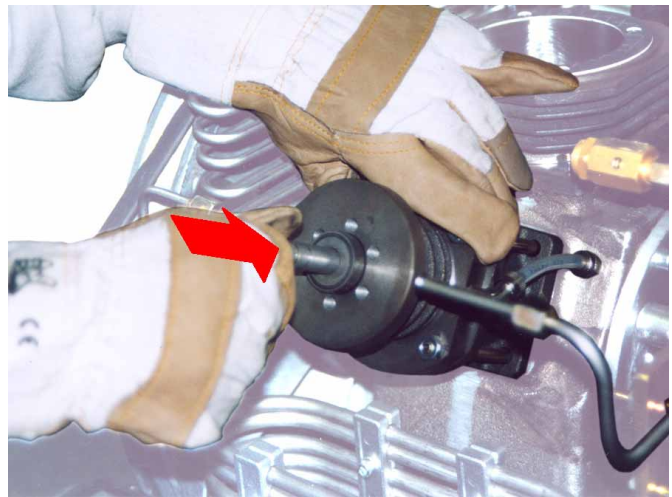

Unscrew the 4 nuts locking the third stage cylinder (cod. 13-02-0017) to the third stage 60 mm guiding cylinder (cod. 13-03-0190) using wrench size 13 and extract it.

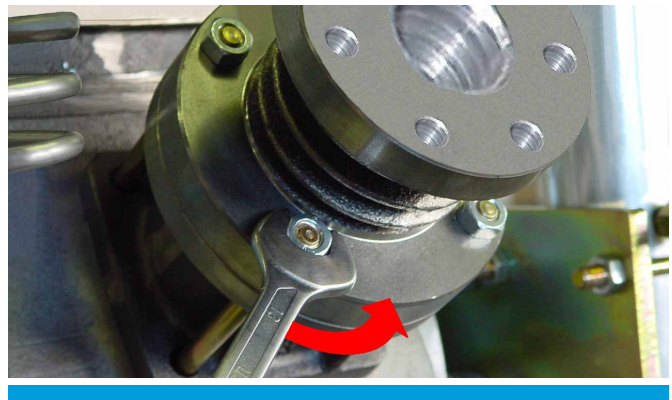

**Check:**

Clean the third stage 14 mm cylinder (cod. 13-03-0125) and the third stage cylinder (cod. 13-03-0190) with care and check with naked eye if there are traces of excessive wear or scratching.

Should there be any scratches present, replace both the cylinders.

If the cylinders have only regular traces of normal wear, take a more precise measurement using a dial gauge for the third stage cylinder (cod. 13-02-0017) and a micrometer for the third stage 14 mm cylinder (cod. 13-03-0125).

**NOTE:** The cylinders cannot be re-bored.



### THIRD STAGE CYLINDER RE-ASSEMBLY (COD. 13-03-0125 FOR THE 14 MM AND COD. 13-02-0017)

If the cylinder has been removed, proceed as follows:

Replace the O-ring (cod. 13-00-0015) of the third stage guiding cylinder (cod. 13-03-0190) positioning the former under the latter.

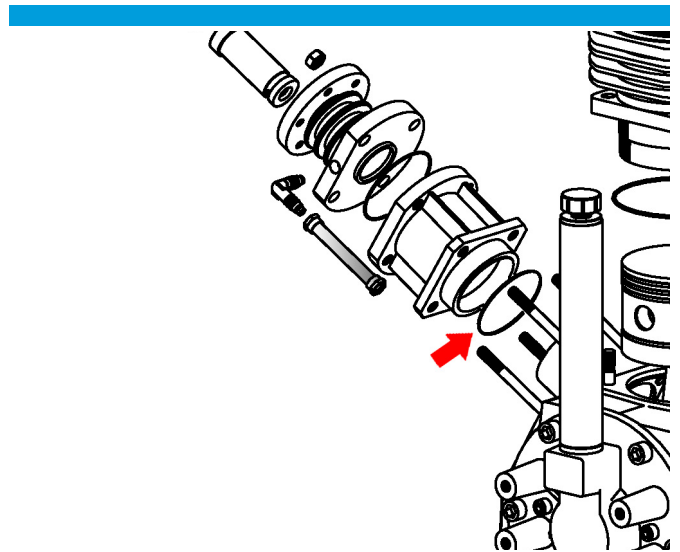

Position the third stage guiding cylinder (cod. 13-03-0190) (lubricating the lining is recommended) taking particular care to the third stage guiding sliding block (cod. 13-03-0120).

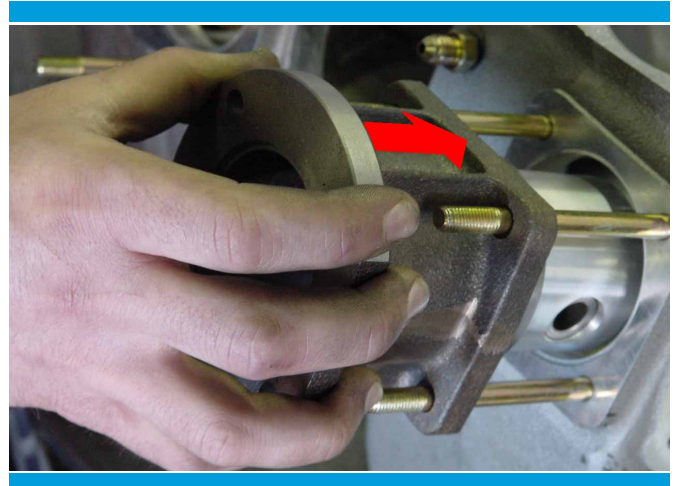

PUMP UNIT

Replace the O-ring (cod. 13-00-0039) of the third stage cylinder (cod. 13-02-0017), positioning it in its seat on top of the third stage guiding cylinder. (cod. 13-03-0190).

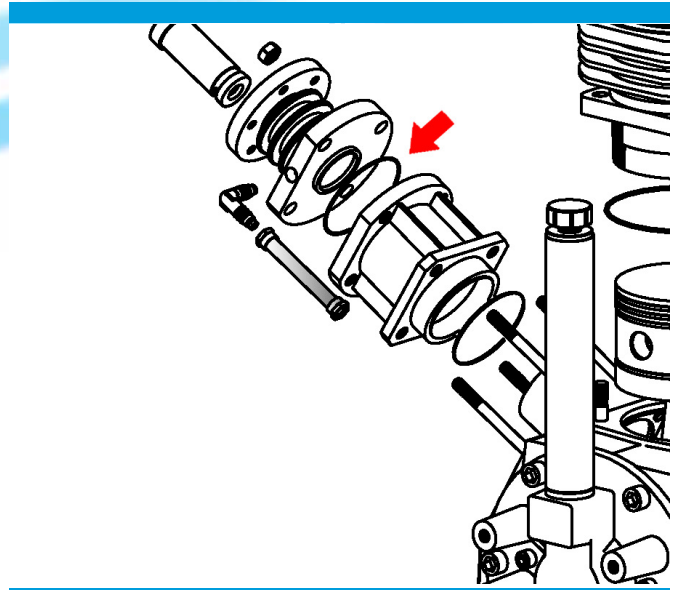

Position the third stage guiding cylinder (cod. 13-02-0017) and clean with care.

After having positioned the cylinder with its rounded side placed towards the filters, screw the 4 nuts locking the third stage cylinder onto the third stage 60 mm guiding cylinder (cod. 13-03-0190) using wrench size 13.

Next, after having lubricated the third stage 14 mm cylinder (cod. 13-03-0125) by putting oil in its appropriate hole, insert the cylinder in its seat, lining up the center hole with the crankshaft found on the third stage guiding cylinder (cod. 13-02-0017).

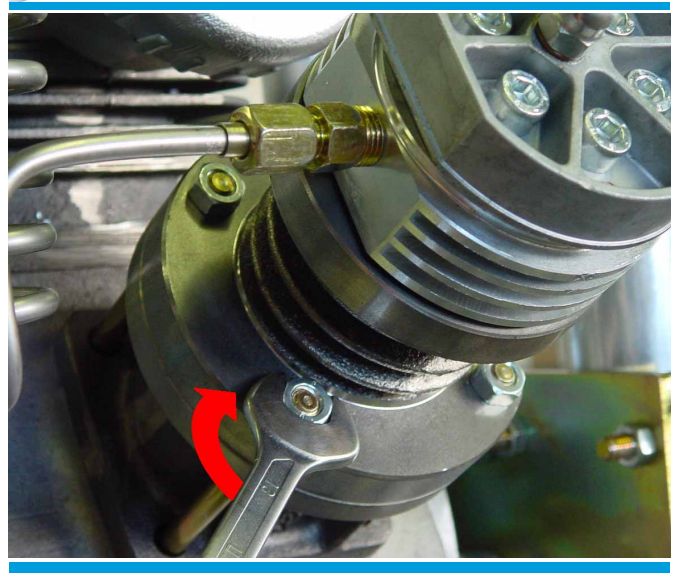

Lock the entire third stage cover/head unit to the cylinder with the 6 Allen screws previously removed, using Allen key size 6; maximum driving torque is 2,5Kpm.



Using wrench size 14, re-screw the lubrication indicator pipe (cod. 13-00-0019) onto the elbow fitting found on the cylinder.

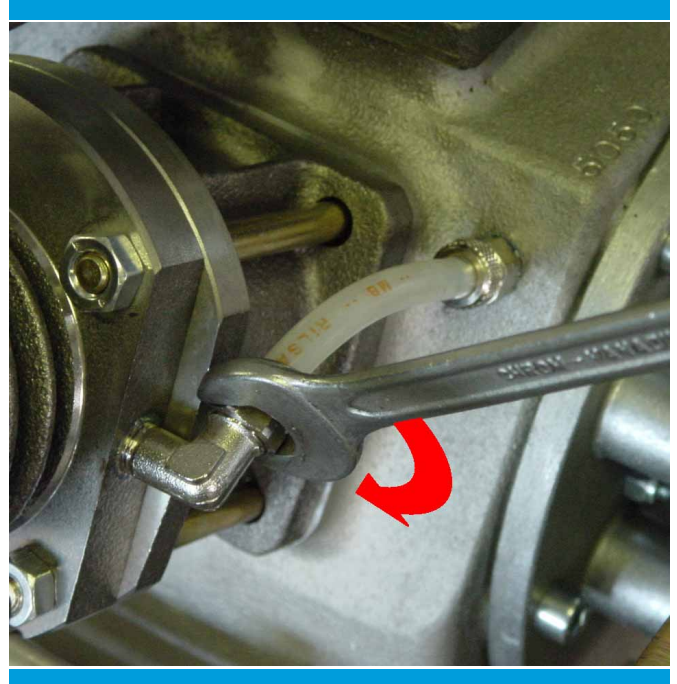

Screw the 2 fittings of the cooling pipes onto the second stage head on the air intake and discharge side, using wrench size 19 for the air intake side and 14 for the discharge side.











**PISTON DISMANTLEMENT**



<b>LEVEL OF SERVICING DIFFICULTY</b>	SIMPLE	MEDIUM ● ●	DIFFICULT
--------------------------------------	--------	---------------	-----------

**EXPECTED TIME NEEDED FOR DISMANTLEMENT AND ASSEMBLY : 30 minutes**

**TOOLS NEEDED**

 Wrench size 10	 Wrench size 14	 Wrench size 19	 Allen key size 6	 Allen key size 8
 Flat screwdriver	 Round-nose pliers	 Mallet		

**SPECIAL TOOLS**

 Ring extractor	 Thickness gauge		
-------------------------------------------------------------------------------------------------------	--------------------------------------------------------------------------------------------------------	--	--

## 2.6.4 PISTON DISMANTLEMENT

Using c-clip pliers, remove the 2 c-clips near the relevant pin.

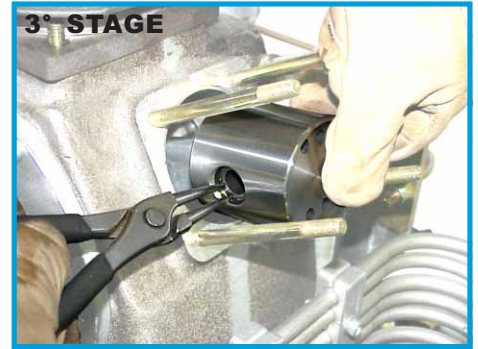
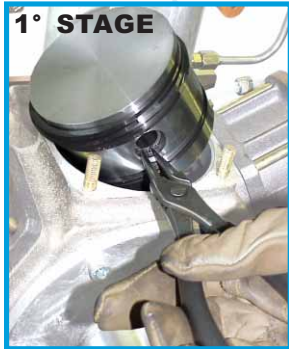

Pull out the pin locking the piston to the connecting rod taking particular care, and placing a cloth to protect the piston and to avoid it being damaged. Using a screw (or a screwdriver) give light hammer strokes to pull the pin out.

Remove the piston complete with its compression rings.

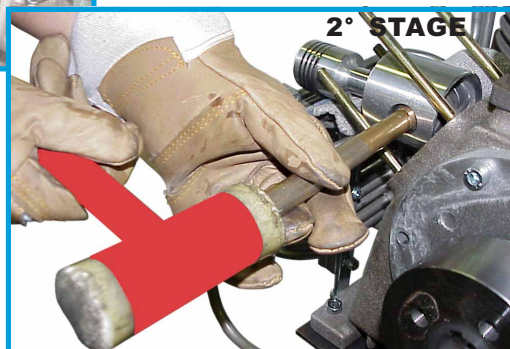
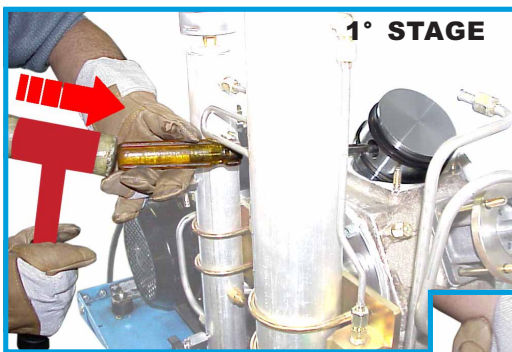

PUMP UNIT

## PISTON RE-ASSEMBLY

Using c-clip pliers, position one of the 2 c-clip rings in the race found on the piston.

Lubricate with oil the pin locking the piston to the connecting rod and, taking particular care, place a cloth to protect the piston and to avoid it being damaged. Using a screw (or a screwdriver) give light hammer strokes very carefully to make the pin roll between the piston and the roller bearing of the connecting rod.

After having introduced the pin completely, position also the second seeger ring.

If the compression rings have been removed, re-position them using the appropriate extractor.

The compression rings must be placed so that the cut of the elastic clamp are 120° apart.



## COMPRESSION RINGS REPLACEMENT

### Checks:

The following checks must be carried out about every 2000 hours of operation.

### Compression rings

Using the thickness gauge measure the gap of the compression rings in the piston races considering that the minimum tolerance is 0,02 mm and the maximum is 0,04 mm.

In order to replace the compression rings, remove and re-insert them using the compression ring extractor as shown in the figure.

Always lubricate the bands after having replaced them.

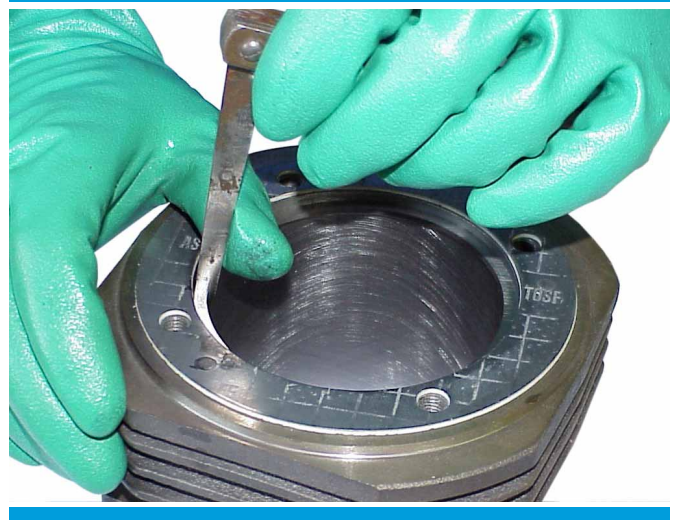
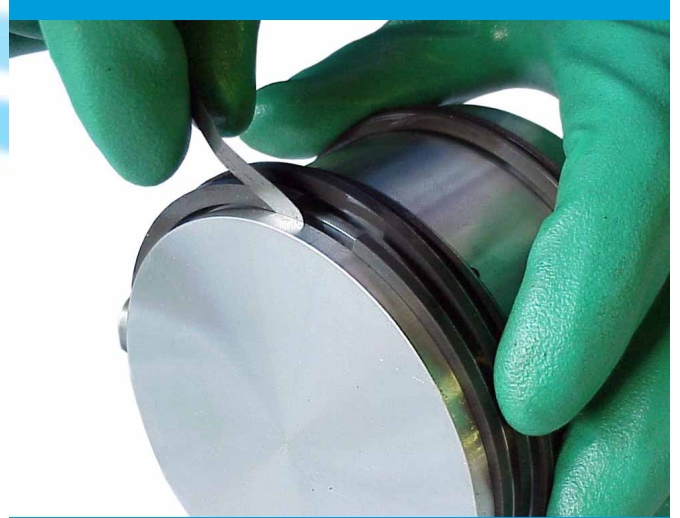

**CRANKSHAFT DISMANTLEMENT**



<b>LEVEL OF SERVICING DIFFICULTY</b>	SIMPLE	MEDIUM	DIFFICULT ● ● ●
--------------------------------------	--------	--------	--------------------

**EXPECTED TIME NEEDED FOR DISMANTLEMENT AND ASSEMBLY : 30 minutes**

**TOOLS NEEDED**

 Wrench size 13	 Allen key size 6	 Flat screwdriver	 Work bench vise	 Mallet
 Round-nose pliers				

**SPECIAL TOOLS**

 Extractor	 Thickness gauge		
--------------------------------------------------------------------------------------------------	--------------------------------------------------------------------------------------------------------	--	--

## 2.7 CRANKSHAFT (COD. 13-00-0098) AND CONNECTING ROD DISMANTLEMENT

### Checks:

The following checks must be carried out about every 2000 hours of operation.

#### **Connecting rod bearings**

The roller bearings must be able to turn freely, and must not have any sign of wear or scratches.

#### **Axial play of the connecting rods on the crankshaft**

Position all the connecting rods on one side and using the thickness gauge measure their play, considering that the minimum play is 0,4 mm and the maximum is 0,8 mm.

#### **Radial play of the bearings**

The correct radial play of the connecting rods roll bearings must allow for them to be inclined from 1 to 2mm.

Should these limits not be respected, replace the entire crankshaft and connecting rods.

#### **Crankshaft hard rings (cod.13-00-0132)**

These rings should not have any scratching, replace them if they do.

### WARNING

FOR FAN, CYLINDER, PISTON, TUBE, FILTER AND SEPARATOR DISMANTLEMENT FOLLOW THE INSTRUCTIONS FOUND IN THE PREVIOUS CHAPTERS.

Discharge all the oil present in the pumping unit following the instructions found in the Compressor's Instructions Manual, referring to the Maintenance chapter.

Remove the fan hub (cod. 13-00-0074) using the extractor as shown in the figure.

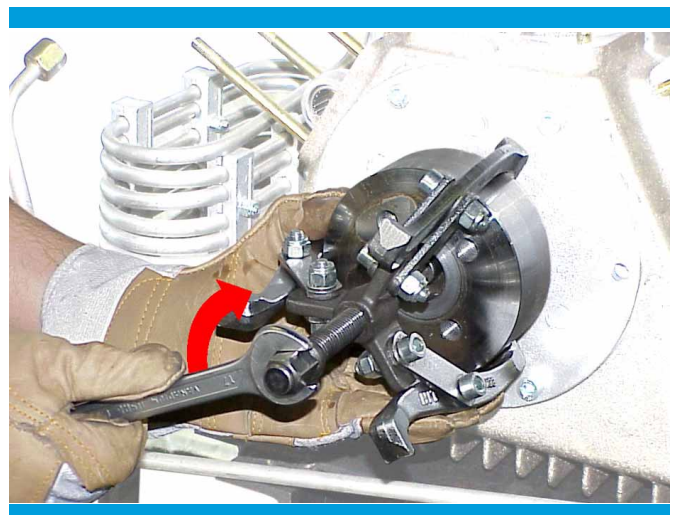
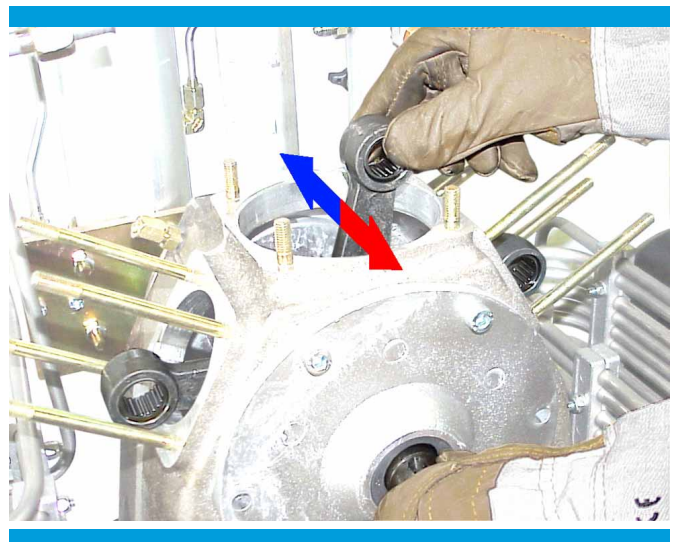
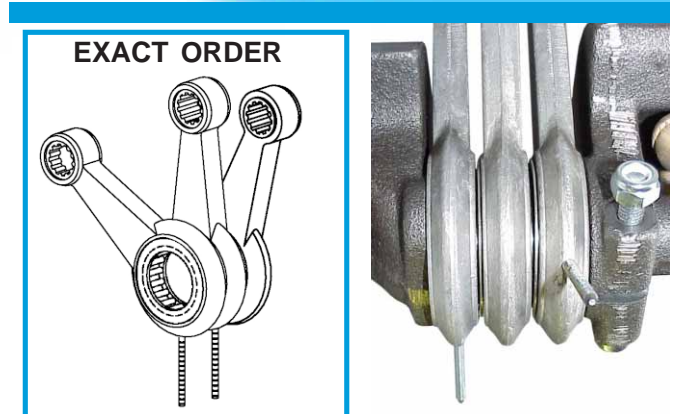

Remove the closed flange (opposite side of the fitting, with a small key) by unscrewing the locking Allen screws. The following operations must be carried out at a workbench.

Using an extractor, remove the ring found near the crankshaft.

**Use of a vise is recommended.**

Loosen the Allen screw locking the counterweight (cod. 13-00-0100) using Allen key size 6 and wrench size 13 to keep the self-locking nut still.

Remove the Allen screw and its self-locking nut locking the counterweight (cod. 13-00-0100).

Pull out, in this order, the following elements from the crankshaft: counterweight, connecting rod, roller bearing and spacers.

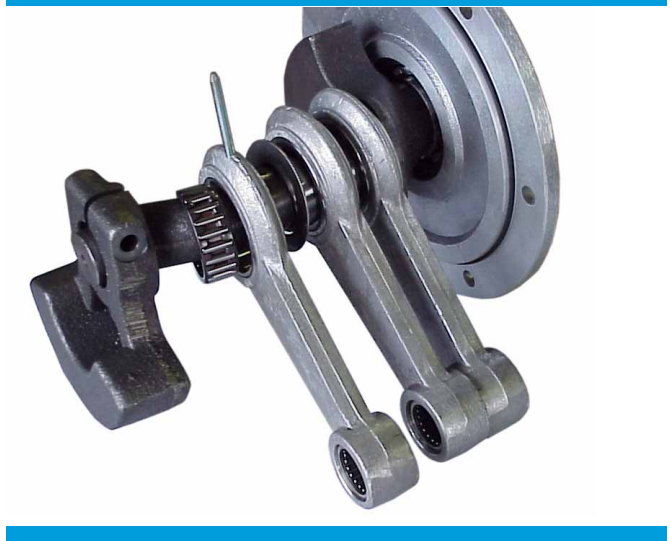
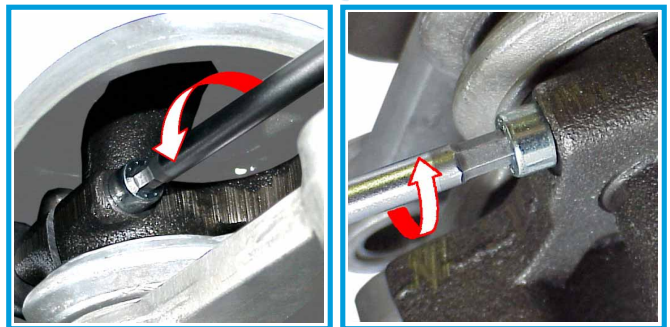
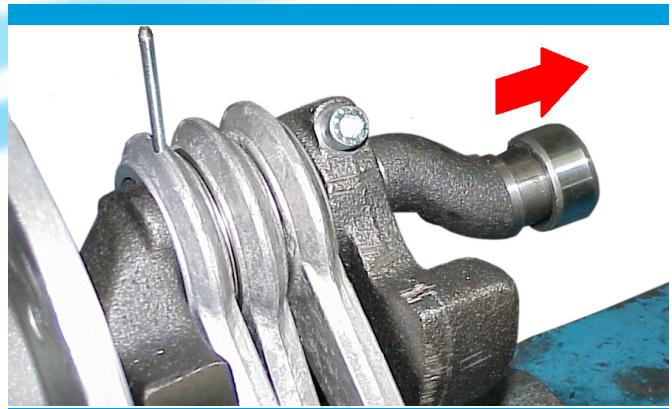

Extract the key from the crankshaft with light mallet strokes (see figure).

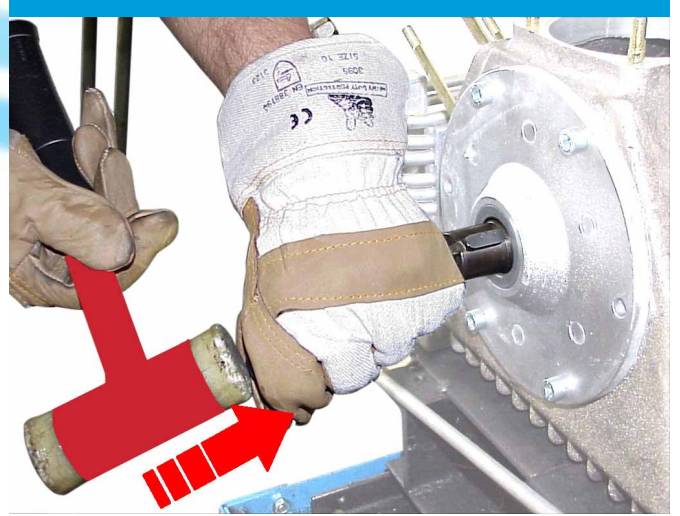

Remove the seal (cod. 13-00-0073) using a screwdriver or pliers.



Remove the locking c-clip (cod. 13-00-0072) from the flange using the appropriate pliers.

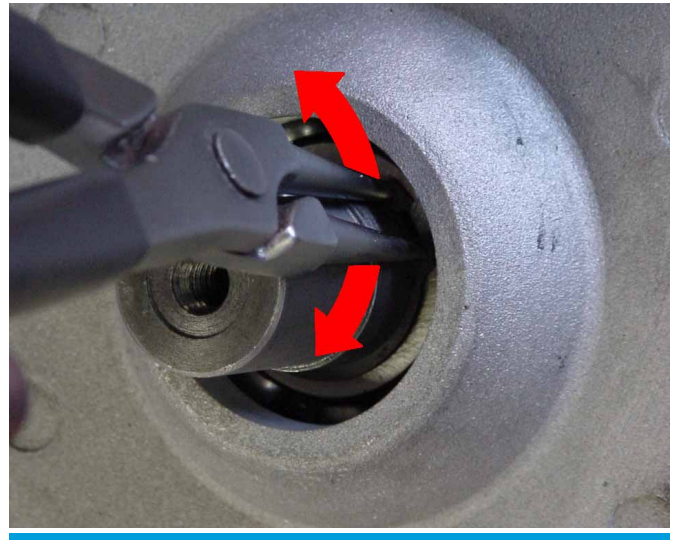

Unscrew the 4 Allen screws locking the flange (cod. 13-00-0071) using Allen key size 6.

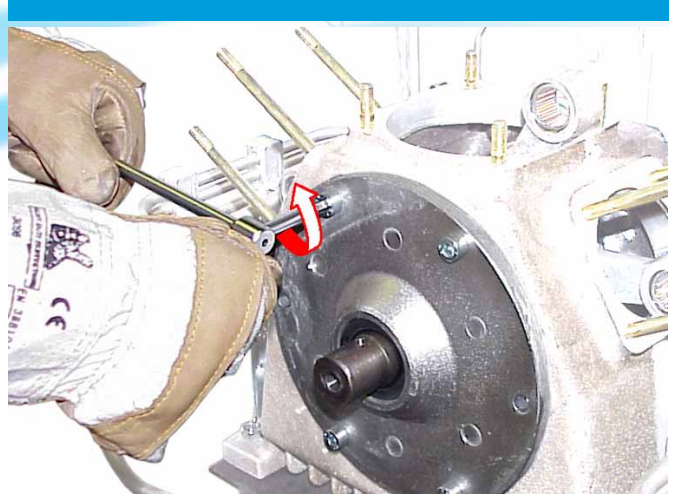

Pull out the crankshaft unit from the crankcase of the pumping unit.

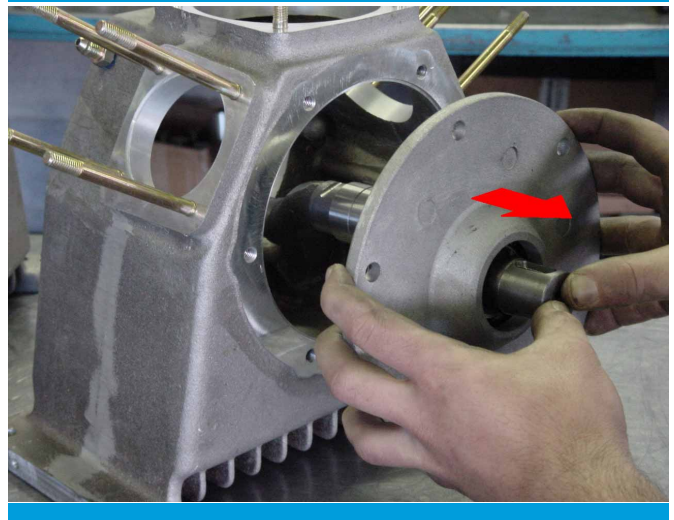

**CRANKSHAFT (cod. 13-00-0098)  
AND CONNECTING RODS  
RE-ASSEMBLY**

Mount the gooseneck fitting on the flange and lock the fitting with the appropriate c-clip (cod. 13-00-0072).

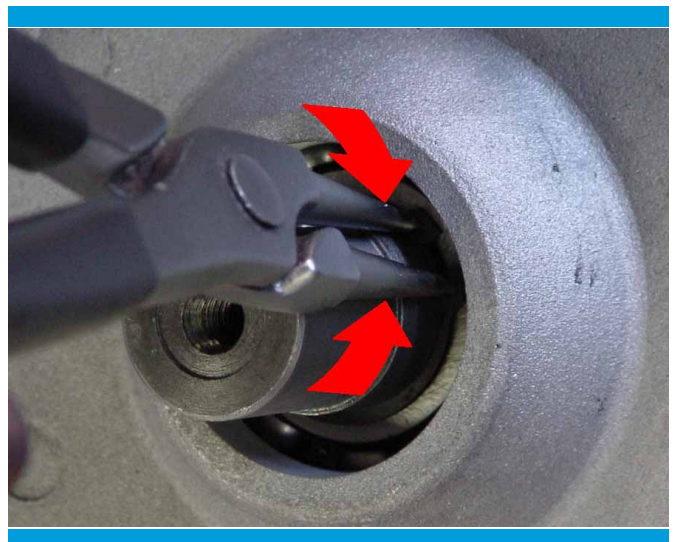

Position the seal (cod. 13-00-0073) in the seat found on the flange.

Position the o-ring (cod. 13-00-0062) under the flange (cod.13-00-0071) in the appropriate seat and screw the 4 Allen screws locking the flange with Allen key size 6.

Insert the entire fitting/flange unit in the crankcase, by tightening the 4 screws locking the flange (cod. 13-00-0071) with Allen key size 6.

Position the key on the gooseneck fitting.

Insert, in this order, the following in the fitting: spacers, roll bearings, connecting rods and counterweight.

Insert the Allen screw locking the counterweight and its nut.

Tighten the Allen screw locking the counterweight (cod.13-00-0100) using Allen key size 6 and wrench size 13 to keep the self-locking nut still.

Position the ring on the gooseneck fitting and mount the closed flange locking it with the Allen screws.

Insert the fan hub (cod. 13-00-0074) on the fitting taking care to centre the key found on the fitting.

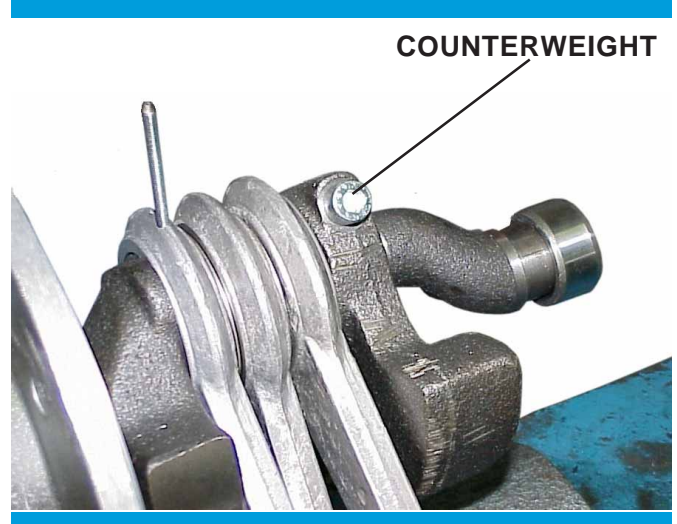
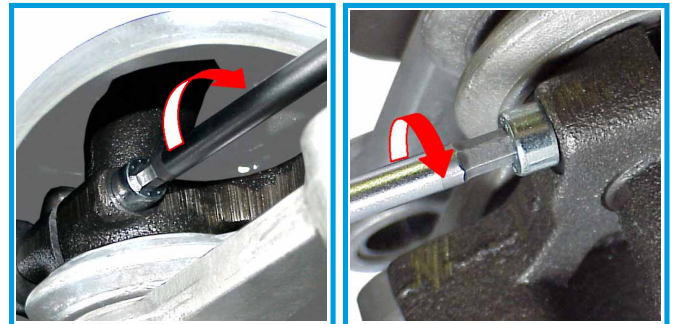
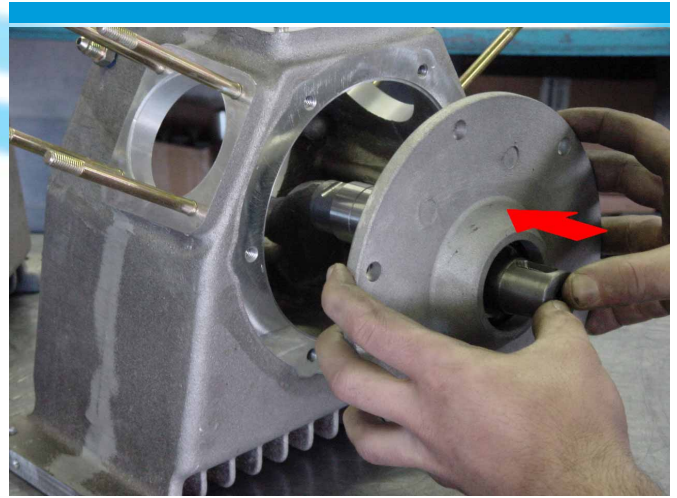







PUMP UNIT

**CONDENSATE SEPARATOR**

<b>LEVEL OF SERVICING DIFFICULTY</b>	SIMPLE	MEDIUM ● ●	DIFFICULT
--------------------------------------	--------	---------------	-----------

**EXPECTED TIME NEEDED FOR DISMANTLEMENT AND ASSEMBLY : 70 minutes**

**TOOLS NEEDED**

 Wrench size 14	 Wrench size 17-19	 Wrench size 27	 Pliers for external seeger	 Flat screwdriver
 Adjustable wrench				

**SPECIAL TOOLS**

--	--	--	--

## 3 FILTERING SYSTEM

**WARNING: DEPRESSURISE THE ENTIRE MACHINE BEFORE CARRYING OUT ANY WORK ON THE COMPRESSORS**

### 3.5.1 CONDENSATE SEPARATOR

In order to replace the condensate separator unit, proceed as follows.

Unscrew the top fitting of the cooling pipe using wrench size 17.

Next, unscrew the bottom fitting of the cooling pipe using wrench size 19.

Unscrew the 2 fittings of the cooling pipe (found on the right hand side of the separator), using wrench size 14.

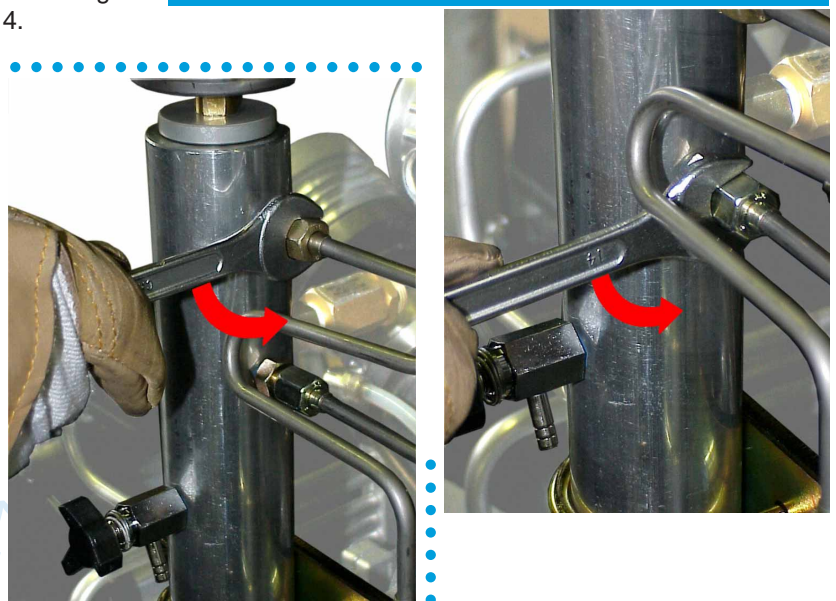
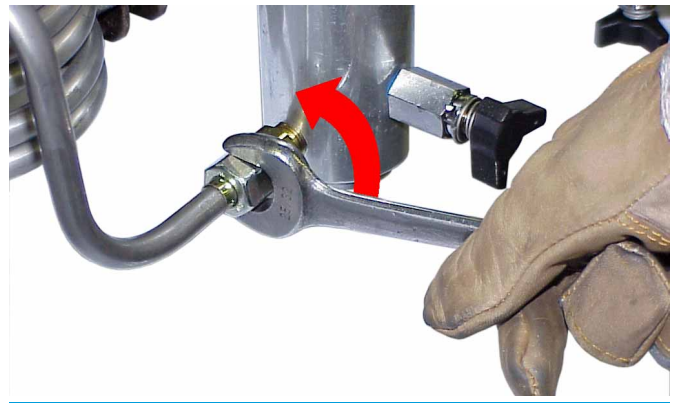
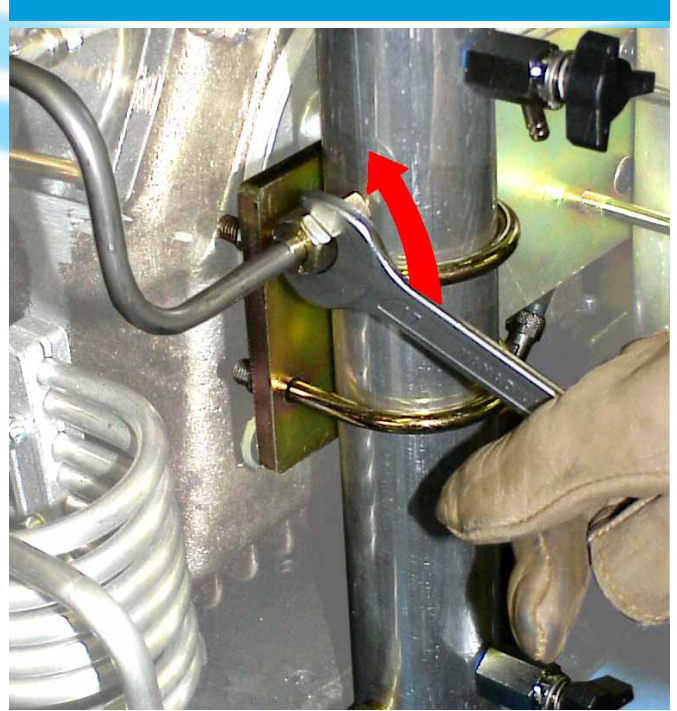

F I L T E R I  
S Y S T E M

Unscrew the nuts locking the 2 brackets holding the separator (cod. 13-00-0102) and remove the separator completely.

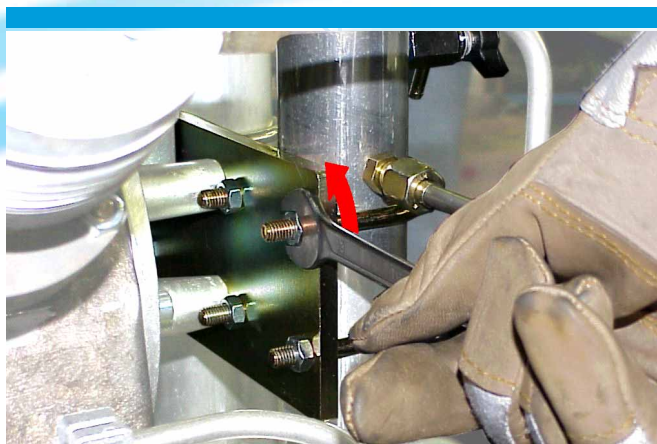

Should you want to replace only the O-rings (cod. 13-00-0182) found under the top and bottom cover, this can be carried out without having to remove the separator from its seat (support bracket).

In order to carry out this operation on the STANDARD models, unscrew the fitting of the top cover (found under the pressure gauge), using wrench size 14.

For all the other models, unscrew the top cover using wrench 27.

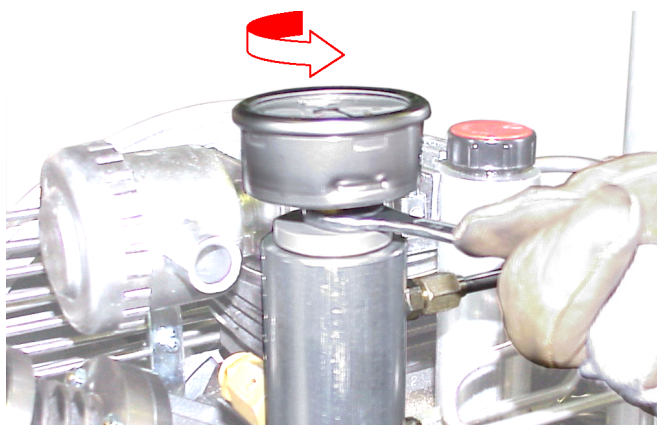

**MODEL  
STANDARD**



**MODELS  
OPEN  
COMPACT  
MINI E SUPER-SILENT**

The bottom cover (cod. 13-00-0184) must be unscrewed using pliers.

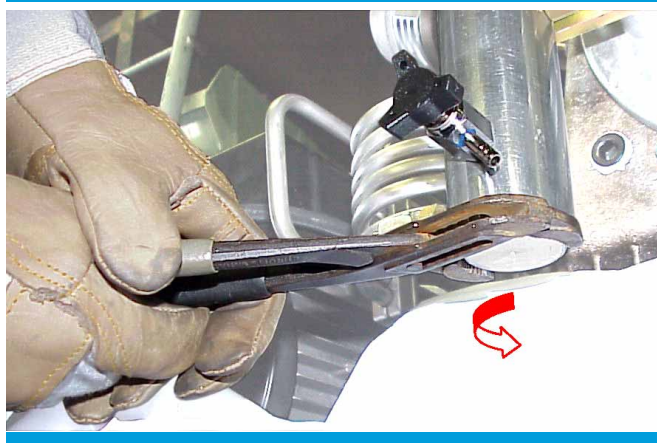

Remove the O-ring from its cover using a screwdriver.



## CONDENSATE SEPARATOR COMPONENTS RE-ASSEMBLY

If only the top and bottom covers of the separator have been unscrewed, without having to remove it from its seat (support plate) all that must be done is:

- Position the new O-rings (cod. 13-00-0182) in the appropriate race found on each cover brushing some grease both on the gaskets and on the thread;
- the bottom cover (cod. 13-00-0184) must be screwed on using pliers.

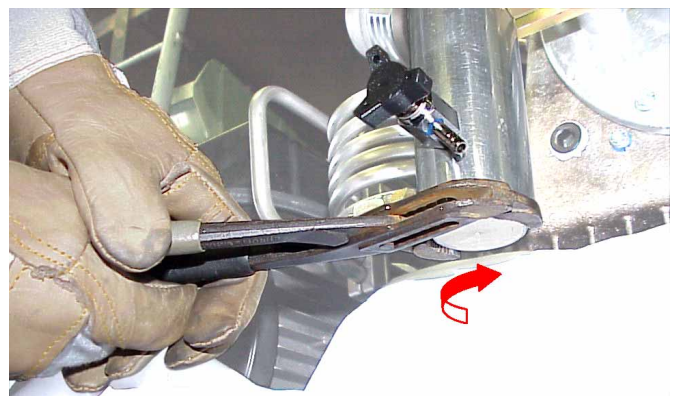

On the STANDARD models, screw the fitting of the top cover complete with pressure gauge, using wrench size 14. For all the other models screw the top cover on with wrench size 27.

**MODEL  
STANDARD**



If the condensate separator has been dismantled completely, to re-assemble proceed as follows:

Position the condensate separator between the 2 locking brackets (cod. 13-00-0102) and tighten the 4 nuts previously removed.

Screw on the 2 fittings of the cooling pipe (on the left-hand side of the separator), using wrench size 14.

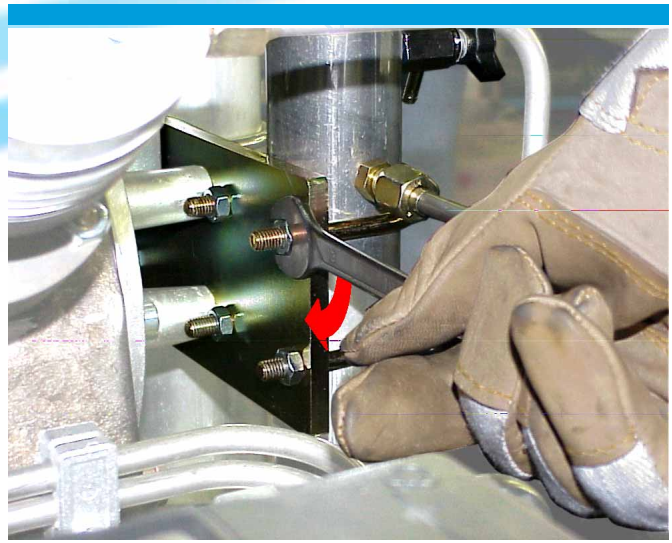

Next screw on the bottom fitting of the cooling pipe using wrench size 19.

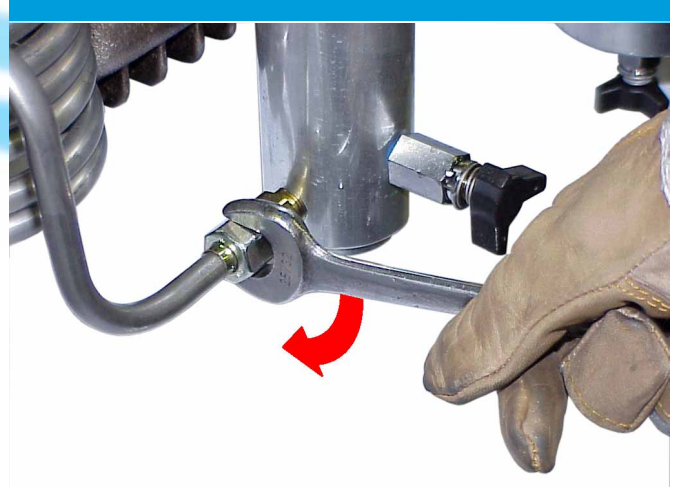

Screw on the top fitting of the cooling pipe using wrench size 17.

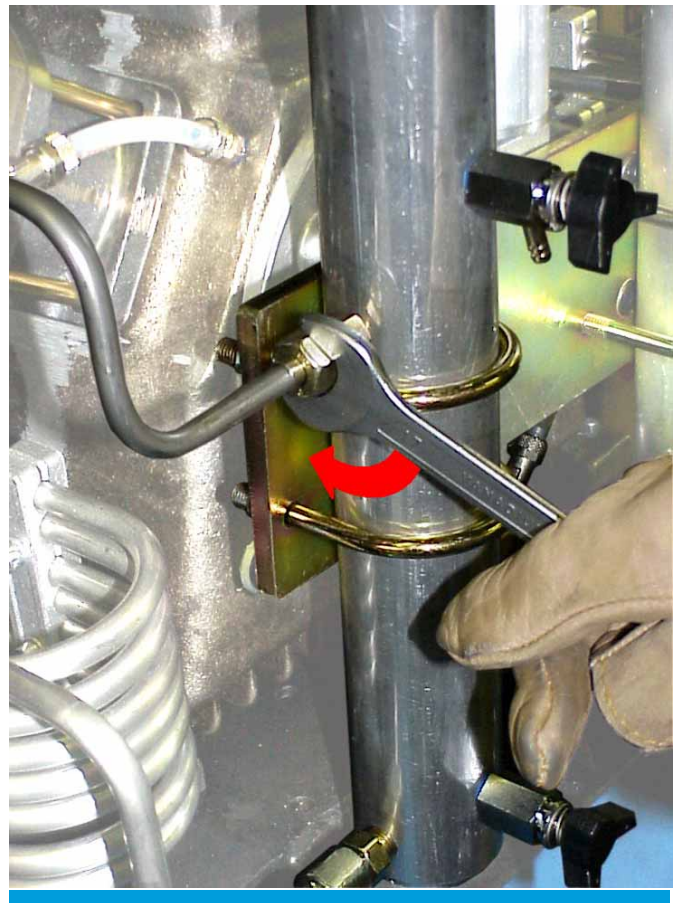





**3 FILTERING SYSTEM**

<b>LEVEL OF SERVICING DIFFICULTY</b>	SIMPLE	MEDIUM ● ●	DIFFICULT
--------------------------------------	--------	---------------	-----------

**EXPECTED TIME NEEDED FOR DISMANTLING AND ASSEMBLY: 70 minutes**

**TOOLS NEEDED**

 Wrench size 14	 Pliers for external seeger	 Flat screwdriver	 Allen spanner size 6	

**SPECIAL TOOLS**

 Special compass key			
------------------------------------------------------------------------------------------------------------	--	--	--

### 3.2 FILTER

In order to replace the entire filter, proceed as follows.

#### STANDARD COMPACT MCH13/16 - OPEN MODELS

Unscrew the 2 fittings of the cooling pipes using wrench size 14.

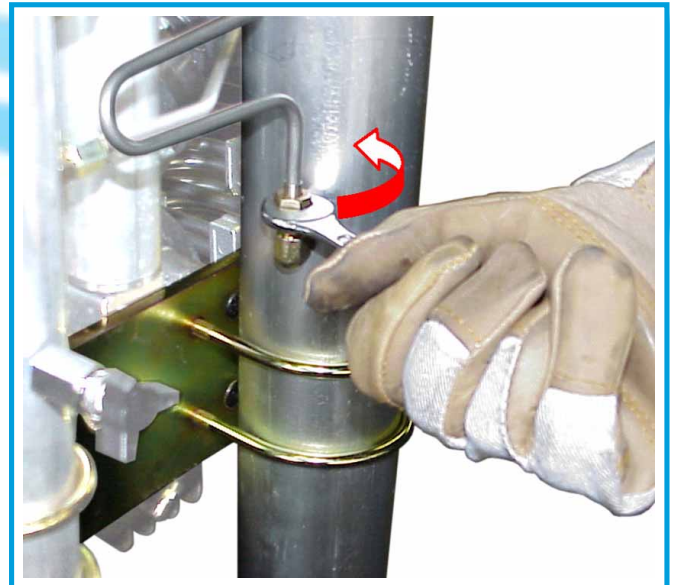

Unscrew the 4 nuts locking the 2 filter locking brackets and remove the entire filter.

For re-assembly follow the instructions above backwards.

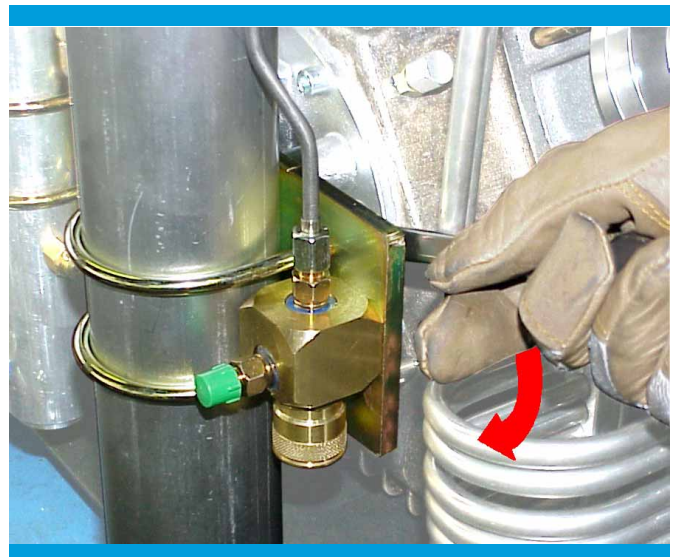

F I L T E R I N G  
S Y S T E M

**SUPER - SILENT - COMPACT  
MCH26/32 MODELS**

Lift and remove the compressor's back conveyor, in order to reach the filter.

**WARNING:  
THE CONVEYOR IS HEAVY!**



In order to do this remove the lateral panels (filter side) of the compressor following the instructions found in the relevant chapters in the previous pages.

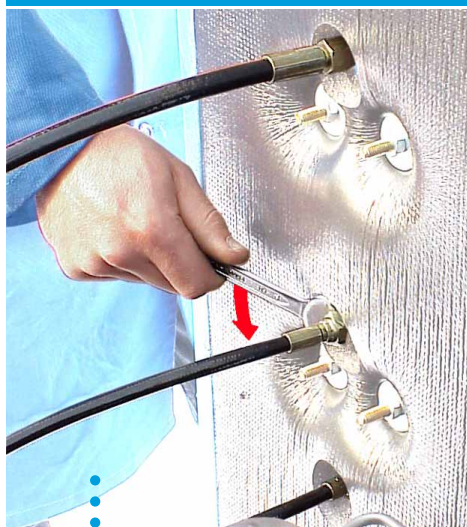

Next disconnect the 3 hoses from the fittings found on the filter (internal back panel side). The fitting of the lowest hose screwed onto the bottom cover of the filter (cod. 13-00-0160) must be unscrewed from the outside.

Unscrew the 4 nuts locking (internal to the panel) the 2 filter blocking brackets and remove the filter.

For re-assembly follow the instructions above backwards.

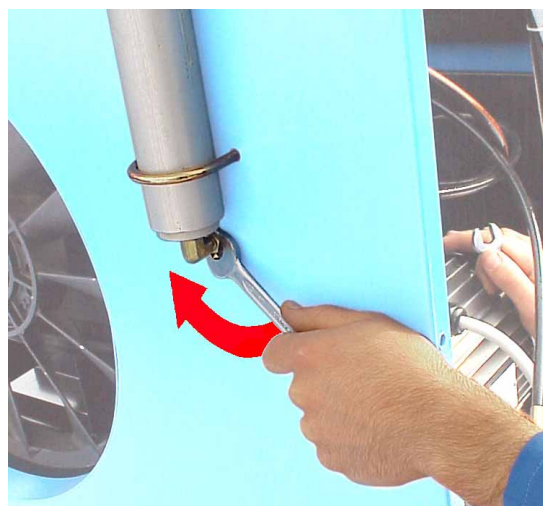

F I L T E R I N G  
S Y S T E M

MINI-SILENT MODELS

Lift and remove the compressor's back conveyor in order to reach the filter.



In order to do this remove the lateral panels (filter side) of the compressor following the instructions found in the relevant chapters in the previous pages.

Next disconnect the 3 hoses from the fittings found on the filter (internal back panel side). The fitting of the lowest hose screwed onto the bottom cover of the filter (cod. 13-00-0160) must be unscrewed from the outside.

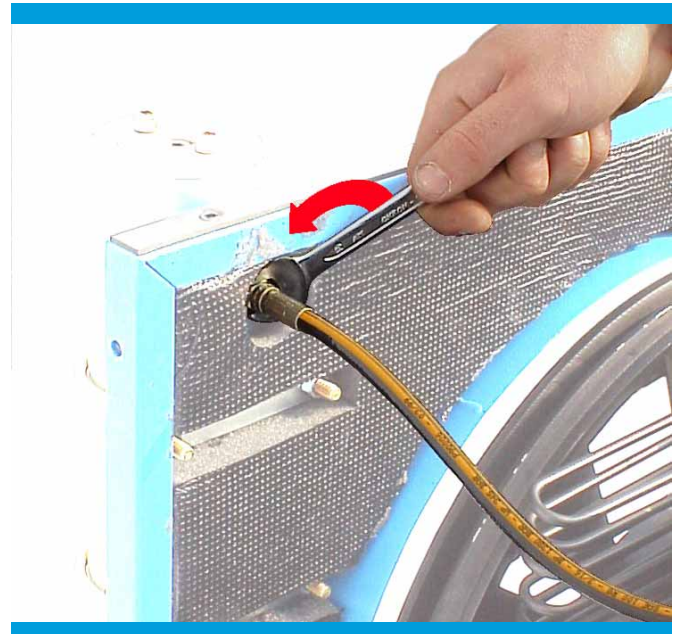

Unscrew the 4 nuts locking (internal to the panel) the 2 filter blocking brackets and remove the filter.



For re-assembly follow the instructions above backwards.

If only several of the filter's internal components need to be changed, it is not necessary to remove the filter from its seat, but proceed as follows.

Unscrew the top cover of the filter (cod. 13-00-0154) using a tool as lever (e.g. a screwdriver or a wrench), placing it between two Allen screws on the cover and unscrew.

Extract the external and internal covers.

The following will remain screwed onto the top cover: the internal cover filter (cod. 13-00-0156), its 2 O-rings (cod. 13-00-0155), the O-ring of the filter cartridge (cod. 13-00-0158) and the complete cartridge.

In order to unscrew the filtering cartridge from the internal cover simply unscrew the cover manually.

Whereas, in order to unscrew the internal cover of the filter (cod. 13-00-0156) from the top cover, unscrew the central Allen screw using Allen key size 6 mm.

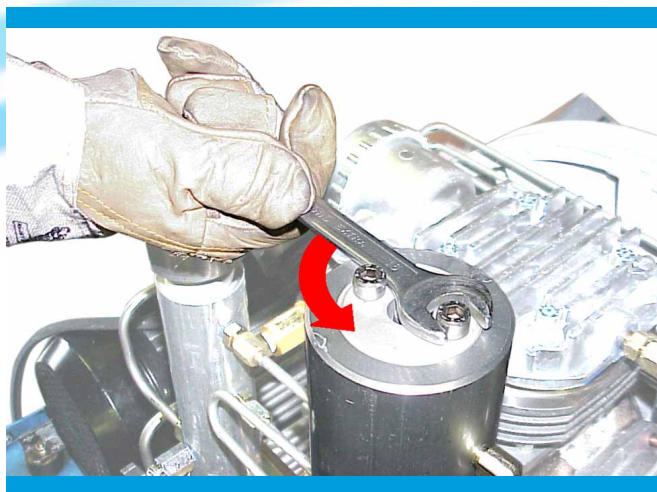

Should you need to replace the O-rings (cod. 13-00-0155) found on the internal cover or the one (cod. 13-00-0158) found on the filter, use a screwdriver to remove them.

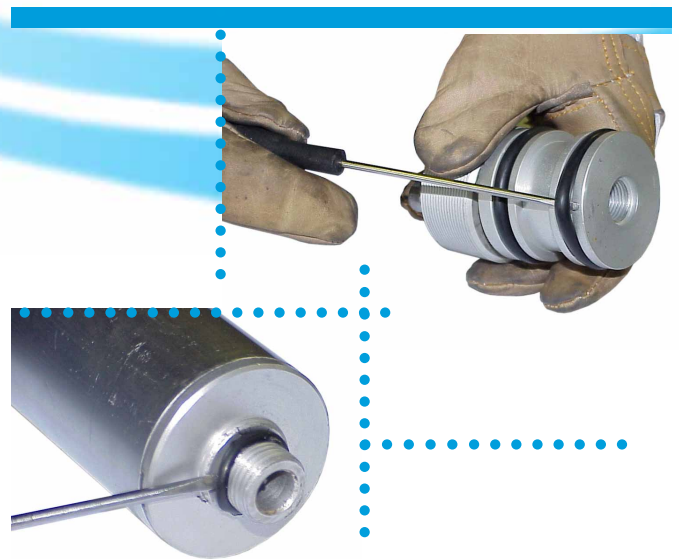

The bottom cover of the filter (cod. 13-00-0160), must be unscrewed using the special compass key.



If necessary, replace the O-ring (cod. 13-00-0155).

Some of the internal components of the filtering cartridge may also be replaced, for these specific instructions go to the following pages, if not the procedure for the re-assembly of the filter components is the following.

#### NOTE:

All filter cover threads and their O-rings must be lubricated with oil using a brush before being re-assembled.

The filter's bottom cover (cod. 13-00-0160) must be screwed back using the special compass key.

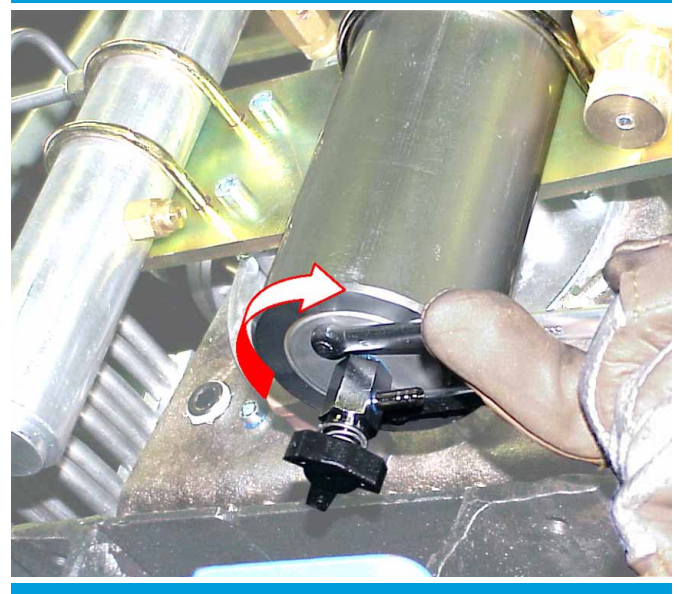

Screw the central Allen screw joining the top cover to the internal cover of the filter (cod. 13-00-0156), tightening it with Allen key size 6.



Screw the filtering cartridge onto the internal cover manually. Insert the top cover filtering group (cod. 13-00-0154) complete of internal cover and filtering cartridge, inside the filter-purifying unit (cod. 13-00-0097). Next, tighten it by inserting a lever tool (e.g. a screwdriver or a wrench) between the two Allen screws found on top of the cover.



## FILTERING CARTRIDGE

The filtering cartridge is composed of:

- 3 mesh disks (cod. 13-00-0187);
- 2 felt disks (cod. 13-00-0187);
- activated carbon cartridges;
- 1 internal spring (cod. 13-00-0188);
- 1 bottom locking clip.

In order to replace any of these components extract the filtering cartridge from the filter-purifying unit (cod. 13-00-0097) following the instruction found in the preceding chapter. Remove the locking clip with the use of pliers and then extract the components from the filtering cartridge.

For re-assembly, follow the instructions above backwards.



**PRESSURE MAINTENANCE VALVE**

<b>LEVEL OF SERVICING DIFFICULTY</b>	SIMPLE	MEDIUM	DIFFICULT
--------------------------------------	--------	--------	-----------



**EXPECTED TIME NEEDED FOR DISMANTLING AND ASSEMBLY: 30 minutes**

**TOOLS NEEDED**

 Wrench size 14				

**SPECIAL TOOLS**

--	--	--	--

### 3.3 PRESSURE MAINTENANCE VALVE

In order to replace the pressure maintenance valve entirely follow these operations:

Unscrew the top fitting going to the valve unit using wrench size 14.



Unscrew the elbow fitting connecting the front hose to the valve unit.



Unscrew the 2 Allen screws locking the valve to the support plate and remove the entire maintenance valve.

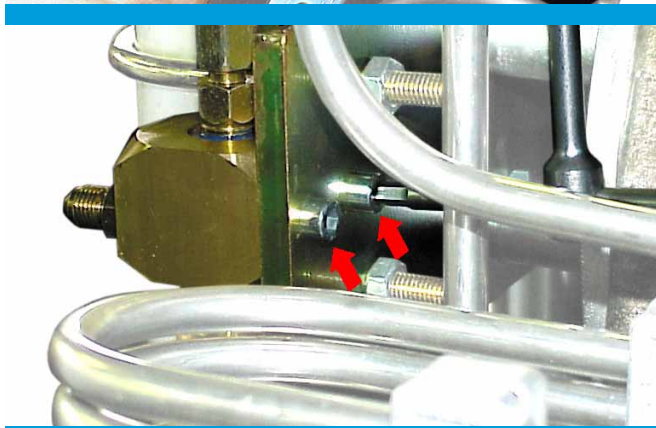

For re-assembly, follow the instructions above backwards.

Should only several of the internal pressure maintenance valve components need to be replaced, it is not necessary for the filter to be removed from its seat. Proceed as follows:

Unscrew the bottom cap (cod. 13-00-0151) of the pressure maintenance valve manually. Inside you will find:

- series of Belleville washers (cod. 13-00-0150);
- 1 pressure maintenance valve small piston (cod. 13-00-0149);
- 1 pressure maintenance valve steel sphere (cod. 13-00-0148).

For re-assembly, follow the instructions above backwards, taking care to the order of the components and the positioning of the Belleville washers which must be opposite to each other (see exploded view opposite).



**FINAL SAFETY VALVE**

**LEVEL OF SERVICING DIFFICULTY**

SIMPLE

MEDIUM

DIFFICULT



**EXPECTED TIME NEEDED FOR DISMANTLING AND ASSEMBLY: 30 minutes**

**TOOLS NEEDED**



Wrench size 17

**SPECIAL TOOLS**

--	--	--	--

### 3.5 FINAL SAFETY VALVE

**Check:**

The final safety valve must also be replaced entirely if servicing is carried out near a pumping unit revision.

Unscrew the entire valve using wrench size 17 and replace it.

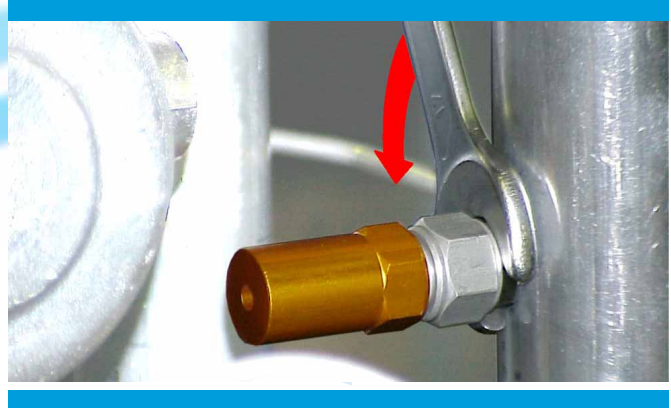

### RE-ASSEMBLY AND SETTING

- a) Using wrench size 17 screw the final safety valve onto the condensate separator (cod. 13-00-0096) and put a couple of drops of the thread locking product on the fitting thread.

Replacement of the final safety valve always means re-setting it. To do so, proceed as follows:

- b) Start the compressor. If it has a pressure gauge (cod. SC00310) set it to maximum pressure. Check the safety valve's discharge pressure and should it be above or below the desired one, screw or unscrew respectively the cover (cod. 13-00-0165) with the system totally depressurised.

**NOTE:**

Do not set the safety valve if the system's internal pressure is above 50 bar.

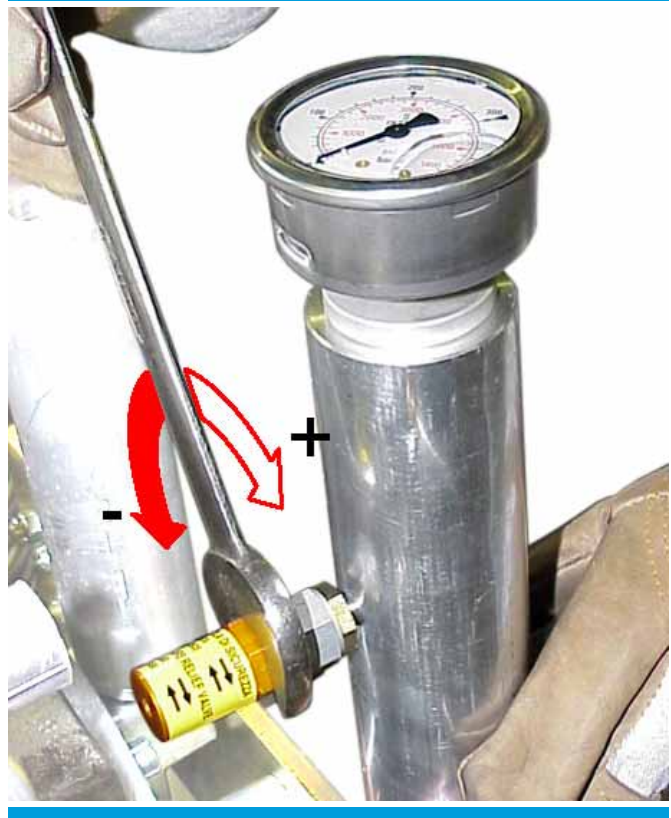
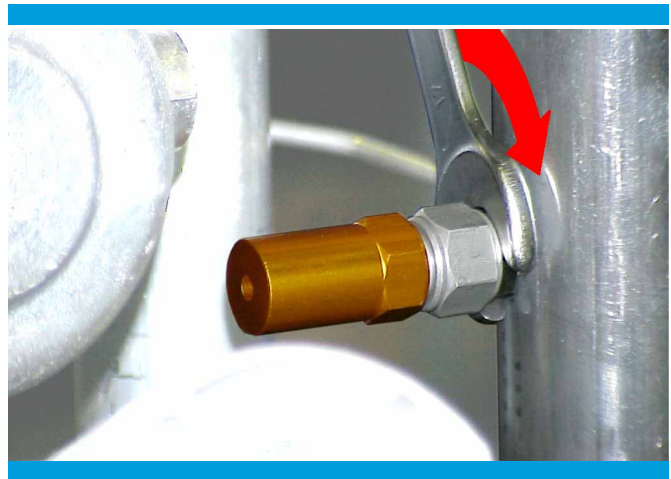

- c) Should the pressure not be the desired one (it may vary also based on the specific compressor model bought; see technical data found on the compressor's instructions manual), air must be discharged from the separator through the appropriate hand-wheel until the reading is below 50 bar.
- d) Set the valve with the condensate discharge hand-wheel (cod. 13-00-00164) open, using the adjustment cover (cod. 13-00-0165) of the safety valve, referring to the instructions found on the pictogram found directly on the cover. Please consider that screwing the cover on the pressure rises and unscrewing the cover it diminishes.
- e) Close the discharge condensate hand-wheel (cod. 13-00-00164) and take a new reading on the pressure gauge. If the pressure is still not the desired one, repeat the operation starting from point c) until you reach the desired condition.



Once the set pressure has been reached, the final safety valve starts to discharge: this is normal.

If only several internal components of the final safety valve are being changed, after having removed it from its seat as described above, proceed as follows.

Unscrew the safety valve unit (cod. 13-00-0169) from the fitting (cod. 13-00-0173) and from the regulating cover (cod. 13-00-0165). Inside you will find:

- 1 safety valve O-ring (cod. 13-00-0172);
- 1 safety valve spring seat (cod. 13-00-0171);
- 1 safety valve Nylon seat (cod. 13-00-0170);
- 1 safety valve small piston O-ring (cod. 13-00-0168);
- 1 safety valve small piston (cod. 13-00-0167);
- 1 safety valve spring (cod. 13-00-0166).



For re-assembly, follow the instructions above backwards, taking care to the order of the components and the positioning of the Belleville washers which must be opposite to each other (see exploded view on the side). Using a brush apply grease to the O-rings and to the fitting thread and valve unit.

**INSTRUMENTS**

<b>LEVEL OF SERVICING DIFFICULTY</b>	SIMPLE ●	MEDIUM	DIFFICULT
--------------------------------------	-------------	--------	-----------

**EXPECTED TIME NEEDED :**

**TOOLS NEEDED**

**SPECIAL TOOLS**

--	--	--	--

**ELECTRIC PANEL**

<b>LEVEL OF SERVICING DIFFICULTY</b>	SIMPLE	MEDIUM	DIFFICULT
--------------------------------------	--------	--------	-----------

**EXPECTED TIME NEEDED :**

**TOOLS NEEDED**

 Wrench size 10	 Wrench size 14	 Allen key size 6	 Allen key size 8	 Round-nose pliers
 Philips screwdriver	 Flat screwdriver			

**SPECIAL TOOLS**

--	--	--	--

## 5 CONTROL PANEL

1. **Green/Red light button metallic IP67**  
Brand SIEMENS  
Permanent Current Ith = 10A
2. **Yellow matt metallic button IP67**  
Brand SIEMENS  
Permanent current Ith = 10A
3. **Hour counter 48x48**  
V alim. = 230V 50Hz OR V alim. = 230V 60Hz  
Brand ISKRA
4. **Automatic switch 5SX2101-7**  
Brand SIEMENS  
Pint. = 6KA class 3
5. **Automatic switch 3RV1021-4AA10**  
Brand SIEMENS  
Setting 11-16A Pint. = 100KA
6. **Automatic switch 3RV1011-1JA10**  
Brand SIEMENS  
Setting 7-10A Pint = 100KA
7. **Transformer 63VA**  
Brand CE OR VM eng.  
Vprim. = 0-230-400 Vsec. = 0-24
8. **Transformer 150VA**  
Brand CE OR VM eng.  
Vprim. = 0-230-400 Vsec. = 0-24
9. **Electronic timer**  
Brand CDC  
Two stroke cycles which can be set separately  
Valim. = 115-230V ac
10. **Contactors 3RT1024-1AP20**  
Brand SIEMENS  
5,5Kw 3POLI Valim.= 400V ac Vbob. = 230V 50/60Hz
11. **Contactors 3RT1016-1AP01**  
Brand SIEMENS  
4Kw 3POLI 1contact n.o. Valim. = 400V ac  
Vbob. = 230V 50/60Hz

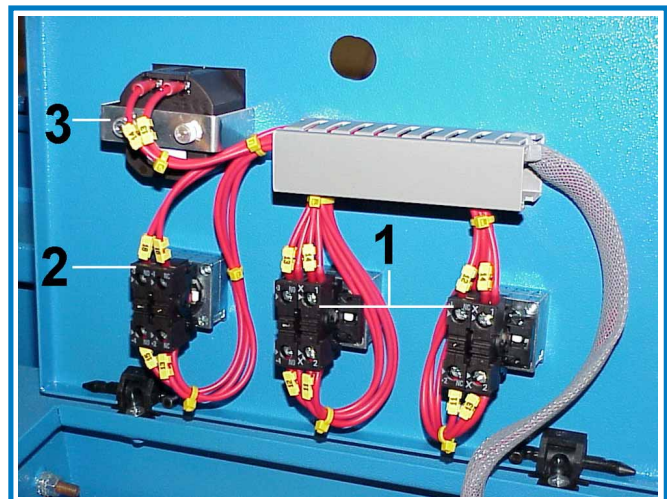
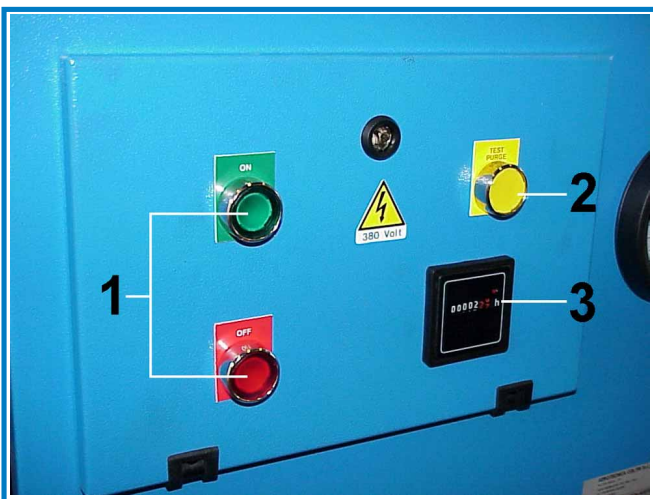
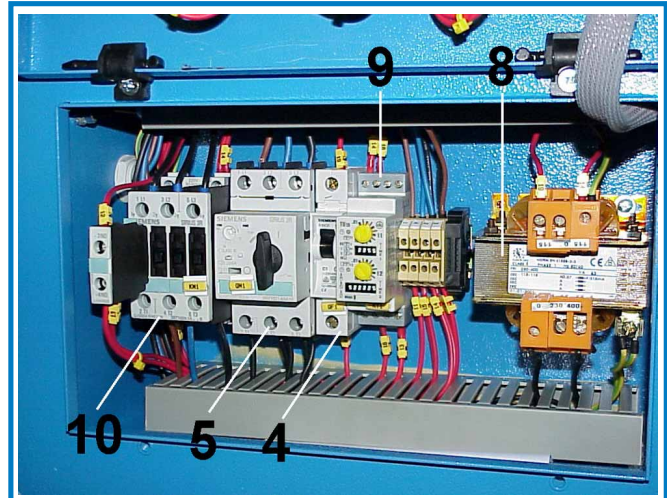
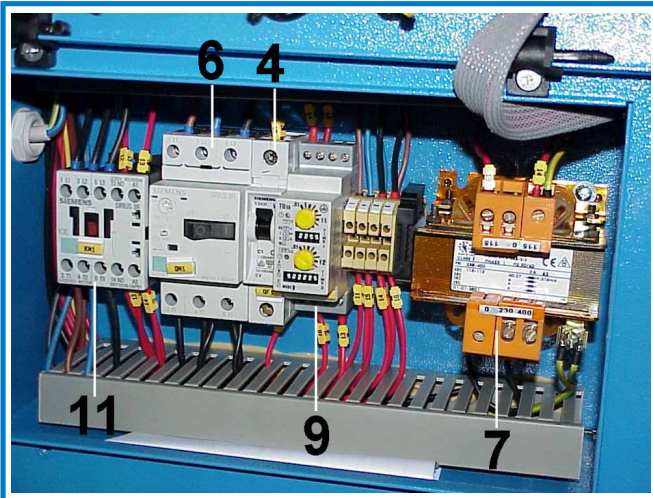

5.1 DIAGRAMS

5.1.1 "STANDARD" SERIES COMPRESSORS

SERVICE MANUAL

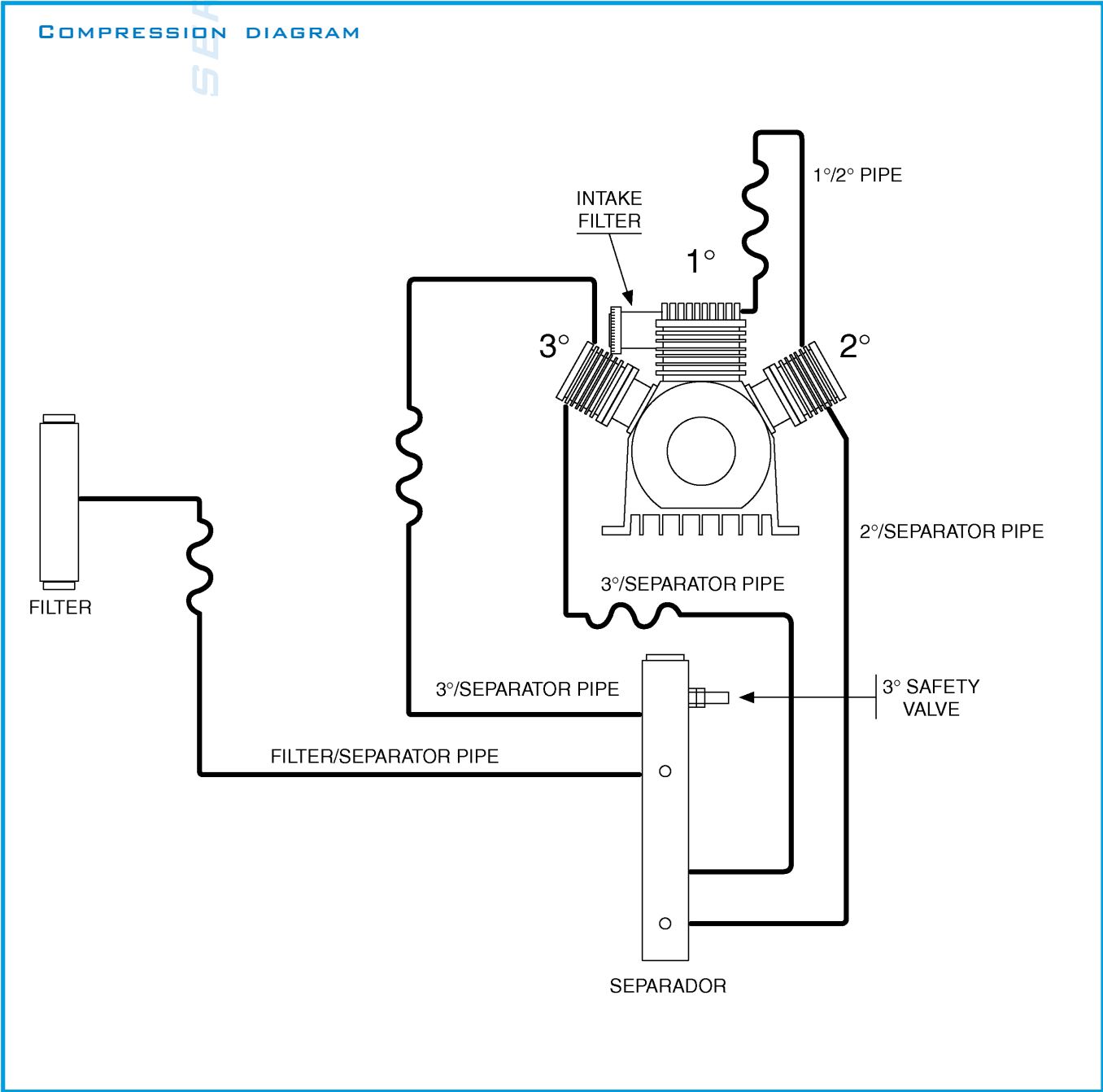

COMPRESSION DIAGRAM

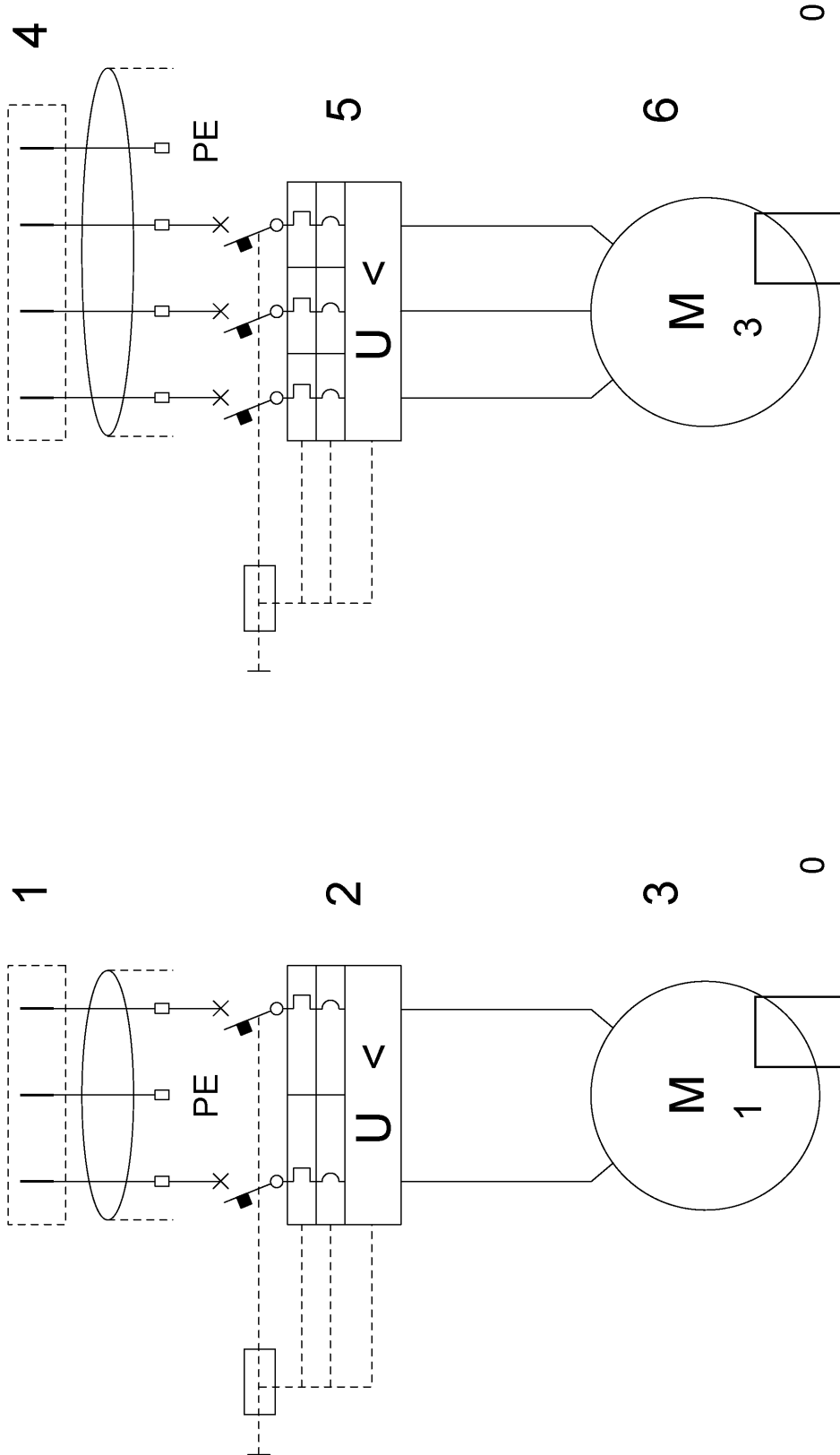



### 5.1.2 "COMPACT" SERIES COMPRESSORS

#### Compression diagram

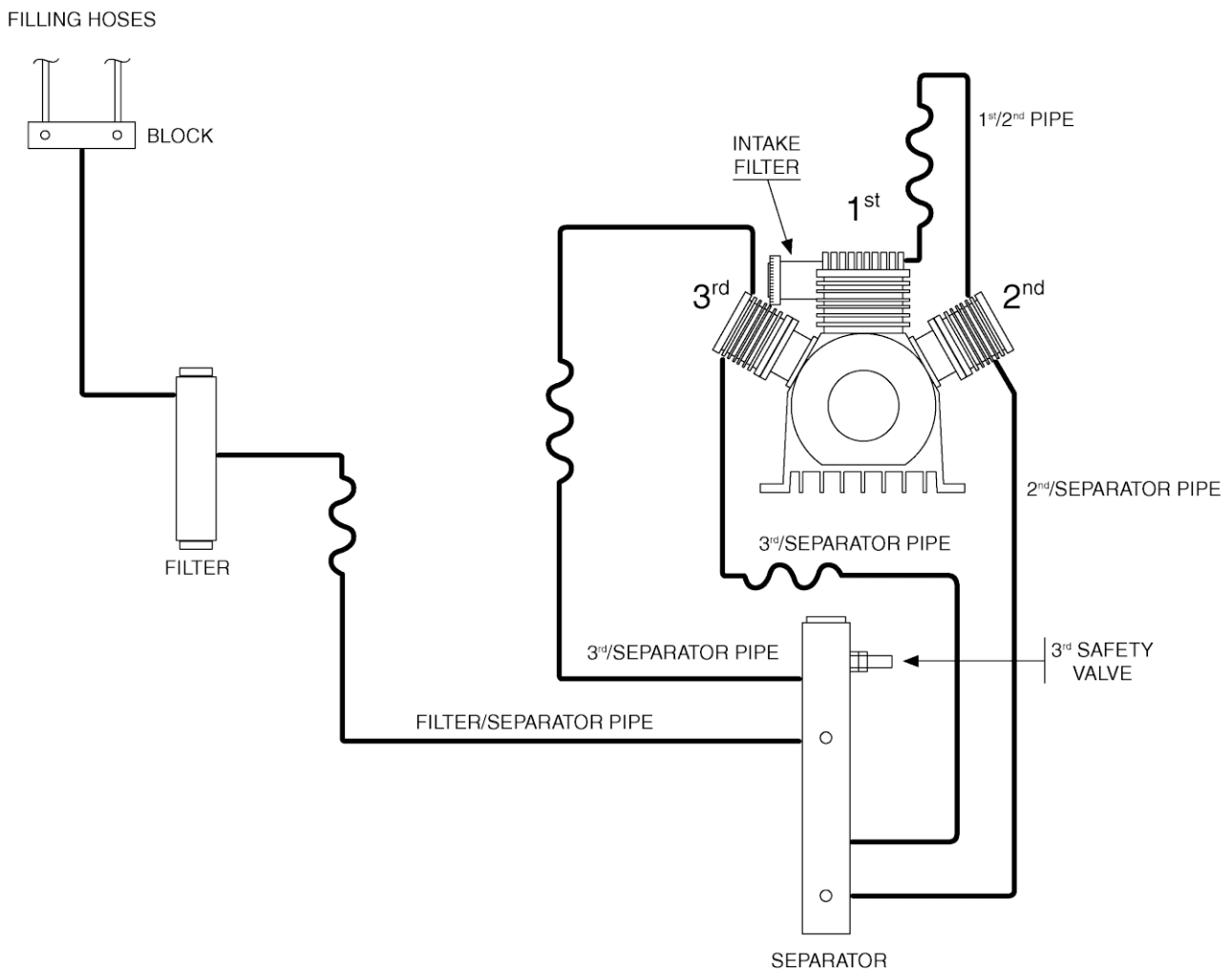

Electrical diagram

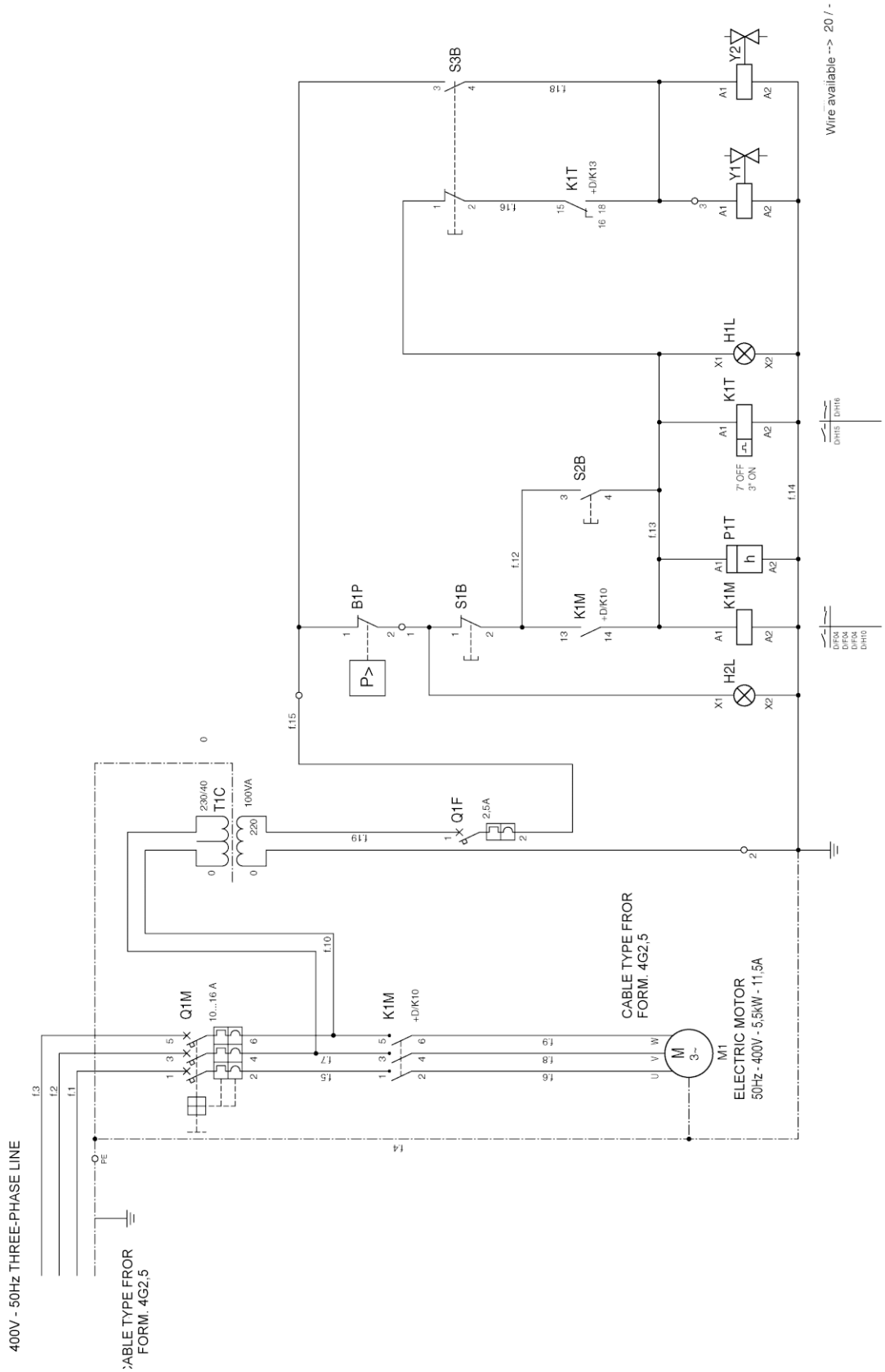

**“MCH 26-32/ET COMPACT” SERIES COMPRESSORS**

THREE PHASE ELECTRICAL LINE WITHOUT NEUTRAL WIRE

220V - 63 A  
380V - 25 A

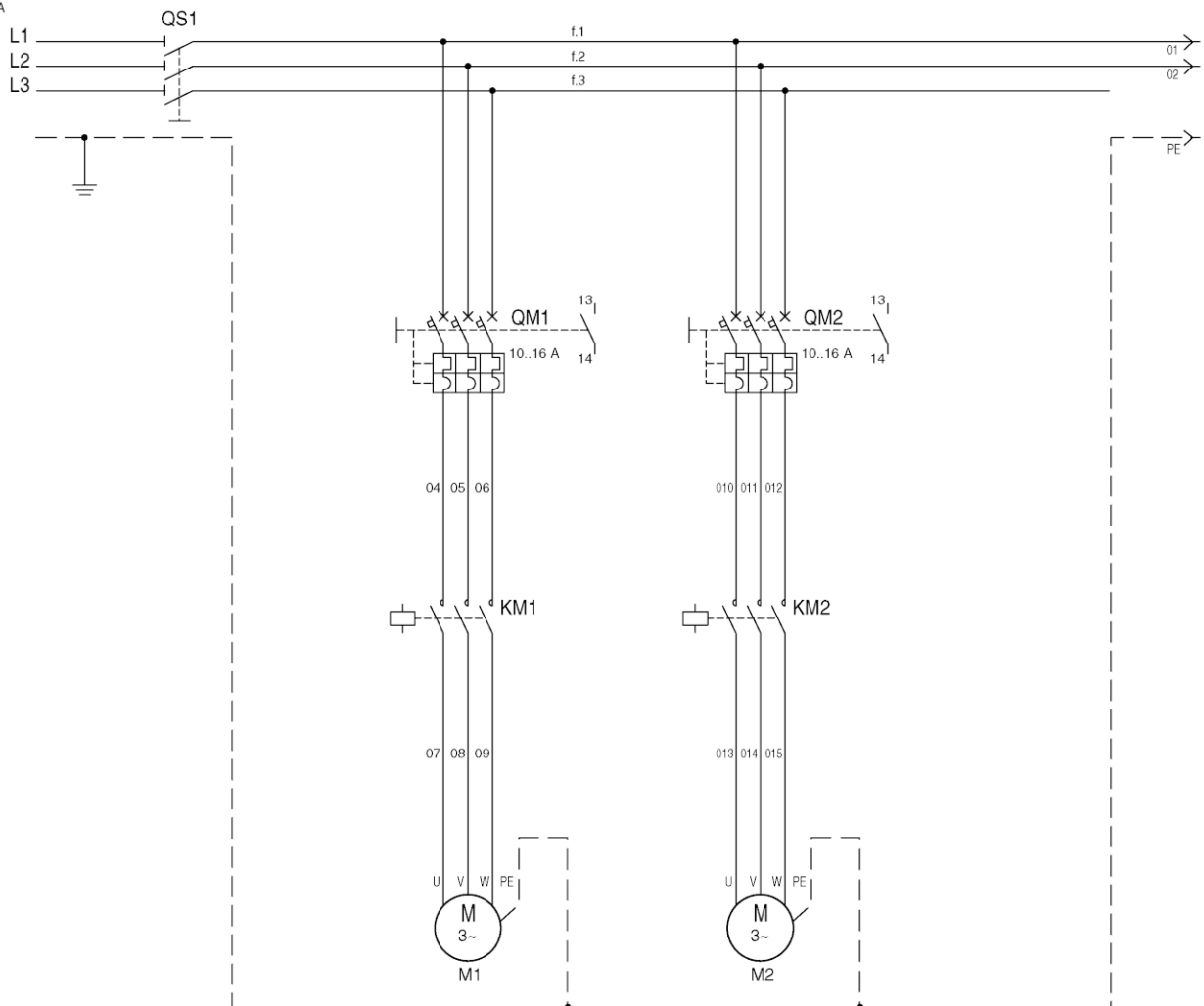

FOR VERSION MCH26/ET COMPACT:  
400V-50Hz (cod. SC000284)  
230V-50Hz (cod. SC000285)  
230V-60Hz (cod. SC000286)  
2x4Kw-5,5HP

FOR VERSION MCH32/ET COMPACT:  
400V-50Hz (cod. SC000287)  
230V-50Hz (cod. SC000288)  
230V-60Hz (cod. SC000289)  
2x5,5Kw-7,5HP

“MCH 26-32/ET COMPACT” SERIES COMPRESSORS

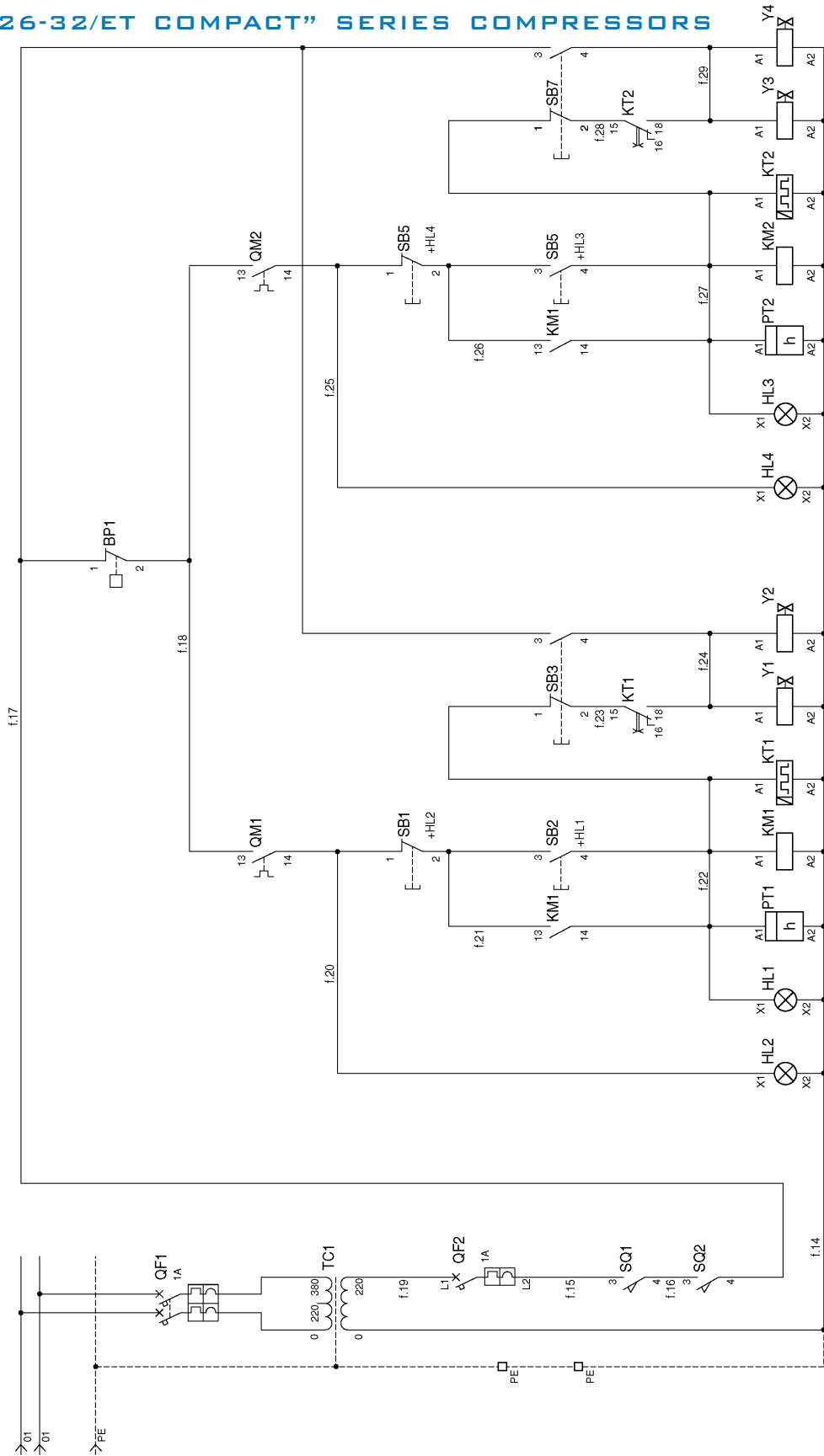

**COMPONENTS FOR "COMPACT" SERIES COMPRESSORS**

POS.	LEGEND
	<b>GENERAL</b>
QS1	MAIN SWITCH
QF1	PRIMARY PROTECTION AUXILIARY SWITCH
TC1	AUXILIARY TRANSFORMER (380/220 OR 220/220)
QF2	SECONDARY PROTECTION AUXILIARY SWITCH
BP1	PRESSURE SWITCH
SQ1	MICRO SAFETY HATCH
SQ2	MICRO SAFETY HATCH
	<b>MOTOR M1</b>
QM1	MOTOR THERMAL PROTECTION SWITCH
KM1	MOTOR CHECK CONTACTOR
M1	MOTOR
SB1	STOP BUTTON
SB2	START BUTTON
SB3	DISCHARGE BUTTON
HL2	MOTOR READY TO START INDICATOR (GREEN)
HL1	START INDICATOR (RED)
PT1	HOUR METER
KT1	AIR INTAKE-DISCHARGE TIMER
Y1	AIR INTAKE VALVE COIL
Y2	DISCHARGE VALVE COIL
	<b>MOTOR M2</b>
QM2	MOTOR THERMAL PROTECTION SWITCH
KM2	MOTOR CHECK CONTACTOR
M2	MOTOR
SB5	STOP BUTTON
SB6	START BUTTON
SB7	DISCHARGE BUTTON
HL4	MOTOR READY TO START INDICATOR (GREEN)
HL3	START INDICATOR (RED)
PT2	HOUR METER
KT2	AIR INTAKE-DISCHARGE TIMER
Y3	AIR INTAKE VALVE COIL
Y4	DISCHARGE VALVE COIL

5.1.3 "MINI E SUPER SILENT" SERIES COMPRESSORS

SERIES COMPRESSORS

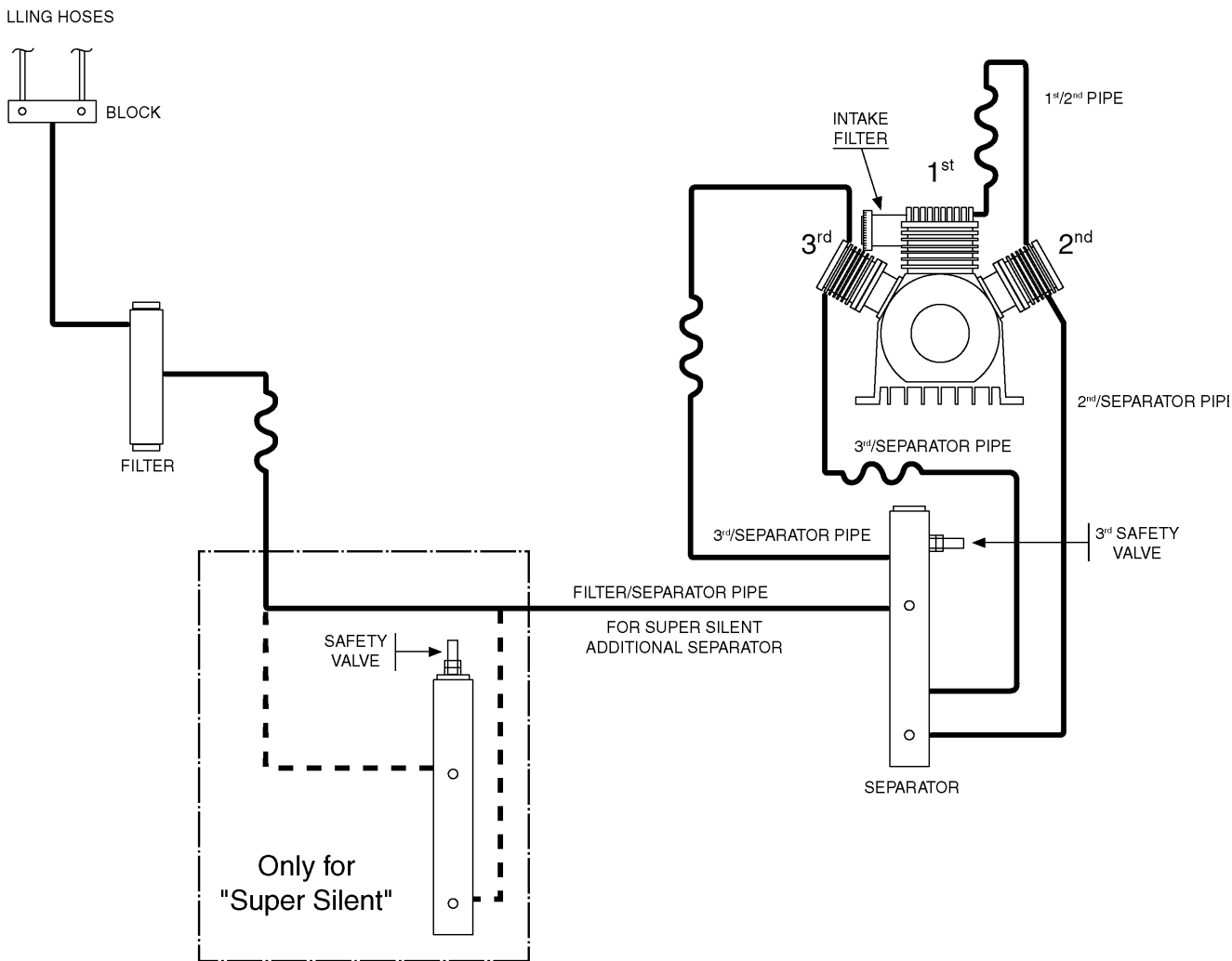

**Electrical diagram**

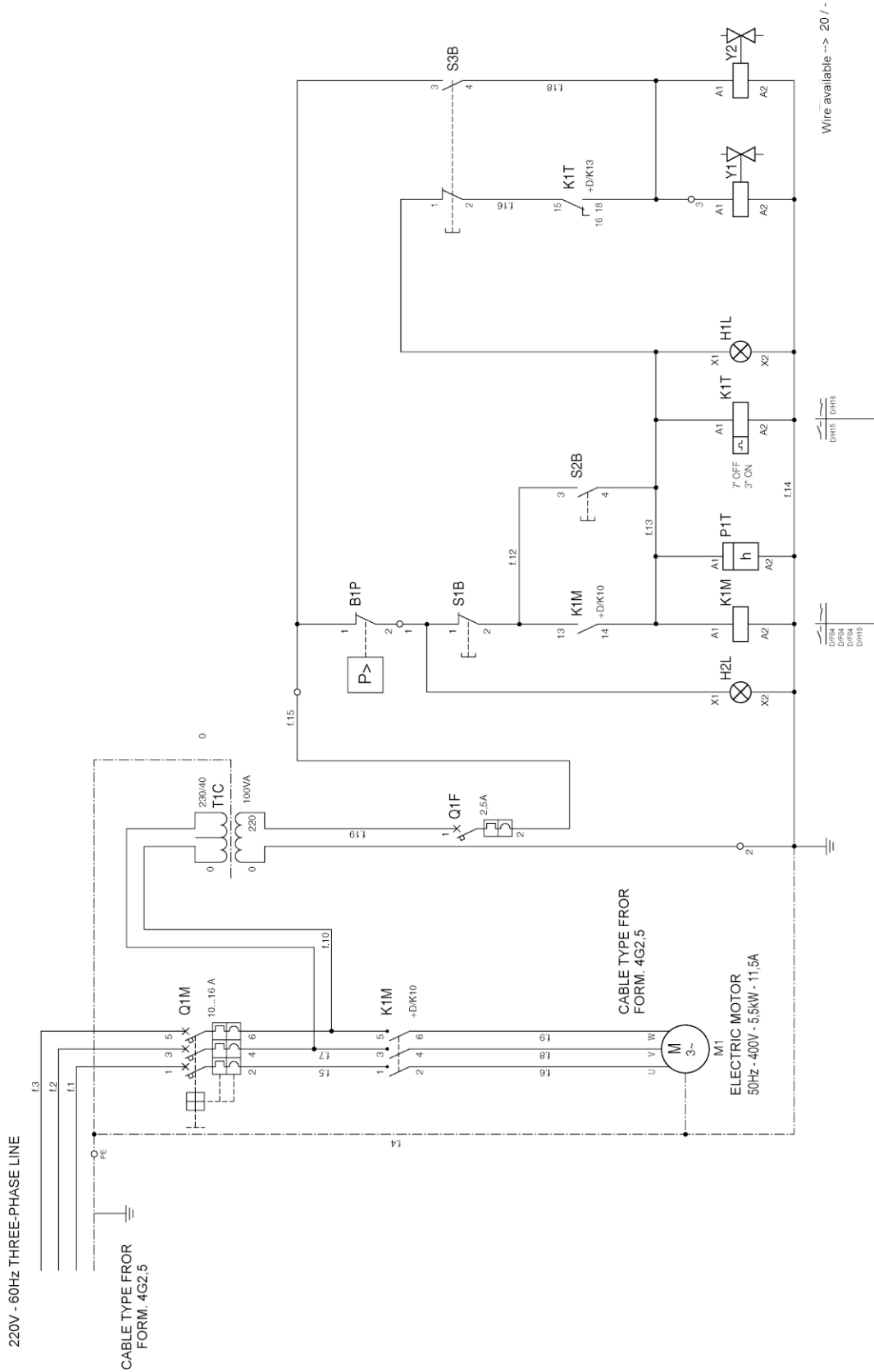

5.1.4 "OPEN" SERIES COMPRESSORS

SERIES COMPRESSORS

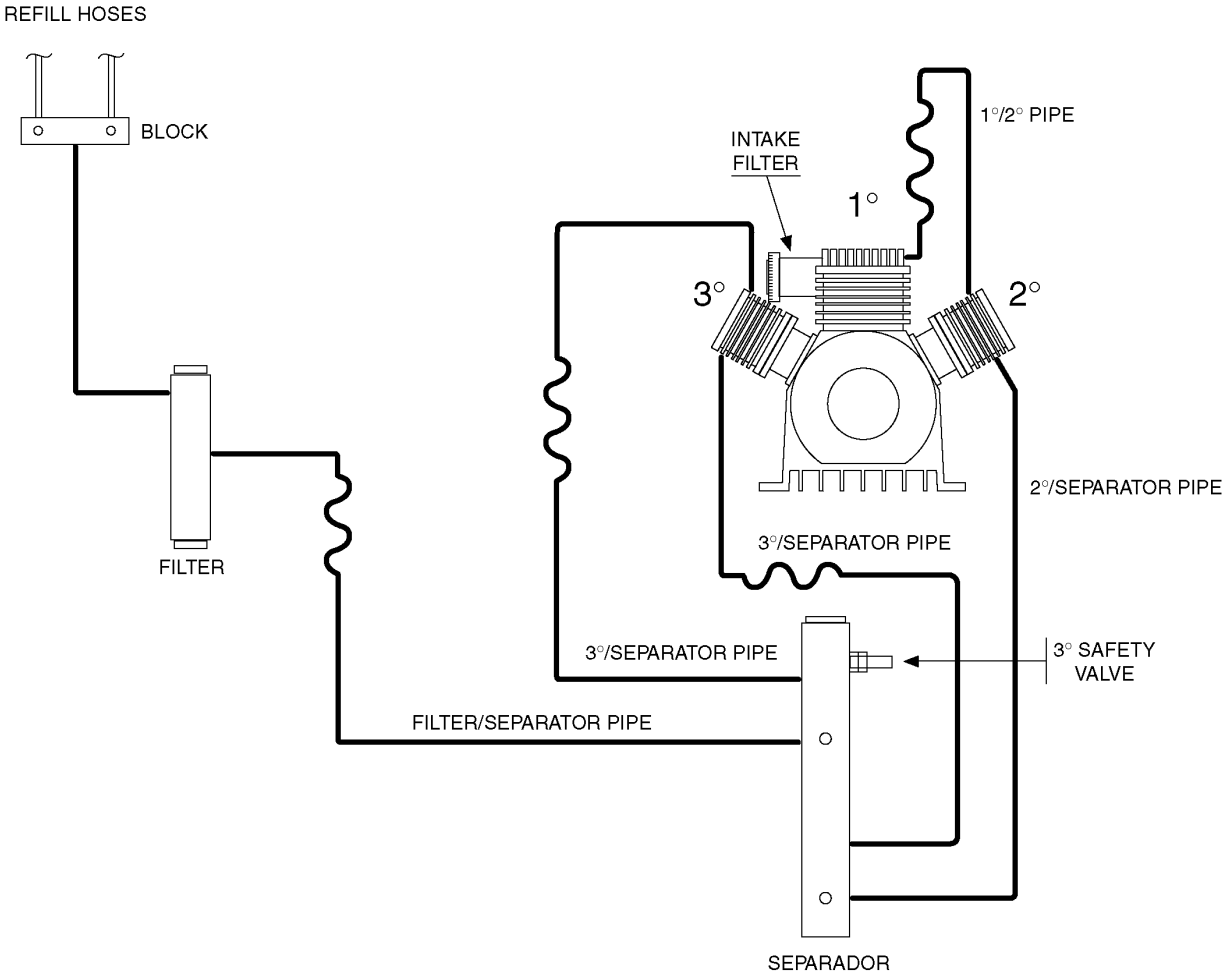

**Electrical diagram**

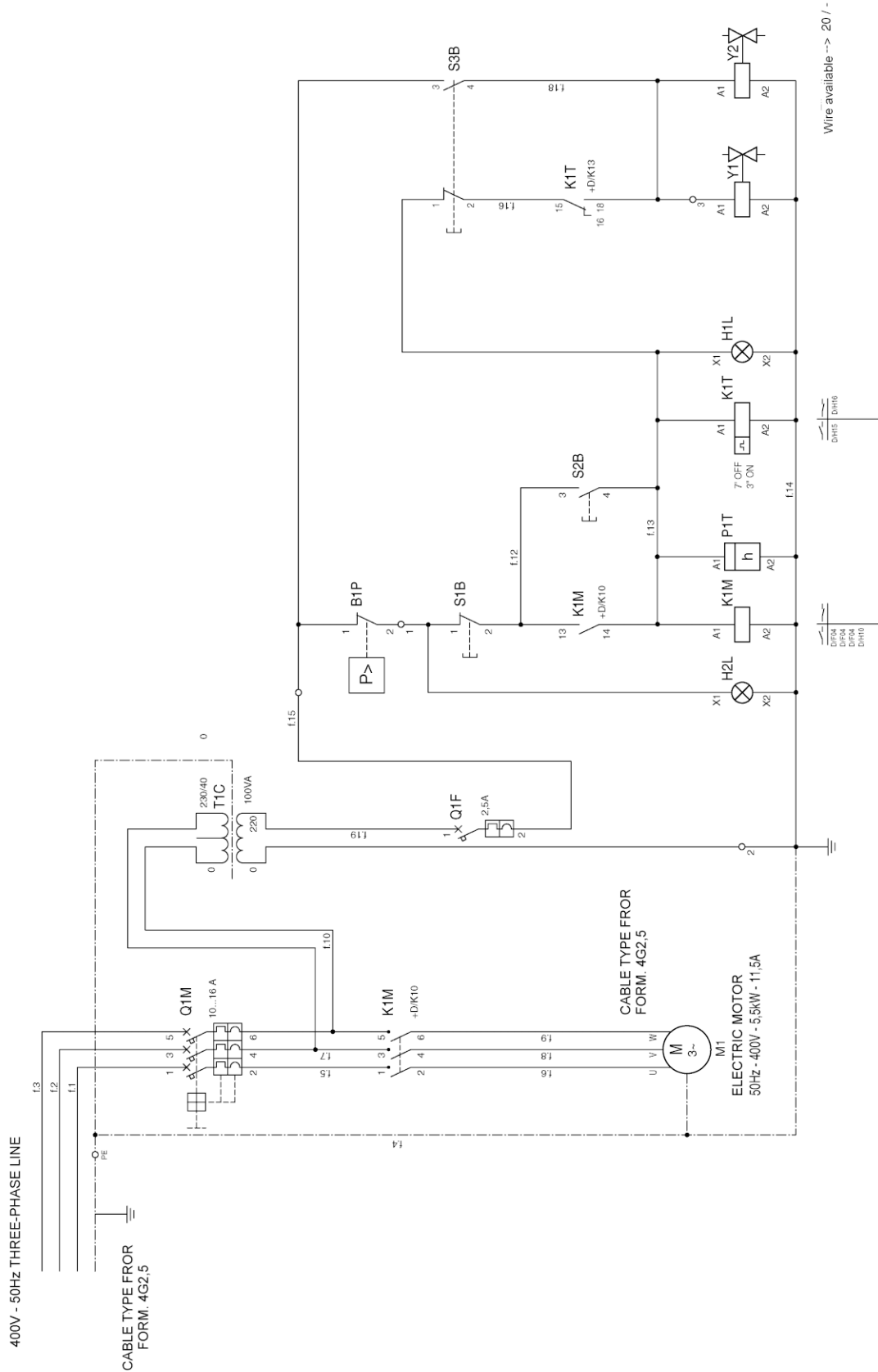

## 6.1 TUBE SIDE ASSEMBLY TORQUES

Clamp tube flare between sleeve and nose of fitting body by screwing nut on finger tight.

Tighten with wrench for dependable metal-to-metal joint (see assembly torque table under).

Triple-Lok fitting is easy to dis-assemble and may be reassembled repeatedly, always giving leakproof and dependable connection.

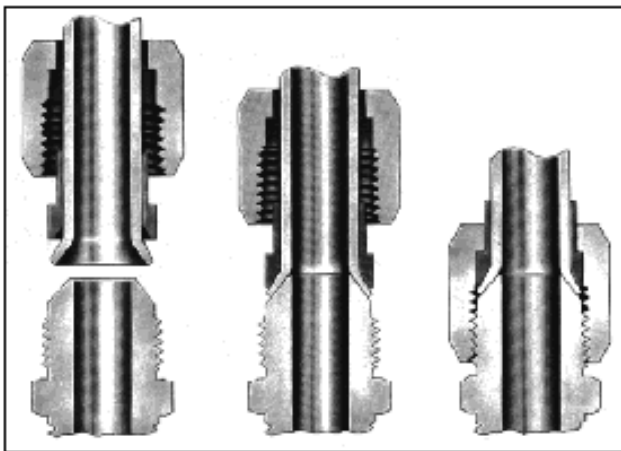

Metric tube mm	Inch tube in.	JIC SAE Thread	Assembly torque		FFFT method	
			Nm*	0 +10%	TT	ET
6	1/4	7/16-20	15 ± 1	15	2	2
8	5/16	1/2-20	20 ± 1	20	2	2
10	3/8	9/16-18	28 ± 2	30	1.1/2	1.1/4
12	1/2	3/4-16	62 ± 2	60	1.1/2	1
14		7/8-14	80 ± 5	75	1.1/2	1
15		7/8-14	80 ± 5	75	1.1/2	1
16	5/8	7/8-14	80 ± 5	75	1.1/2	1
18		1.1/16-12	110 ± 5	110	1.1/4	1
20	3/4	1.1/16-12	110 ± 5	110	1.1/4	1
22	7/8	1.3/16-12	141 ± 5	135	1	1
25	1	1.5/16-12	160 ± 5	155	1	1
28		1.5/8-12	225 ± 5	215	1	1
30		1.5/8-12	225 ± 5	215	1	1
32	1.1/4	1.5/8-12	225 ± 5	215	1	1
35		1.7/8-12	270 ± 15	250	1	1
38	1.1/2	1.7/8-12	270 ± 15	250	1	1
42		2.1/4-12		290	1	1
50	2	2.1/2-12	360 ± 20	340	1	1

TT : Tube – Tube

ET : Swivel nut or hose connection \* Tolerance +10%-0%  
Steel parts unlubricated.

For stainless steel use upper tolerance.

## FLATS FROM FINGER TIGHT (FFFT) METHOD

After hand tightening the joint, make a longitudinal mark on one of the flats of hex and continue it on the body hex with a permanent type ink marker as shown opposite.

Then tighten the joint further by the number of flats as shown in table (FFFT). Now mark the body hex opposite the displaced mark.

These marks serve two important functions:

1. Displaced marks serve as a quick quality assurance check that the joint has been properly tightened.
2. Second mark on the body serves as a proper tightening position after a joint has been loosened.

This method is slower than the torque method – but it has three distinct advantages over the torque method:

1. It eliminates the problems associated with different plating combinations.
2. It provides a very quick visual check for proper joint tightening.
3. It does not require special tools (torque wrench crow foot spanner socket).

**Note:** Port thread assembly torques are mentioned in the charts page M21 to M23.



Finger tight position with initial mark.



Fully tightened positioned with displaced mark example shows a nut at 1 1/2 flats from finger tight.

**NOTES:**

1. Assembly torques shown in chart are for non-lubricated carbon steel components.
2. For brass fittings, contact Parker for the recommended assembly torques.
3. Recommended assembly torques are for connections consisting of all Parker manufactured fittings.

## 6.2 "COMPACT" PROGRAMMED MAINTENANCE

### GENERAL NOTES

#### WARNING

All the routine and additional maintenance operations must be carried out with the machine at a standstill (the compressor at a standstill) and with the power supply disconnected.

The residue pressure in the machine (pump circuit) must be eliminated.

Any operation carried out on the machine must only be undertaken having read and carefully applied the regulations listed in Chapter 4 "Precautions for use and maintenance". To keep the machine in good working condition, it must be cleaned very thoroughly.

Having been designed and built according to the most advanced technological criteria, this type of filling station requires very limited preventive and routine maintenance operations.

However, it is essential to follow the indications given in this chapter very carefully and to follow the intervals between operations as suggested.

During the guarantee period no responsibility is taken for any damage or operating faults due to a failure to comply with the regulations in force.

The following paragraph enables all the routine and additional maintenance operations carried out on the machine to be recorded.

This paragraph should be filled in carefully and any operations carried out to solve problems should also be reported.

### PREVENTIVE MAINTENANCE (TABLE 1)

**Table 1**

		INTERVALS										
		X	1 day	15 min	30 min	25 h	50 h	125 h	250 h	500 h	1000 h	5000 h
1	Replace the activated carbon cartridge, see par. 11.7											
2	Check the compressor oil level					○						
3	First compressor oil change					●						
4	Change compressor oil								●			
5	Intake filter cartridge					○		●				
6	Operation of the end safety valve					○						
7	Operation and tightness of the filling valve					○						
8	Alignment of the compressor needle with the ○ when the compressor is depressurized					○						
9	Tightening of the cooling pipes							○				
10	Tightening of the connecting pipes							○				
11	Belt tension and wear								○		●	
12	Hose replacement										●	
13	2 <sup>nd</sup> and 3 <sup>rd</sup> stage intake and discharge valves									●		
14	Internal cleaning of end separator								○			
15	Tightening of all the screws								○			
16	General cleaning								○			
17	Replacement of the external casing of the strainer filter											●
18	Replacement of 1 <sup>st</sup> stage head										●	

●= replacement

○= inspection, cleaning

**CHANGING THE LUBRICANT OIL  
(TABLE 2)**

The quantity of oil for the lubrication of the pump unit must be checked every 25 hours.

To carry out this operation, see chapter 8 "Start up".

The oil must be changed every 250 operating hours or yearly.

When changing the oil, do not use a mixture of different oils.

The oil must have the following characteristics:

**Table 2**

<b>Sump capacity</b>	cu.cm. litres/gallons	1500 1.5/0.476
<b>Recommended oils</b>		AEROTECNICA COLTRI SPECIAL MINERAL OIL AEROTECNICA COLTRI SPECIAL SYNTHETIC OIL MOBIL SPECIAL 20 W 50 MOBIL RARUS 827-829 ANDEROL 755 SYNTHETIC
<b>Viscosity of the oil</b>	summer winter	above +10 °C (50 °F) SAE 20 W/40 from +10 °C to -15 °C (50° to 5 °F) SAE 10 W below -15 °C (5 °F) SAE 5 W
<b>Maximum tilt of the compressor with the oil level at maximum</b>	degrees	~ 5

To change the oil, proceed as follows:

- 1 Use a basin with a minimum capacity of 2.5 lt. capacity under the oil discharge tap
- 2 Unscrew the hexagonal closing cap located in front of the oil discharge.

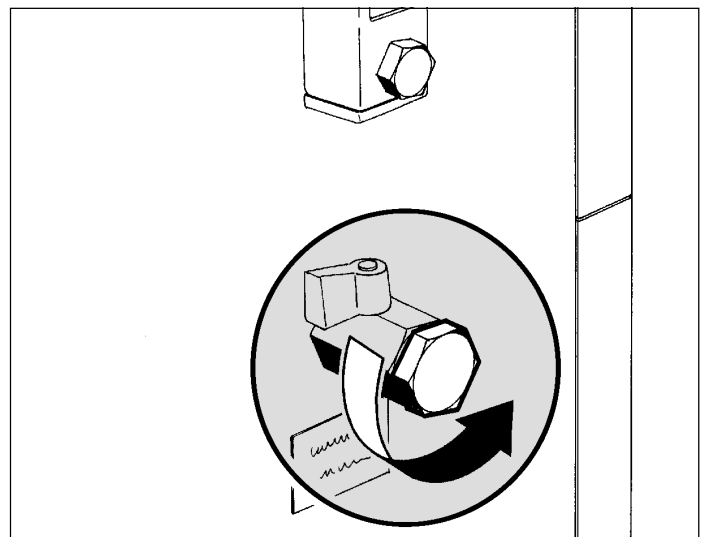

- 3 Open the oil discharge two taps and discharge all the oil in the sumps.

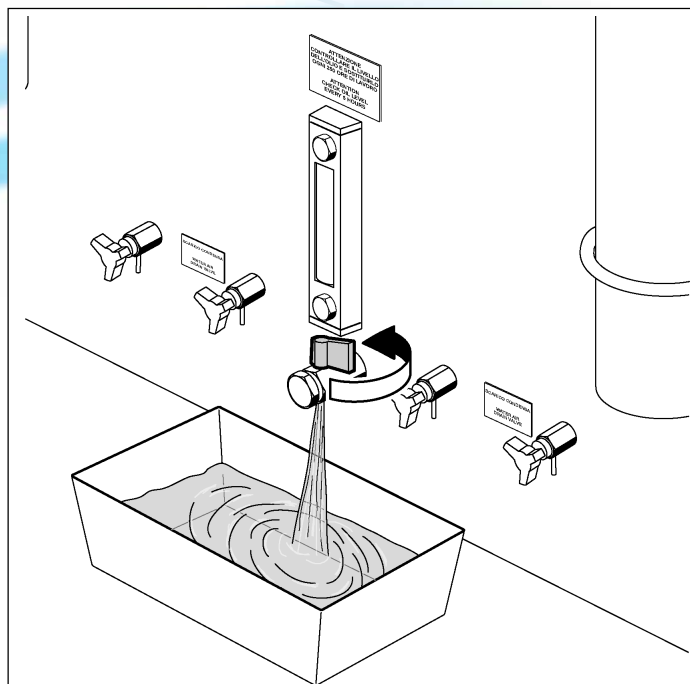

- 4 Open the oil discharge two taps (Fig. 73) and discharge all the oil in the sumps.
- 5 Carry out the filling operations as described in chapter 8 "Start up".

## WARNING

To dispose of waste oils follow the instructions given in chapter 10.2 "Disposal of waste products" with great care.

**CHECKING THE DRIVE BELT**

The drive belt is checked by measuring the yield of the same. This operation must be carried out every 250 machine operating hours as described below:

- 1 Remove the protective cover as shown in figures 74 and 75, by unscrewing the fixing screws.

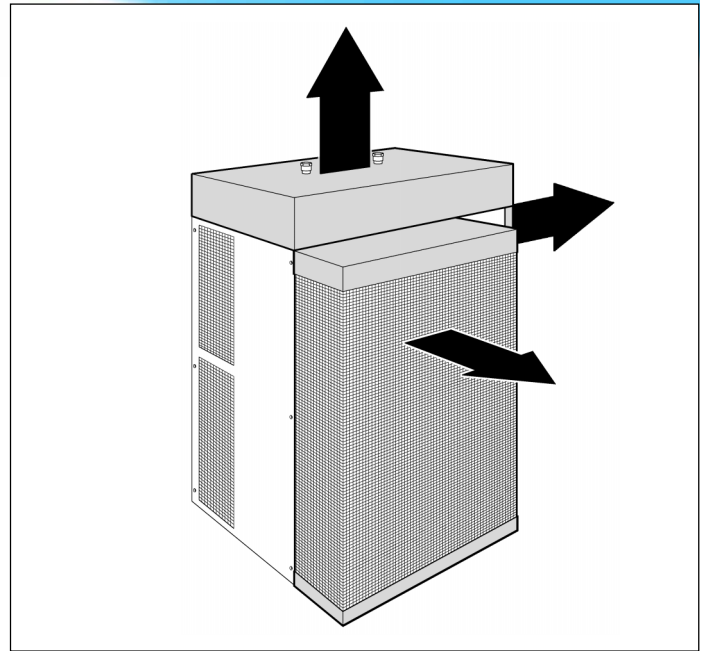
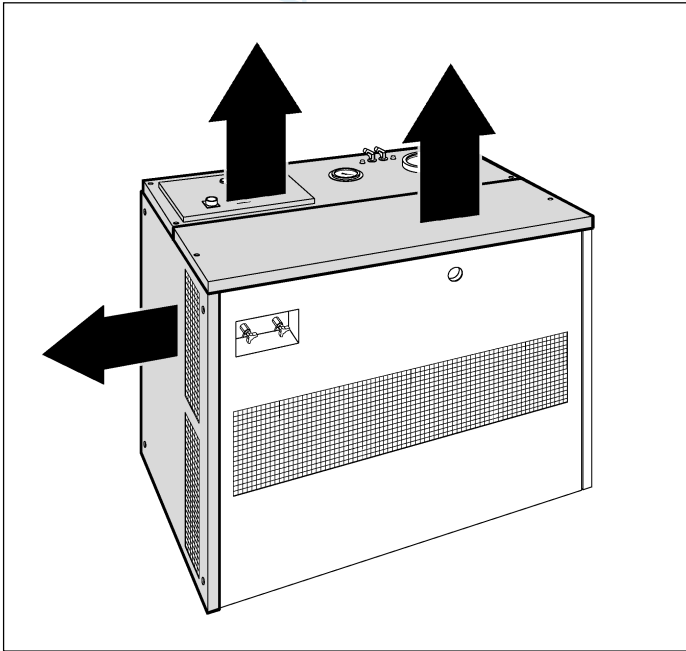

- 2 By exerting a pressure of at least 5 Kg., check that the belt does not yield by more than 5 mm. compared to its original position.

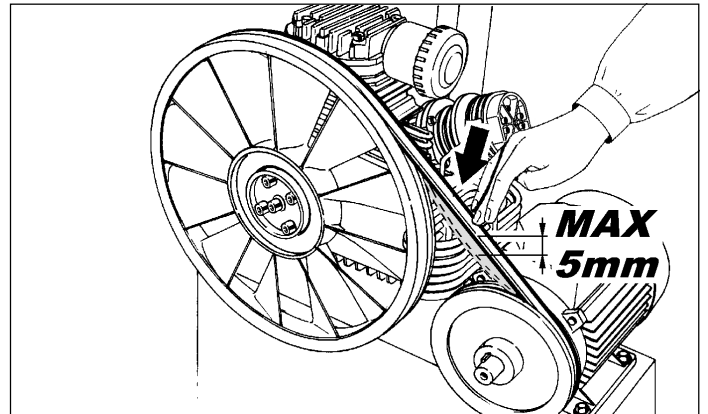

If this distance should exceed 5 mm., intervene by loosening the motor fastening screws, remove the drive belt and move the motor away from the compressor by a few millimetres by sliding it along the slots.

Tighten the motor fastening screws.

Refit the belt, placing it in the race provided in the motor pulley and in the innermost race of the fan, turning it by hand to enable the belt to go over the diameter of the fan and to fit into the race.

- 3 Carry out the measurement procedure again and if necessary, repeat the operations until a maximum distance of 5 mm. is reached.
- 4 Replace the covers securing the appropriate screws tightly (see point 1).

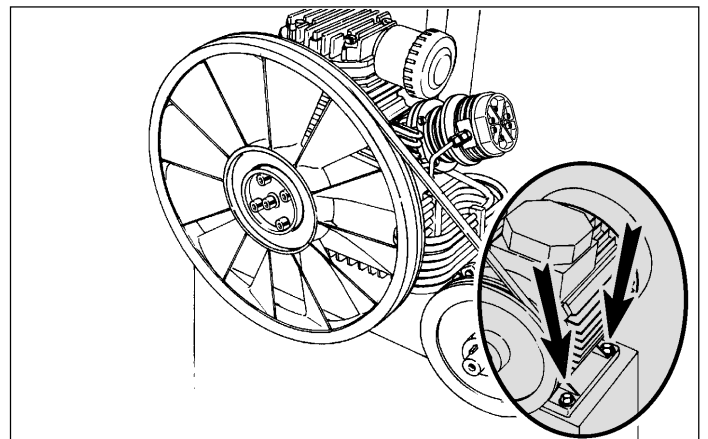

## AIR INTAKE FILTER

The intake filter must be checked to make sure it is in good order every 25 operating hours.

The filter is cleaned by blowing air inside the cartridge when it has been removed.

Replace the cartridge turning it by 60° compared to its initial position.

The filter must be replaced every 125 operating hours with the following procedure:

MCH 13-16/ET Compact

- 1 Remove the upper protective cover by unscrewing the securing screws.

MCH 13-16/ET Compact

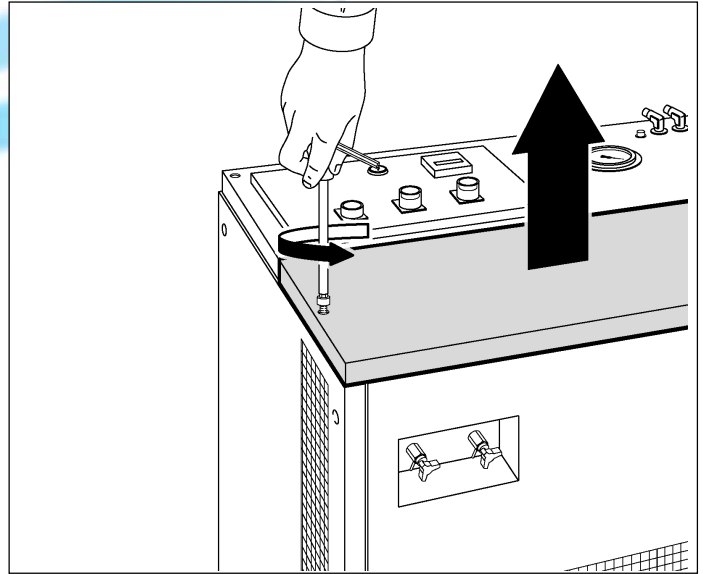

MCH 26-32/ET Compact

- 1 Remove the left-hand side protective cover (looking at the compressor from the **front**), by unscrewing the fixing screws.

MCH 26-32/ET Compact

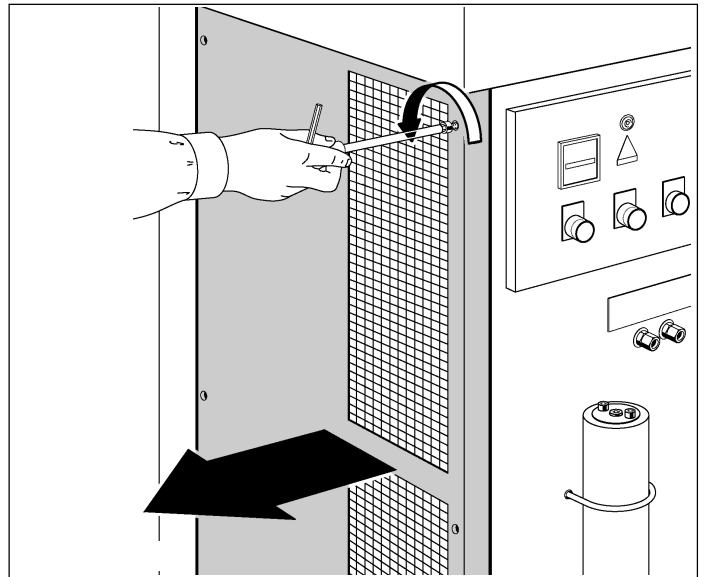

- 2 Press cap n° 1 lightly and turn it in an anti-clockwise direction.

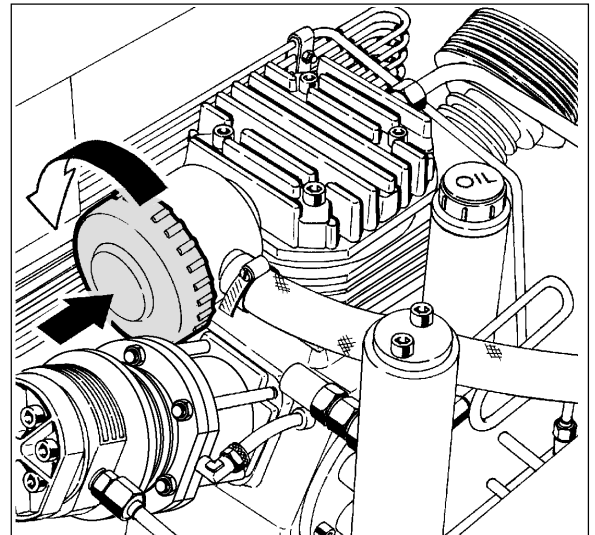

- 3** Remove the filter and replace it with a new one.  
To order a new spare filter, refer to chapter 14 "Spare parts".

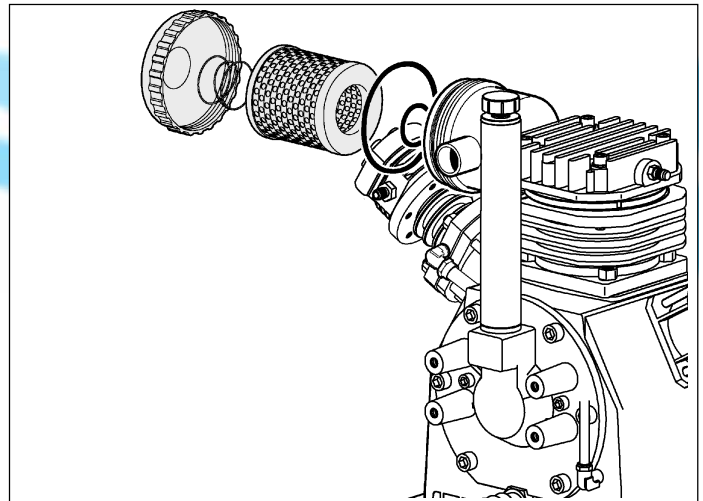

- 4** Refit the safety guard and tighten the screws (see point 1).

### ACTIVATED CARBON FILTER AND MOLECULAR SIEVE

The cartridges must be replaced before the air becomes foul-smelling.

The quality of the air depends to a large extent on the condition of the filtering cartridge. For this reason, it is important to comply with the intervals as specified.

The frequency of replacement has been calculated for use of the compressor with intake air at a temperature of 20 °C (68 °F), see table 4. If the temperatures differ, apply the coefficients given in the following table 3 to the duration of the filter:

**Table 3**

°C	°F	Multiplication coefficients
50	122	0.20
40	104	0.34
30	86	0.57
20	68	1
10	50	1.85
5	41	2.60
0	32	3.80

**Table 4**

MODEL	N° OF 10 LITRE CYLINDERS TO BE FILLED				VOLUME OF FILTERED AIR		DURATION OF THE FILTER	
	200 bar		300 bar		cu.m.		hours	
MCH 13/ET	322		214		644		50	
MCH 16/ET	322		214		644		40	
MCH 26/ET	322	322	214	214	644	644	50	50
MCH 32/ET	322	322	214	214	644	644	40	40

Check the sealing O-Rings and replace them if they are damaged.

Leave the cartridge in the filter when the compressor is not in use.

Maintain a pressure of 40-70 bar inside the filter to prevent outside damp from getting in.

To replace the activated carbon filter, proceed as follows:

- unscrew the external cap using a lever between the screws "A";

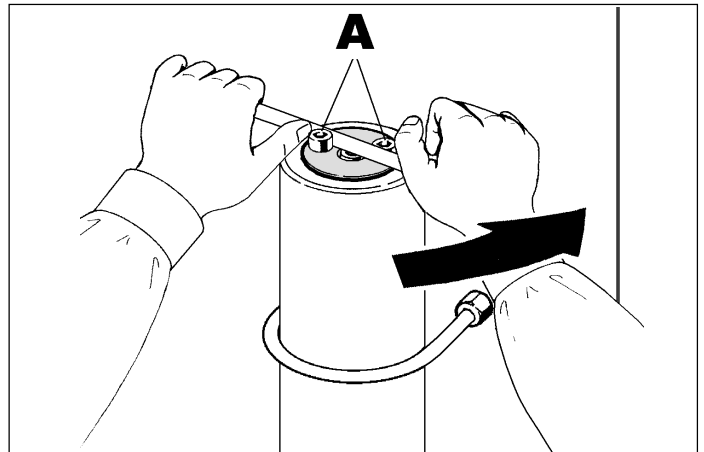

- remove the external cap and the internal cap;

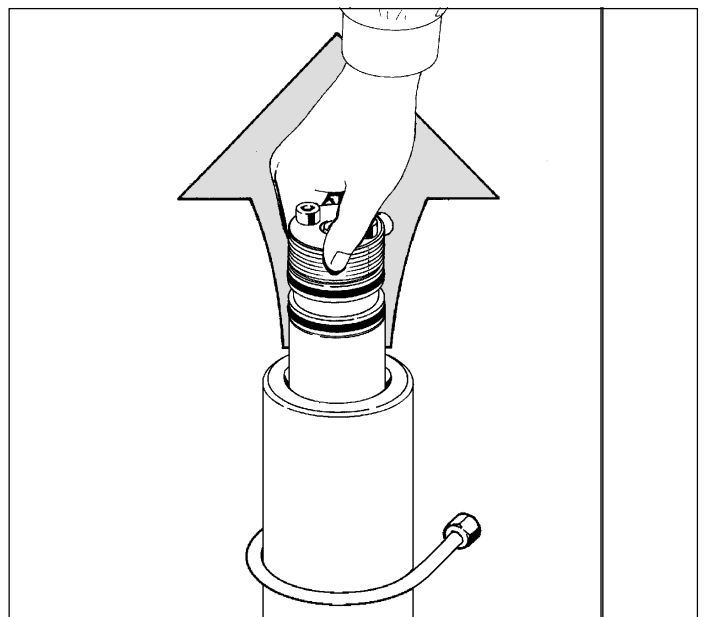

- unscrew the used cartridge from the internal cap and then screw in the new one;
- screw up the internal cap having lubricated or replaced the sealing O-Rings if they are worn and having lubricated the threads of the external cap using silicone grease.

**WARNING**

The used activated carbon filter cannot be disposed of together with urban waste. To dispose of it, follow the instructions given in chapter 10.2, "Disposal of waste products" with great care.

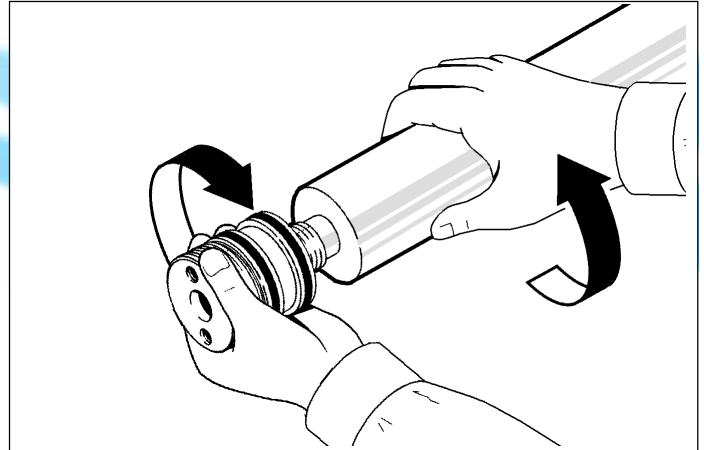
**FILLING HOSE**

The filling hose must be in good condition especially in the area of the connections.

The plastic sheath that covers the hose must not show any signs of abrasion otherwise if any humidity infiltrates, it could corrode the steel plait and reduce its resistance. The hose must be replaced periodically (annually) and/or when it shows signs of wear. Failure to comply with this regulation could cause serious danger to the operators. Make sure that the minimum radius of curvature of the hose is not less than 250 mm.

To connect the hose, follow the instructions given in chapter 6.2.2, "Connecting the filling hose".

**INLET AND DISCHARGE VALVES**

The 2<sup>nd</sup> stage inlet valve can be removed for maintenance purposes while those of the 1<sup>st</sup>, 2<sup>nd</sup> (only discharge) and 3<sup>rd</sup> stages must be entirely replaced. The seats must be cleaned carefully using petrol and soft brass or nylon brushes.

The torque wrench setting for the head bolts of the 3<sup>rd</sup> stage is initially 1 Kgm. Having moved the head closer, tighten the bolts to 2.2 Kgm, making sure that the piston is at the bottom dead centre during the operation.

Avoid using steel brushes or screwdrivers. The interval between maintenance operations is 400-600 working hours. If any parts are damaged or worn, they must be replaced. The discharge valves can be removed from the outside while the inlet valves can only be removed when the head of the cylinder has been taken off.

**NOTE:** the valve replacement procedure must be carried out at the work bench by specialized technicians who have specific equipment for the stripping operation.

## VALVE HEADS

- The head of the 1<sup>st</sup> stage (A) is of the lamellar type. It must be fitted so that the word "TOP" remains upwards and the flaps correspond with the openings in the cover of the head. Replace every 1000 hours.
- The head of the 2<sup>nd</sup> stage (B) is made of aluminium, the valves are screwed in; the inlet valve inside is removed using a special pin wrench while the discharge valve is on the outside and is removed with a non-adjustable wrench or a box wrench.
- The head of the 3<sup>rd</sup> stage (C) is made of aluminium, the inlet valve is screwed inside and can be removed using a special pin wrench while the discharge valve is on the outside and is kept in position by the threaded dowel which is screwed into the cover.

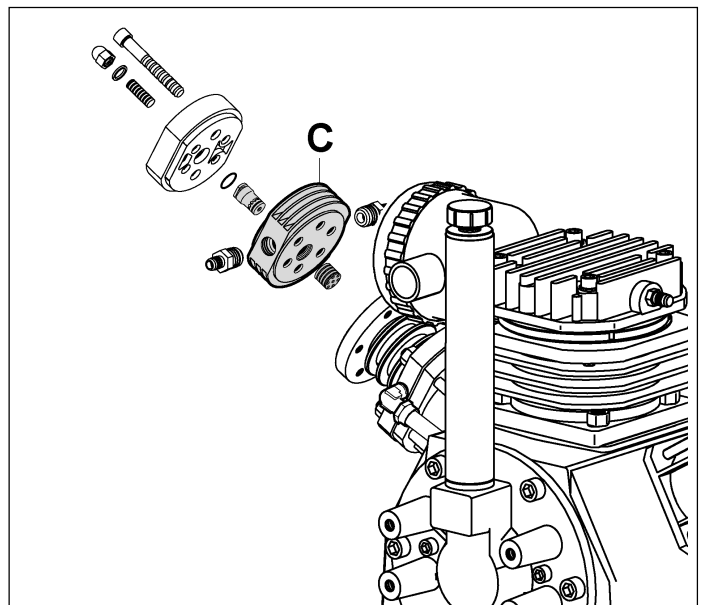
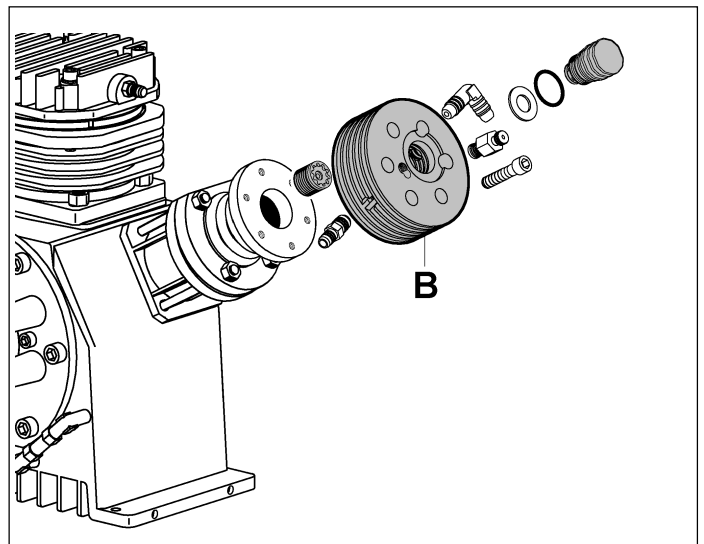
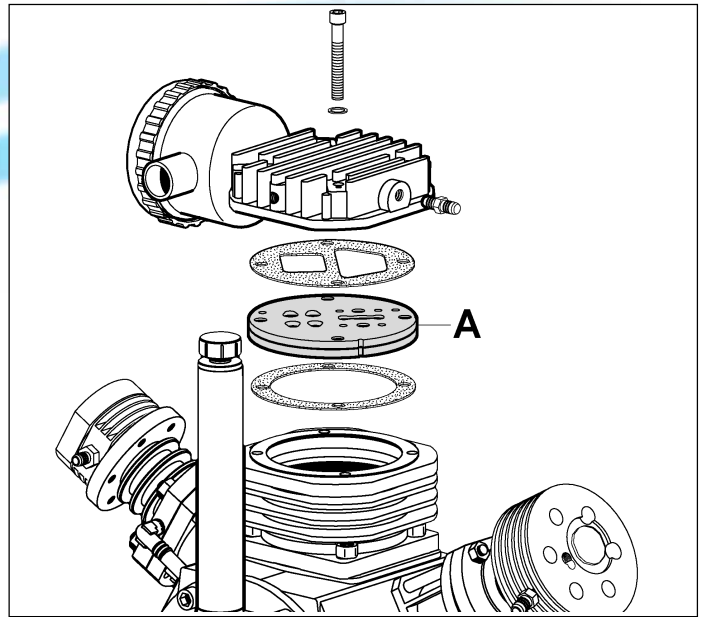

## CYLINDERS

After removing the cylinders, it is necessary to check, when they are replaced, that the piston at the maximum point and the upper edge of the cylinder are on the same level (Fig. 88).

Adjust any differences that there may be by making the base of the cylinder thicker using gaskets.

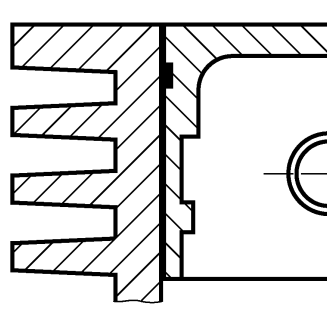

## 6.3 “MINI-SUPER SILENT” PROGRAMMED MAINTENANCE

### GENERAL NOTES

#### WARNING

All the routine and additional maintenance operations must be carried out with the machine at a standstill (the compressor at a standstill) and with the power supply disconnected.

The residue pressure in the machine (pump circuit) must be eliminated.

Any operation carried out on the machine must only be undertaken having read and carefully applied the regulations listed in Chapter 4 “Precautions for use and maintenance”. To keep the machine in good working condition, it must be cleaned very thoroughly.

Having been designed and built according to the most advanced technological criteria, this type of filling station requires very limited preventive and routine maintenance operations.

However, it is essential to follow the indications given in this chapter very carefully and to follow the intervals between operations as suggested.

During the guarantee period no responsibility is taken for any damage or operating faults due to a failure to comply with the regulations in force.

The following paragraph enables all the routine and additional maintenance operations carried out on the machine to be recorded.

This paragraph should be filled in carefully and any operations carried out to solve problems should also be reported.

### PREVENTIVE MAINTENANCE (TABLE 1)

**Table 1**

		INTERVALS												
		X	1 day	15 min	30 min	25 h	50 h	125 h	250 h	500 h	1000 h	5000 h		
1	Replace the activated carbon cartridge, see par. 11.7													
2	Check the compressor oil level					○								
3	First compressor oil change					●								
4	Change compressor oil								●					
5	Intake filter cartridge					○		●						
6	Operation of the end safety valve					○								
7	Operation and tightness of the filling valve					○								
8	Alignment of the compressor needle with the ○ when the compressor is depressurized					○								
9	Tightening of the cooling pipes							○						
10	Tightening of the connecting pipes							○						
11	Belt tension and wear								○		●			
12	Hose replacement										●			
13	2 <sup>nd</sup> and 3 <sup>rd</sup> stage intake and discharge valves									●				
14	Internal cleaning of end separator								○					
15	Tightening of all the screws								○					
16	General cleaning								○					
17	Replacement of the external casing of the strainer filter												●	
18	Replacement of 1 <sup>st</sup> stage head										●			

●= replacement

○= inspection, cleaning

**CHANGING THE LUBRICANT OIL  
(TABLE 2)**

The quantity of oil for the lubrication of the pump unit must be checked every 25 hours.

To carry out this operation, see chapter 8 "Start up".

The oil must be changed every 250 operating hours or yearly.

When changing the oil, do not use a mixture of different oils.

The oil must have the following characteristics:

**Table 2**

		MCH 13	MCH 16
<b>Sump capacity</b>	cu.cm. litres/gallons	1500 1.5/0.476	1500 1.5/0.476
<b>Recommended oils</b>		AEROTECNICA COLTRI SPECIAL MINERAL OIL AEROTECNICA COLTRI SPECIAL SYNTHETIC OIL MOBIL SPECIAL 20 W 50 MOBIL RARUS 827-829 ANDEROL 755 SYNTHETIC	
<b>Viscosity of the oil</b>	summer  winter	above +10 °C (50 °F) SAE 20 W/40  from +10 °C to -15 °C (50° to 5 °F) SAE 10 W below -15 °C (5 °F) SAE 5 W	
<b>Maximum tilt of the compressor with the oil level at maximum</b>	degrees	~ 5	

To change the oil, proceed as follows:

- 1 Use a basin with a minimum capacity of 2.5 lt. capacity under the oil discharge tap
  
- 2 Unscrew the hexagonal closing cap located in front of the oil discharge.

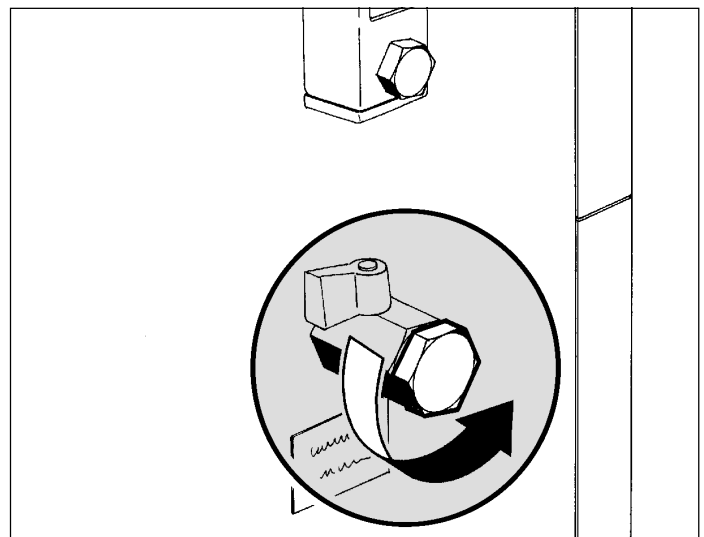

- 3 Close the discharge tap and replace the hexagonal closing cap.
- 4 Carry out the filling operations as described in chapter 8 "Start up".

## WARNING

To dispose of waste oils follow the instructions given in chapter 10.2 "Disposal of waste products" with great care.

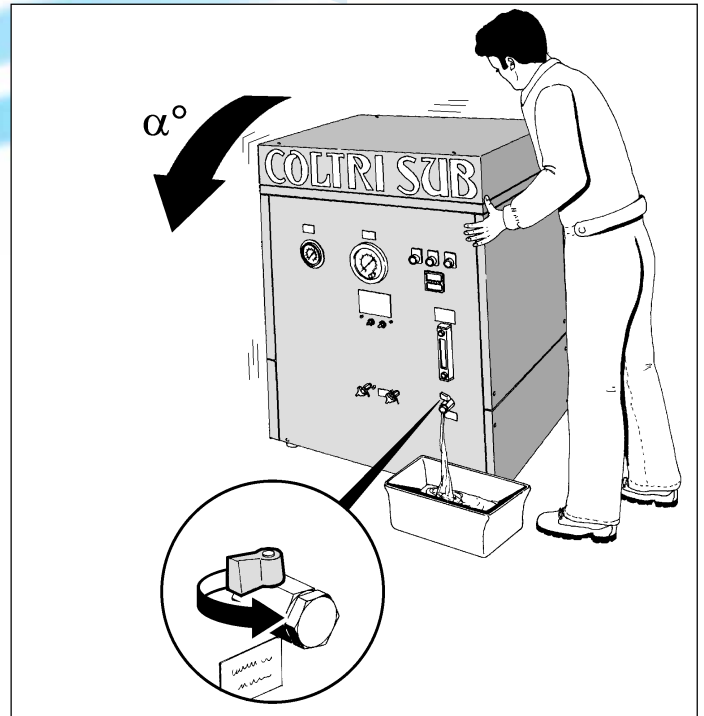

## CHECKING THE DRIVE BELT

The drive belt is checked by measuring the yield of the same.

This operation must be carried out every 250 machine operating hours as described below:

- 1 Remove the safety guard by unscrewing the fastening screws (Mini Silent) or by opening the locks of the side panels and removing them (Super Silent).

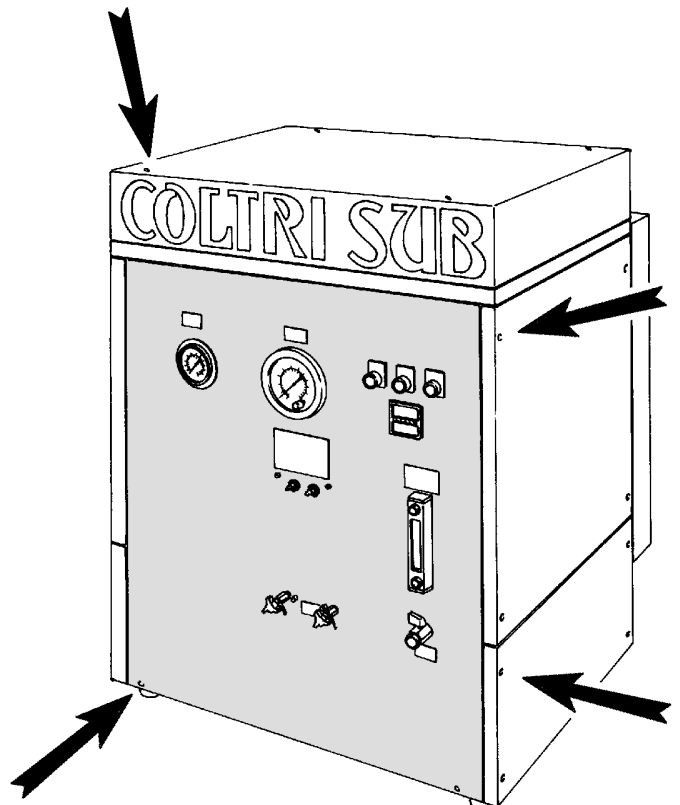

- 2 By exerting a pressure of at least 5 Kg., check that the belt does not yield by more than 5 mm. compared to its original position.

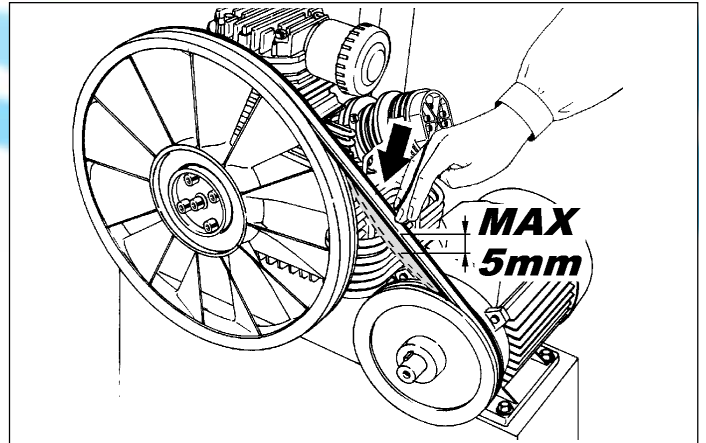

If this distance should exceed 5 mm., intervene by loosening the motor fastening screws, remove the drive belt and move the motor away from the compressor by a few millimetres by sliding it along the slots.

Tighten the motor fastening screws.

Refit the belt, placing it in the race provided in the motor pulley and in the innermost race of the fan, turning it by hand to enable the belt to go over the diameter of the fan and to fit into the race.

- 3 Carry out the measurement procedure again and if necessary, repeat the operations until a maximum distance of 5 mm. is reached.
- 4 Refit the safety guard by securing the screws or by closing the locks (see point 1).

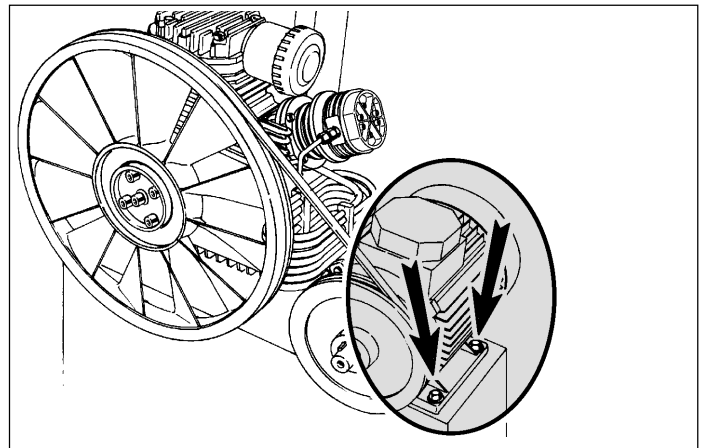

## AIR INTAKE FILTER

The intake filter must be checked to make sure it is in good order every 25 operating hours.

The filter is cleaned by blowing air inside the cartridge when it has been removed.

Replace the cartridge turning it by 60° compared to its initial position.

- unlocking the side panels and removing them (Super Silent).

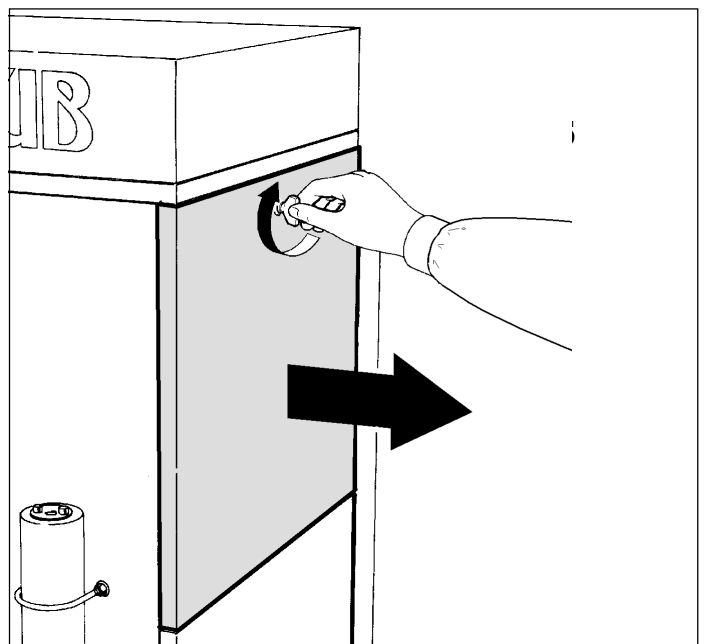

2 Press cap n° 1 lightly and turn it in an anti-clockwise direction.

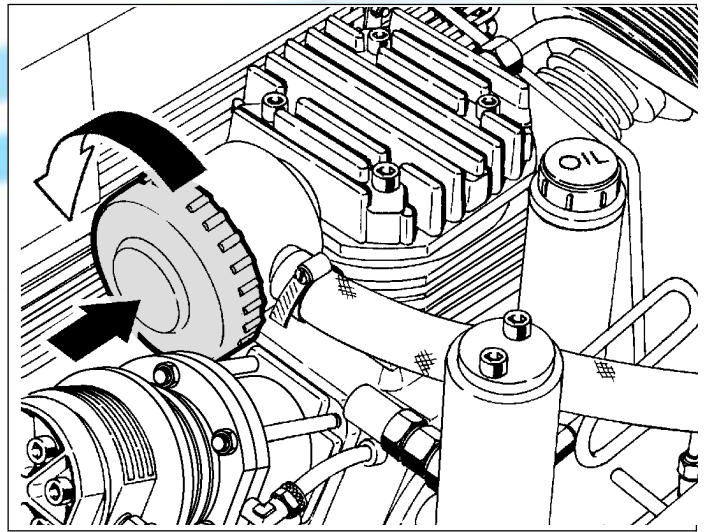

3 Remove the filter and replace it with a new one.  
To order a new spare filter, refer to chapter 14 "Spare parts".

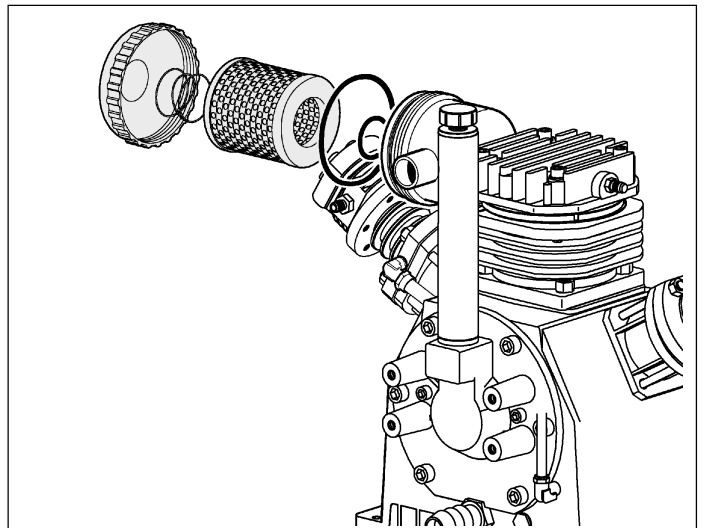

4 Refit the safety guard and tighten the screws (see point 1).

Per la sostituzione del filtro a carboni attivi operare come segue:

- svitare il tappo esterno agendo con una leva

**ACTIVATED CARBON FILTER AND MOLECULAR SIEVE**

The cartridge must be replaced before the air becomes foul smelling.

The quality of the air depends to a large extent on the condition of the filtering cartridge. For this reason, it is important to comply with the intervals as specified.

The frequency of replacement has been calculated for use of the compressor with intake air at a temperature of 20 °C (68 °F), see table 4. If the temperatures differ, apply the coefficients given in the following table 3 to the duration of the filter:

°C	°F	Multiplication coefficients
50	122	0.20
40	104	0.34
30	86	0.57
20	68	1
10	50	1.85
5	41	2.60
0	32	3.80

**Table 3**

**Table 4**

MODEL	N° OF 10 LITRE CYLINDERS TO BE FILLED		VOLUME OF FILTERED AIR cu.m.	DURATION OF THE FILTER hours
	200 bar	300 bar		
MCH13 ETS	322	214	644	50
MCH16 ETS	322	214	644	40

Check the sealing O-Rings and replace them if they are damaged.

Leave the cartridge in the filter when the compressor is not in use.

Maintain a pressure of 40-70 bar inside the filter to prevent outside damp from getting in.

To replace the activated carbon filter, proceed as follows:

- unscrew the external cap using a lever between the screws "A";

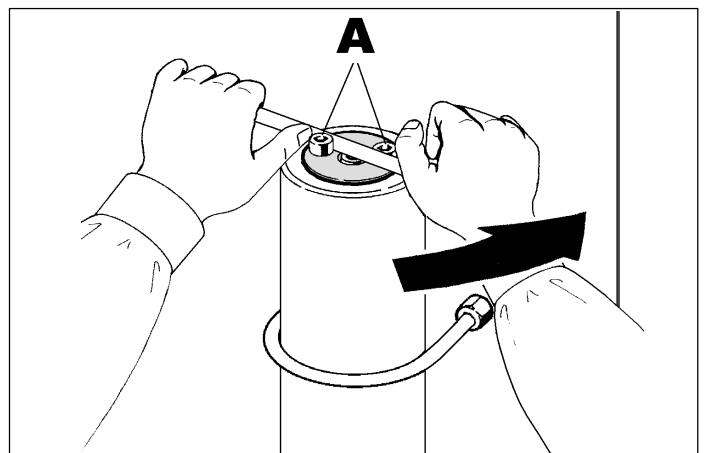

- remove the external cap and the internal cap;

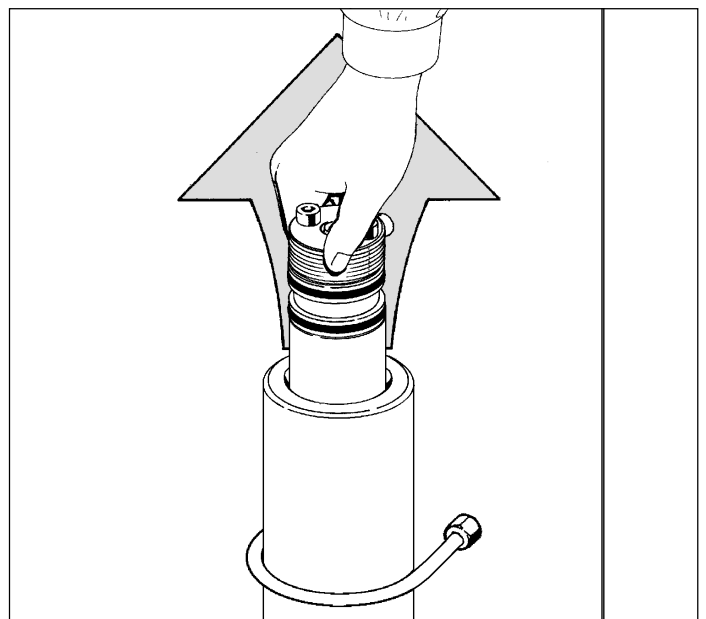

- unscrew the used cartridge from the internal cap and then screw in the new one;
- screw up the internal cap having lubricated or replaced the sealing O-Rings if they are worn and having lubricated the threads of the external cap using silicone grease.

## WARNING

The used activated carbon filter cannot be disposed of together with urban waste. To dispose of it, follow the instructions given in chapter 10.2, "Disposal of waste products" with great care.

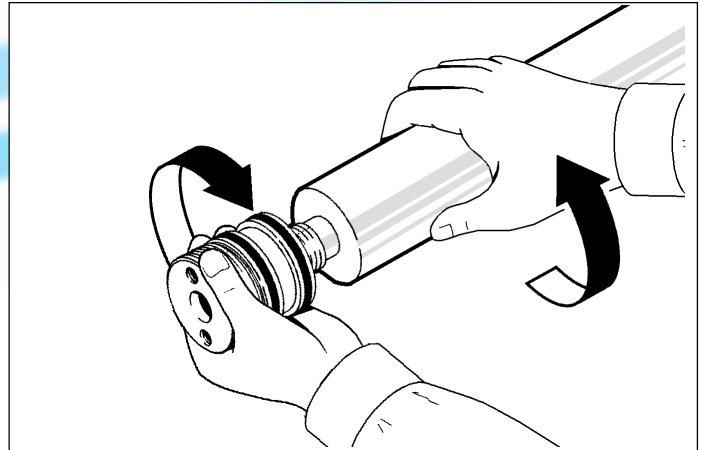

## FILLING HOSE

The filling hose must be in good condition especially in the area of the connections.

The plastic sheath that covers the hose must not show any signs of abrasion otherwise if any humidity infiltrates, it could corrode the steel plait and reduce its resistance. The hose must be replaced periodically (annually) and/or when it shows signs of wear. Failure to comply with this regulation could cause serious danger to the operators. Make sure that the minimum radius of curvature of the hose is not less than 250 mm.

To connect the hose, follow the instructions given in chapter 6.2.2, "Connecting the filling hose".

## INLET AND DISCHARGE VALVES

The 2<sup>nd</sup> stage inlet valve can be removed for maintenance purposes while those of the 1<sup>st</sup>, 2<sup>nd</sup> (only discharge) and 3<sup>rd</sup> stages must be entirely replaced. The seats must be cleaned carefully using petrol and soft brass or nylon brushes.

The torque wrench setting for the head bolts of the 3<sup>rd</sup> stage is initially 1 Kgm. Having moved the head closer, tighten the bolts to 2.2 Kgm, making sure that the piston is at the bottom dead centre during the operation.

Avoid using steel brushes or screwdrivers. The interval between maintenance operations is 400-600 working hours. If any parts are damaged or worn, they must be replaced. The discharge valves can be removed from the outside while the inlet valves can only be removed when the head of the cylinder has been taken off.

**NOTE:** the valve replacement procedure must be carried out at the work bench by specialized technicians who have specific equipment for the stripping operation. In any case, it is preferable to contact **AEROTECNICA COLTRI S.r.l.** who will supply the necessary technical assistance.

**VALVE HEADS**

- The head of the 1<sup>st</sup> stage (A) is of the lamellar type. It must be fitted so that the word "TOP" remains upwards and the flaps correspond with the openings in the cover of the head. Replace every 1000 hours.

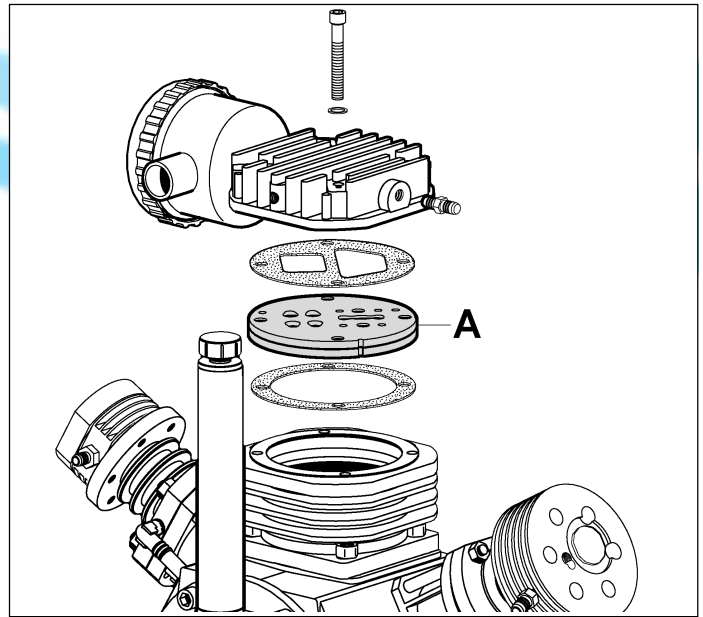

- The head of the 2<sup>nd</sup> stage (B) is made of aluminium, the valves are screwed in; the inlet valve inside is removed using a special pin wrench while the discharge valve is on the outside and is removed with a non-adjustable wrench or a box wrench.

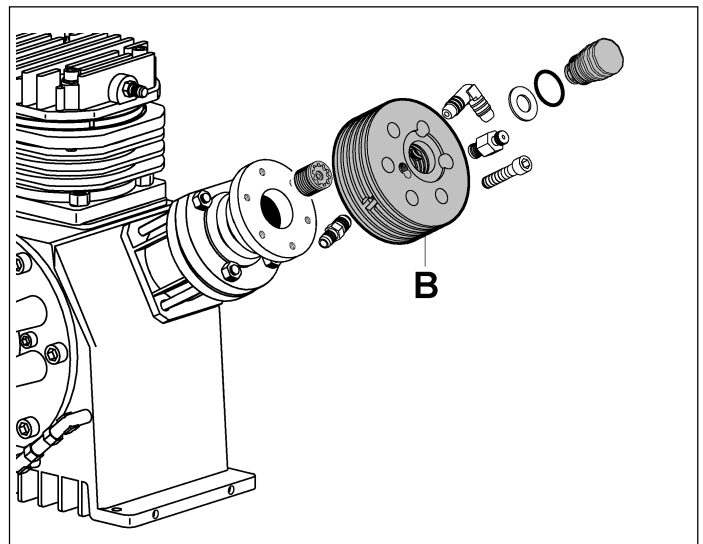

- The head of the 3<sup>rd</sup> stage (C) is made of aluminium, the inlet valve is screwed inside and is removed using a special pin wrench while the discharge valve is on the outside and is kept in position by the threaded dowel which is screwed into the cover.

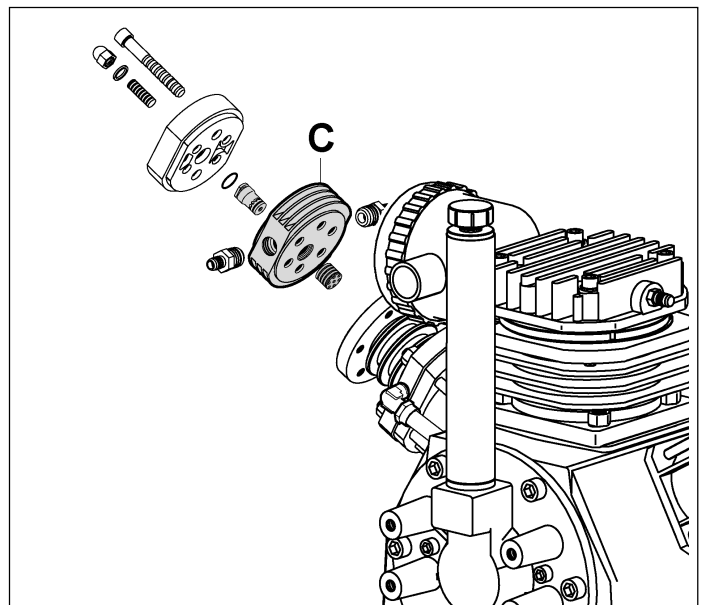

## CYLINDERS

After removing the cylinders, it is necessary to check, when they are replaced, that the piston at the maximum point and the upper edge of the cylinder are on the same level.

Adjust any differences that there may be by making the base of the cylinder thicker using gaskets.

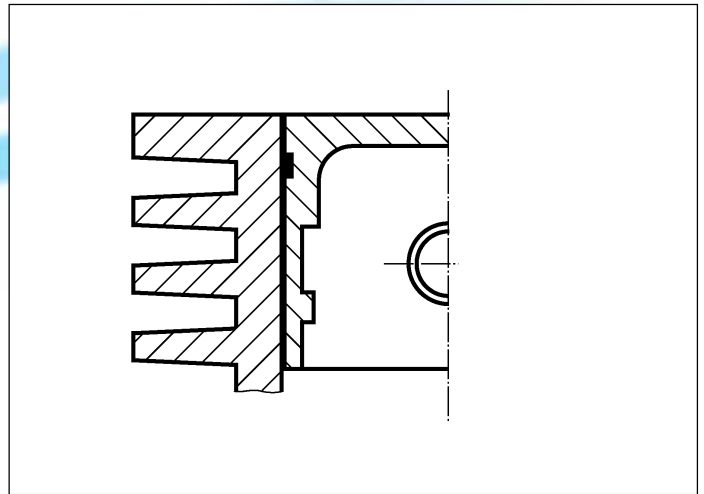

## 6.4 "OPEN" PROGRAMMED MAINTENANCE

### WARNING

All the routine and additional maintenance operations must be carried out with the machine at a standstill (the compressor at a standstill) and with the power supply disconnected.

The residue pressure in the machine (pump circuit) must be eliminated. Any operation carried out on the machine must only be undertaken having read and carefully applied the regulations listed in Chapter 4 "Precautions for use and maintenance".

### GENERAL NOTES

To keep the machine in good working condition, it must be cleaned very thoroughly.

Having been designed and built according to the most advanced technological criteria, this type of filling station requires very limited preventive and routine maintenance operations.

However, it is essential to follow the indications given in this chapter very carefully and to follow the intervals between

operations as suggested. During the guarantee period no responsibility is taken for any damage or operating faults due to a failure to comply with the regulations in force.

The following paragraph enables all the routine and additional maintenance operations carried out on the machine to be recorded. This paragraph should be filled in carefully and any operations carried out to solve problems should also be reported. volta suggerita.

### PREVENTIVE MAINTENANCE (TABLE 1)

Table 1

		INTERVALS									
X		1 day	15 min	30 min	25 h	50 h	125 h	250 h	500 h	1000 h	5000 h
1	Replace the activated carbon cartridge, see par. 11.7					○					
2	Check the compressor oil level					○					
3	First compressor oil change				●						
4	Change compressor oil							●			
5	Intake filter cartridge				○		●				
6	Operation of the end safety valve				○						
7	Operation and tightness of the filling valve				○						
8	Alignment of the compressor needle with the ○ when the compressor is depressurized				○						
9	Tightening of the cooling pipes						○				
10	Tightening of the connecting pipes						○				
11	Belt tension and wear							○		●	
12	Hose replacement									●	
13	2 <sup>nd</sup> and 3 <sup>rd</sup> stage intake and discharge valves								●		
14	Internal cleaning of end separator							○			
15	Tightening of all the screws							○			
16	General cleaning							○			
17	Replacement of the external casing of the strainer filter										●
18	Replacement of 1 <sup>st</sup> stage head									●	

● = replacement

○ = inspection, cleaning



## CHECKING THE DRIVE BELT

The drive belt is checked by measuring the yield of the same.

This operation must be carried out every 250 machine operating hours as described below:

- 1 Remove the front safety guard as shown in figure 53 by unscrewing the fastening screws.
- 2 By exerting a pressure of at least 5 Kg., check that the belt does not yield by more than 5 mm. compared to its original position.

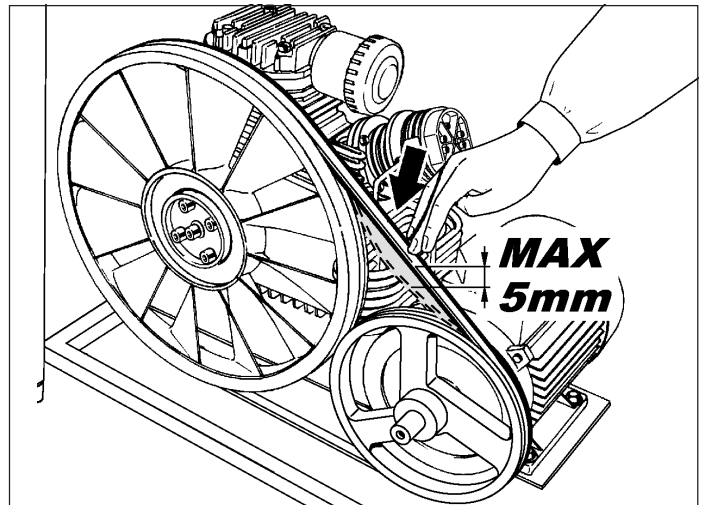
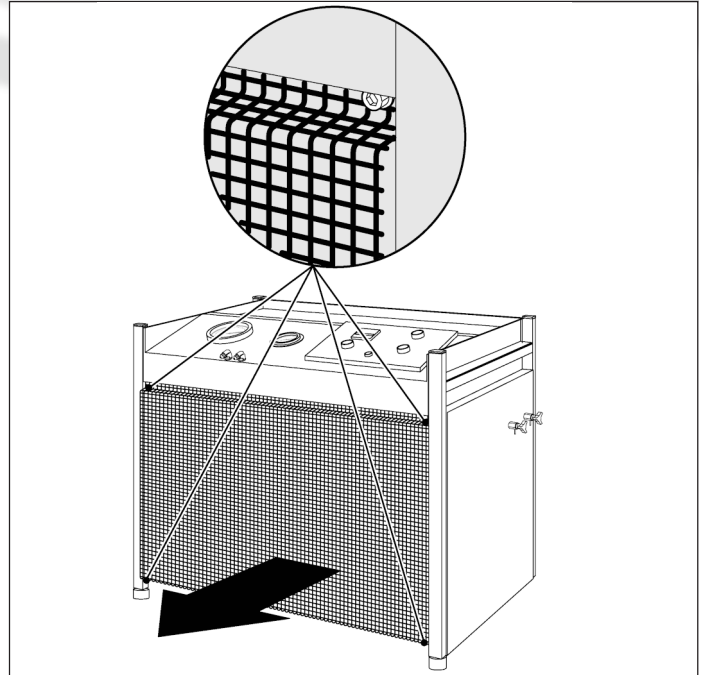

If this distance should exceed 5 mm., intervene by loosening the motor fastening screws, remove the drive belt and move the motor away from the compressor by a few millimetres by sliding it along the slots.

Tighten the motor fastening screws.

Refit the belt, placing it in the race provided in the motor pulley and in the innermost race of the fan, turning it by hand to enable the belt to go over the diameter of the fan and to fit into the race.

- 3 Carry out the measurement procedure again and if necessary, repeat the operations until a maximum distance of 5 mm. is reached.
- 4 Replace the covers securing the appropriate screws tightly (see point 1).

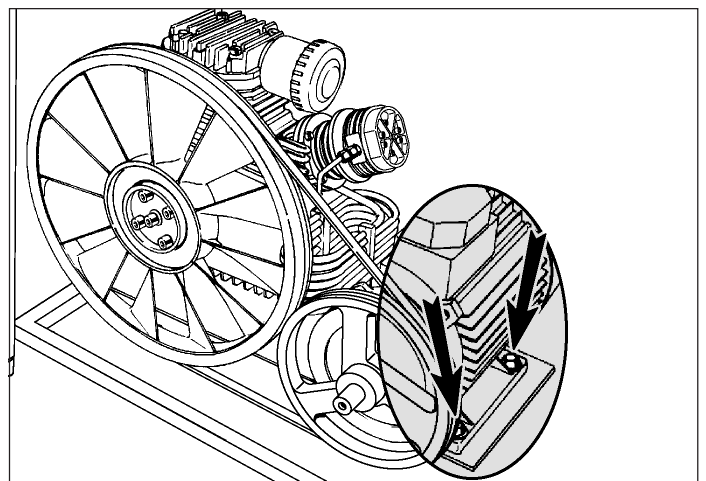

## AIR INTAKE FILTER

The intake filter must be checked to make sure it is in good order every 25 operating hours.

The filter is cleaned by blowing air inside the cartridge when it has been removed.

Replace the cartridge turning it by 60° compared to its initial position.

- 1 Press cap n° 1 lightly and turn it in an anti-clockwise direction.

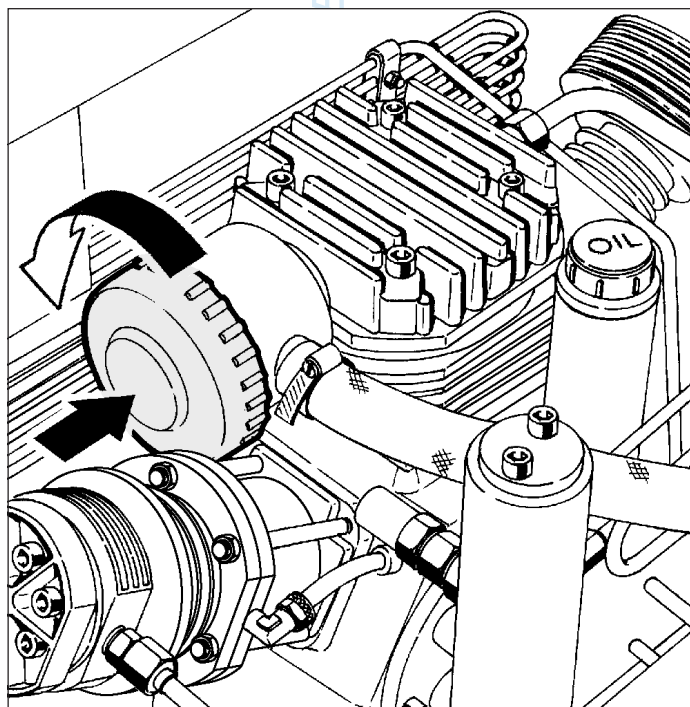

- 2 Remove the filter and replace it with a new one (Fig. 57).  
To order a new spare filter, refer to chapter 14 "Spare parts".

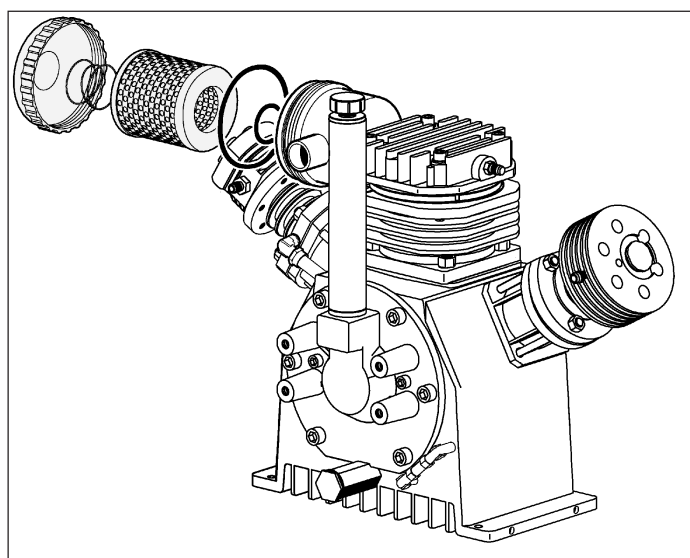

## ACTIVATED CARBON FILTER AND MOLECULAR SIEVE

The cartridges must be replaced before the air becomes foul-smelling.

The quality of the air depends to a large extent on the condition of the filtering cartridge. For this reason, it is important to comply with the intervals as specified.

The frequency of replacement has been calculated for use of the compressor with intake air at a temperature of 20 °C (68 °F), see table 4. If the temperatures differ, apply the coefficients given in the following table 3 to the duration of the filter:

Table 3

°C	°F	Multiplication coefficients
50	122	0.20
40	104	0.34
30	86	0.57
20	68	1
10	50	1.85
5	41	2.60
0	32	3.80

Table 4

MODEL	N° OF 10 LITRE CYLINDERS TO BE FILLED		VOLUME OF FILTERED AIR m <sup>3</sup>	DURATION OF THE FILTER hours
	200 bar	300 bar		
MCH 13/ET	322	214	644	50
MCH 16/ET	322	214	644	50

Check the sealing O-Rings and replace them if they are damaged. Leave the cartridge in the filter when the compressor is not in use.

Maintain a pressure of 40-70 bar inside the filter to prevent outside damp from getting in.

To replace the activated carbon filter, proceed as follows:

- unscrew the external cap using a lever between the screws "A";

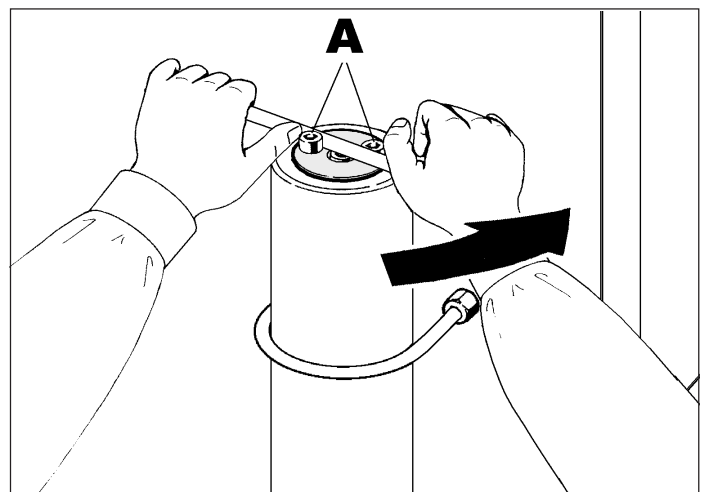

- unscrew the external cap using a lever between the screws "A";

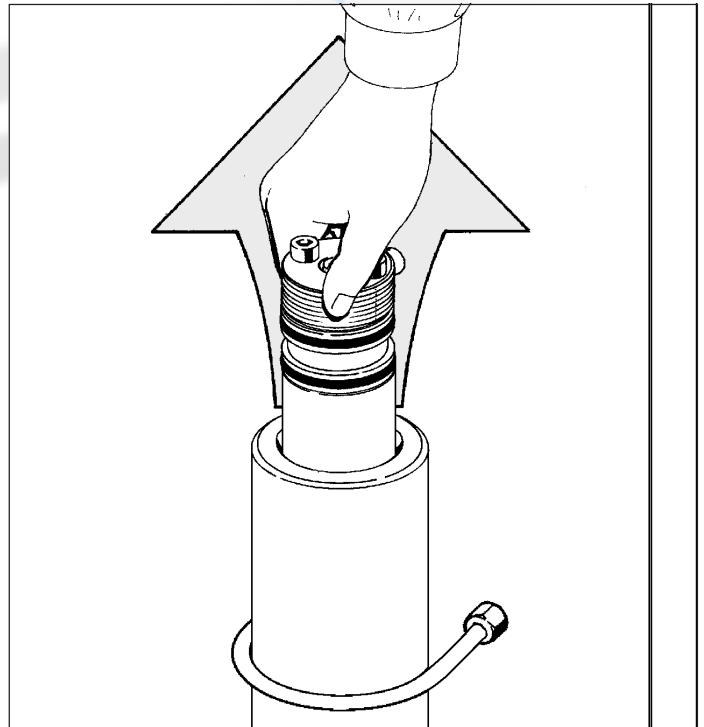

- unscrew the used cartridge from the internal cap and then screw in the new one;

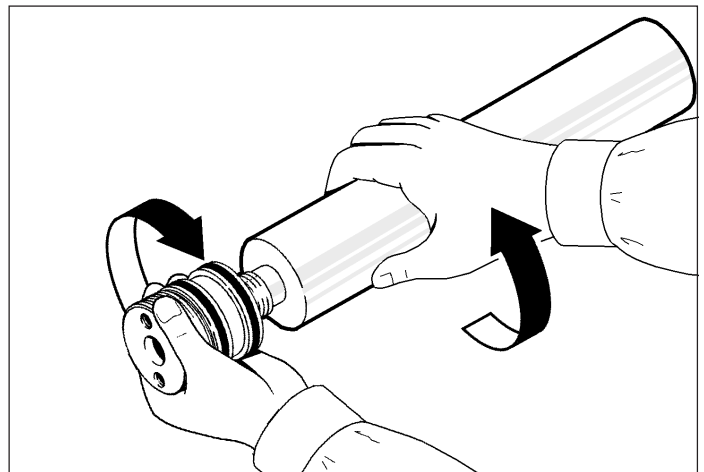

- screw up the internal cap having lubricated or replaced the sealing O-Rings if they are worn and having lubricated the threads of the external cap using silicone grease.

## WARNING

The used activated carbon filter cannot be disposed of together with urban waste. To dispose of it, follow the instructions given in chapter 10.2, "Disposal of waste products" with great care.



## FILLING HOSE

The filling hose must be in good condition especially in the area of the connections. The plastic sheath that covers the hose must not show any signs of abrasion otherwise if any humidity infiltrates, it could corrode the steel plait and reduce its resistance. The hose must be replaced periodically (annually)

and/or when it shows signs of wear. Failure to comply with this regulation could cause serious danger to the operators. Make sure that the minimum radius of curvature of the hose is not less than 250 mm. To connect the hose, follow the instructions given in chapter 6.2.2, "Connecting the filling hose".

## INLET AND DISCHARGE VALVES

The 2<sup>nd</sup> stage inlet valve can be removed for maintenance purposes while those of the 1<sup>st</sup>, 2<sup>nd</sup> (only discharge) and 3<sup>rd</sup> stages must be entirely replaced. The seats must be cleaned carefully using petrol and soft brass or nylon brushes.

The torque wrench setting for the head bolts of the 3<sup>rd</sup> stage is initially 1 Kgm. Having moved the head closer, tighten the bolts to 2.2 Kgm, making sure that the piston is at the bottom dead centre during the operation.

Avoid using steel brushes or screwdrivers. The interval between maintenance operations is 400-600 working hours. If any parts are damaged or worn, they must be replaced. The discharge valves can be removed from the outside while the inlet valves can only be removed when the head of the cylinder has been taken off.

**NOTE:** the valve replacement procedure must be carried out at the work bench by specialized technicians who have specific equipment for the stripping operation.

In any case, it is preferable to contact **AEROTECNICA COLTRI S.r.l.** who will supply the necessary technical assistance.

## VALVE HEADS

- The head of the 1<sup>st</sup> stage (A) is of the lamellar type (Fig. 61). It must be fitted so that the word "TOP" remains upwards and the flaps correspond with the openings in the cover of the head. Replace every 1000 hours.

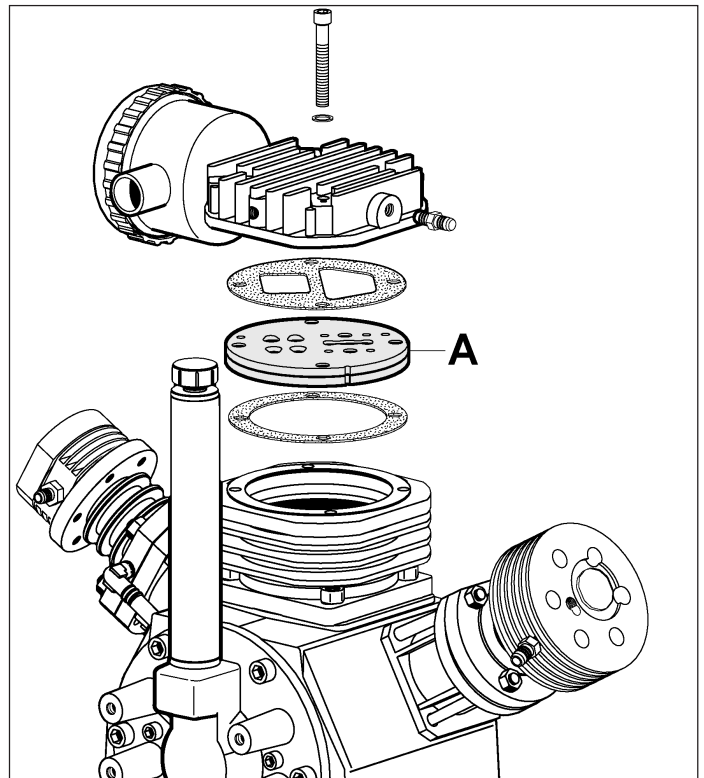

- The head of the 2<sup>nd</sup> stage (B) is made of aluminium, the valves are screwed in; the inlet valve inside is removed using a special pin wrench while the discharge valve is on the outside and is removed with a non-adjustable wrench or a box wrench.

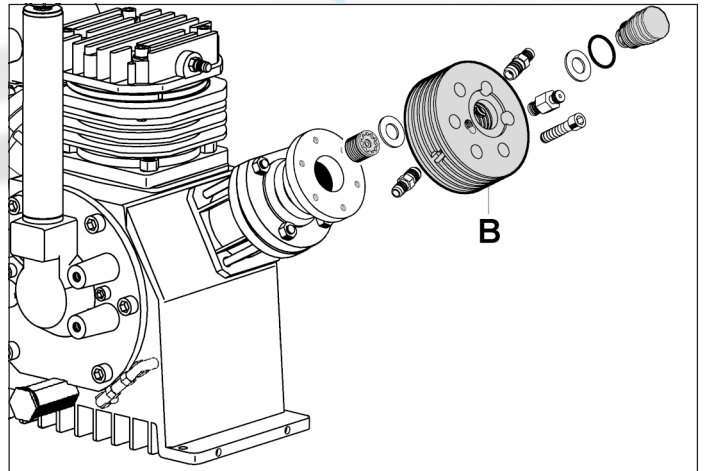

- The head of the 3<sup>rd</sup> stage (C) is made of aluminium, the inlet valve is screwed inside and is removed using a special pin wrench while the discharge valve is on the outside and is kept in position by the threaded dowel which is screwed into the cover.

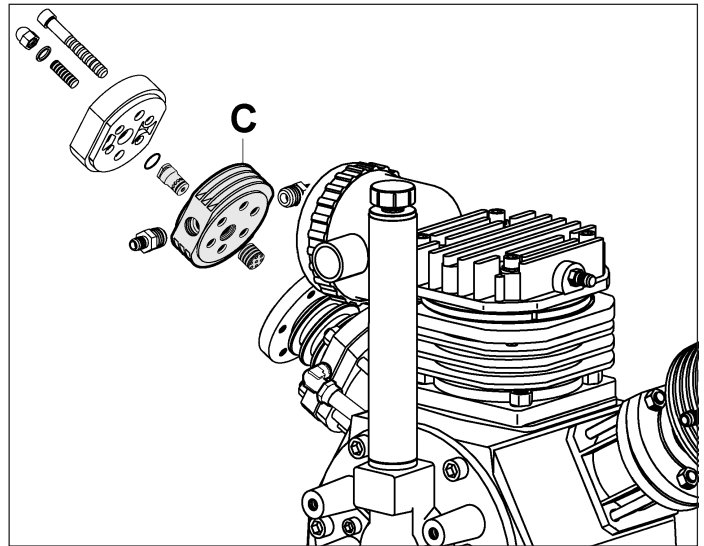

## CYLINDERS

After removing the cylinders, it is necessary to check, when they are replaced, that the piston at the maximum point and the upper edge of the cylinder are on the same level (Fig. 64).

Adjust any differences that there may be by making the base of the cylinder thicker using gaskets.

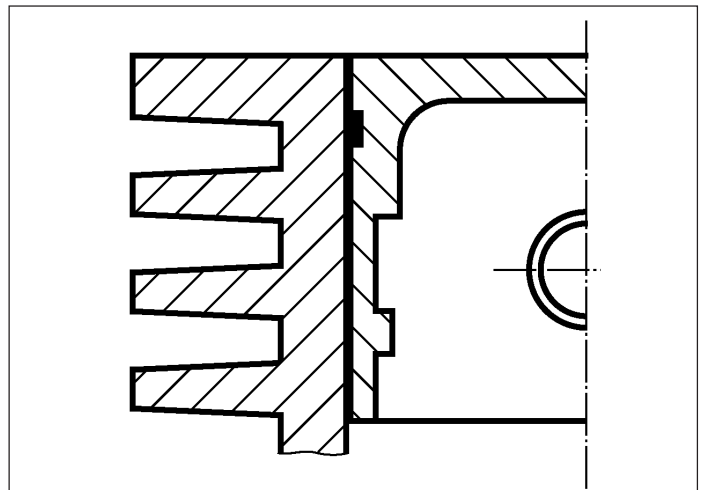

## 6.5 “STANDARD” PROGRAMMED MAINTENANCE

### GENERAL NOTES

To keep the machine in good working condition, it must be cleaned very thoroughly.

Having been designed and built according to the most advanced technological criteria, this type of filling station requires very limited preventive and routine maintenance operations.

However, it is essential to follow the indications given in this chapter very carefully and to follow the intervals between

operations as suggested. During the guarantee period no responsibility is taken for any damage or operating faults due to a failure to comply with the regulations in force.

The following paragraph enables all the routine and additional maintenance operations carried out on the machine to be recorded. This paragraph should be filled in carefully and any operations carried out to solve problems should also be reported.

### PREVENTIVE MAINTENANCE (TABLE 1)

Table 1

		INTERVALS										
		X	1 day	15 min	30 min	25 h	50 h	125 h	250 h	500 h	1000 h	5000 h
1	Replace the activated carbon cartridge, see par. 11.7						○					
2	Check the compressor oil level						○					
3	First compressor oil change					●						
4	Change compressor oil								●			
5	Intake filter cartridge					○		●				
6	Operation of the end safety valve					○						
7	Operation and tightness of the filling valve					○						
8	Alignment of the compressor needle with the ○ when the compressor is depressurized					○						
9	Tightening of the cooling pipes							○				
10	Tightening of the connecting pipes							○				
11	Belt tension and wear								○		●	
12	Hose replacement										●	
13	2 <sup>nd</sup> and 3 <sup>rd</sup> stage intake and discharge valves									●		
14	Internal cleaning of end separator								○			
15	Tightening of all the screws								○			
16	General cleaning								○			
17	Replacement of the external casing of the strainer filter											●
18	Replacement of 1 <sup>st</sup> stage head										●	

● = replacement

○ = inspection, cleaning

**CHANGING THE LUBRICANT OIL**

**(TABLE 2)**

The quantity of oil for the lubrication of the pump unit must be checked every 25 hours.

To carry out this operation, see chapter 8 "Start and stop".

The oil must be changed every 250 operating hours or yearly.

When changing the oil, do not use a mixture of different oils.

The oil must have the following characteristics:

**Table 2**

<b>Sump capacity</b>	cu.cm. litres/gallons	1500 1.5/0.476
<b>Recommended oils</b>		AEROTECNICA COLTRI SPECIAL MINERAL OIL AEROTECNICA COLTRI SPECIAL SYNTHETIC OIL MOBIL SPECIAL 20 W 50 MOBIL RARUS 827-829 ANDEROL 755 SYNTHETIC
<b>Viscosity of the oil</b>	summer winter	above +10 °C (50 °F) SAE 20 W/40 from +10 °C to -15 °C (50° to 5 °F) SAE 10 W below -15 °C (5 °F) SAE 5 W
<b>Maximum tilt of the compressor with the oil level at maximum</b>	degrees	~ 5

To change the oil, proceed as follows:

- 1 Use a basin with a minimum capacity of 2.5 lt. capacity under the oil discharge tap.

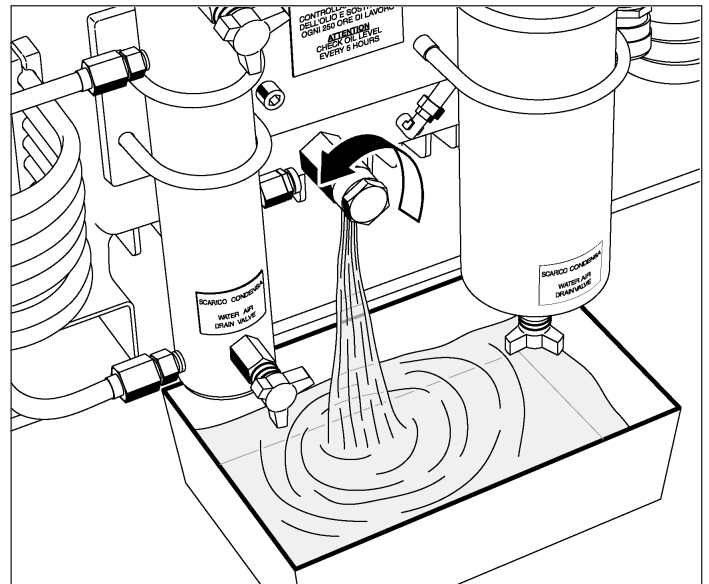

- 2 Unscrew the hexagonal closing cap located in front of the oil discharge and discharge all the oil in the pump.
- 3 Replace the hexagonal closing cap.
- 4 Carry out the filling operations as described in chapter 8 "Start and stop".

**WARNING**

To dispose of waste oils follow the instructions given in chapter 10.2 "Disposal of waste products" with great care.

## CHECKING THE DRIVE BELT

The drive belt is checked by measuring the yield of the same.

This operation must be carried out every 250 machine operating hours as described below :

- 1 Remove the protective cover as shown in figures 117, 118 and 119, by unscrewing the fixing screws.

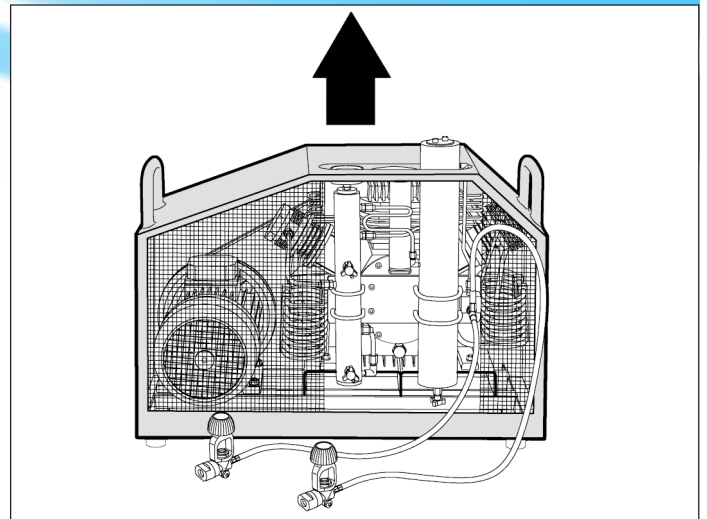

**MCH 13-16/ETC STANDARD**

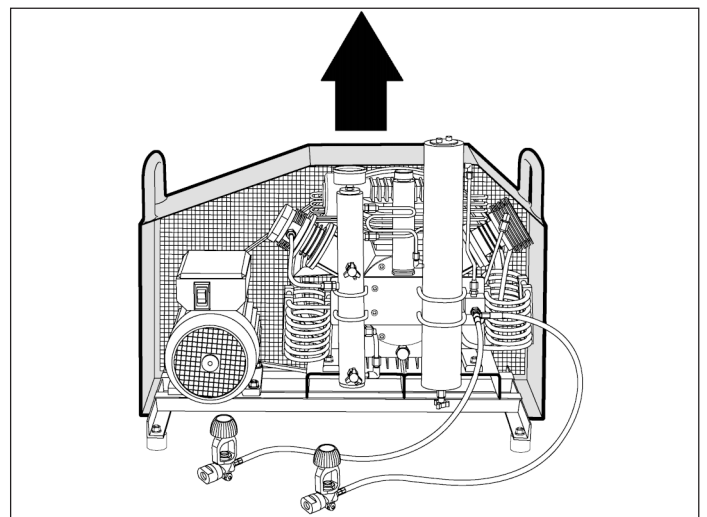

**MCH 8/EM STANDARD  
MCH 13-16/ET STANDARD**

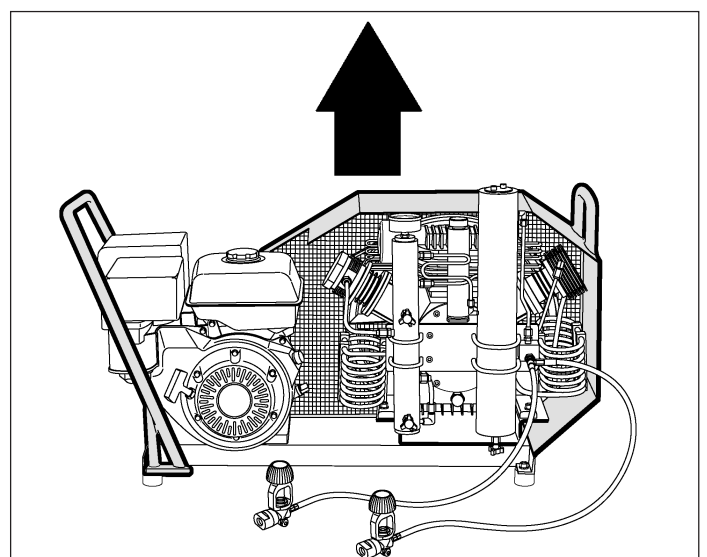

**MCH 13-16/SH  
MCH 13-16/DY  
MCH 13-16/DH**

- 2 By exerting a pressure of at least 5 Kg., check that the belt does not yield by more than 5 mm. compared to its original position

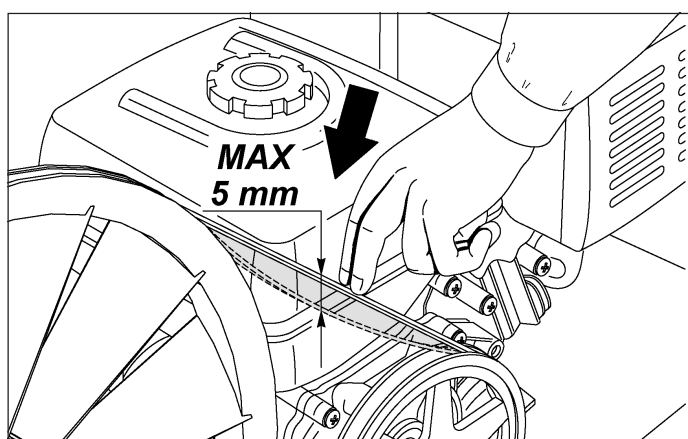
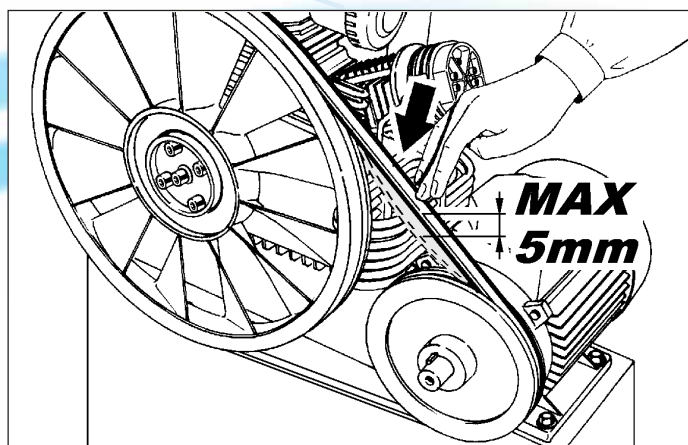

If this distance should exceed 5 mm., intervene by loosening the motor fastening screws (Fig. 122-123), remove the drive belt and move the motor away from the compressor by a few millimetres by sliding it along the slots.

Tighten the motor fastening screws.

Refit the belt, placing it in the race provided in the motor pulley and in the innermost race of the fan, turning it by hand to enable the belt to go over the diameter of the fan and to fit into the race.

- 3 Carry out the measurement procedure again and if necessary, repeat the operations until a maximum distance of 5 mm. is reached.
- 4 Replace the covers securing the appropriate screws tightly (see point 1).

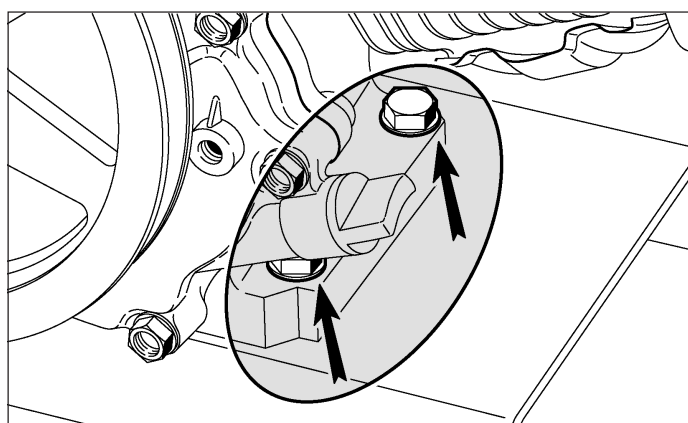
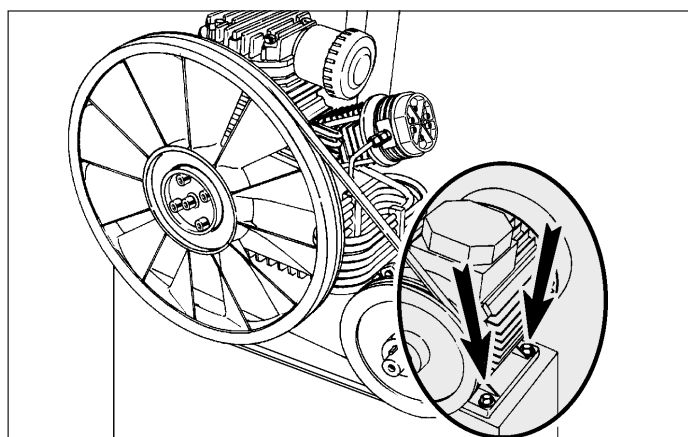

## AIR INTAKE FILTER

The intake filter must be checked to make sure it is in good order every 25 operating hours.

The filter is cleaned by blowing air inside the cartridge when it has been removed.

Replace the cartridge turning it by 60° compared to its initial position.

The filter must be replaced every 125 operating hours with the following procedure:

### MCH 13-16/ETC Standard

- 1 Remove the protection guard by unscrewing the fastening screws.

**NOTE:** for all the other models it is not necessary to remove the protection guard.

MCH 13-16/ETC Standard

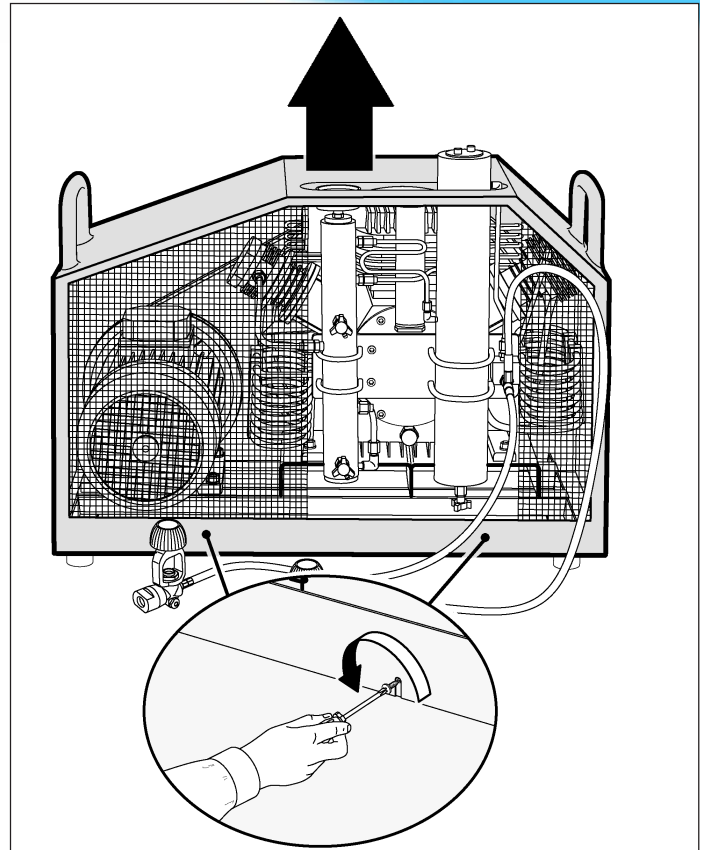

- 2 Press cap n° 1 lightly and turn it in an anti-clockwise direction.

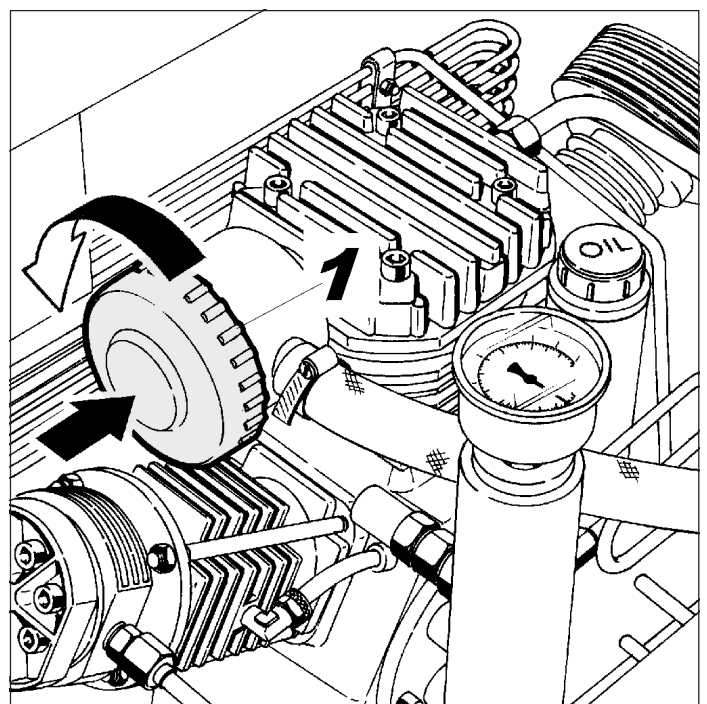

3 Remove the filter and replace it with a new one.

To order a new spare filter, refer to chapter 14 "Spare parts".

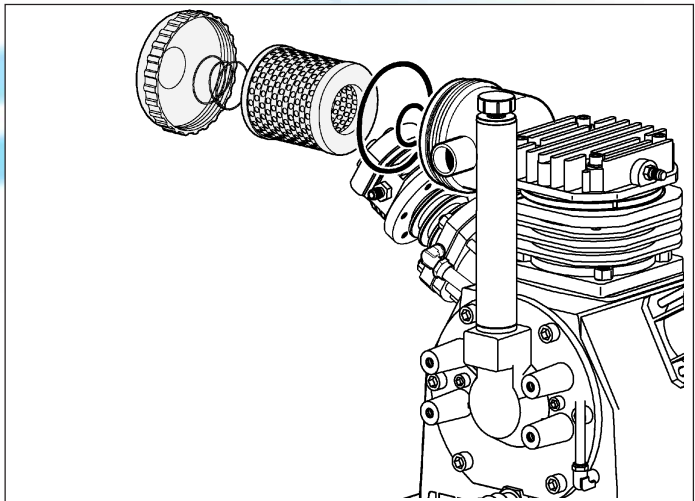

4 Replace the protection guards if they were removed securing them in place with the screws provided (see point 1).

**FACTIVATED CARBON FILTER AND MOLECULAR SIEVE**

The cartridges must be replaced before the air becomes foul-smelling.

The quality of the air depends to a large extent on the condition of the filtering cartridge. For this reason, it is important to comply with the intervals as specified.

The frequency of replacement has been calculated for use of the compressor with intake air at a temperature of 20 °C (68 °F), see table 4. If the temperatures differ, apply the coefficients given in the following table 3 to the duration of the filter :

**Table 3**

°C	°F	Multiplication coefficients
50	122	0.20
40	104	0.34
30	86	0.57
20	68	1
10	50	1.85
5	41	2.60
0	32	3.80

Table 4

MODEL	N° OF 10 LITRE CYLINDERS TO BE FILLED		VOLUME OF FILTERED AIR cu.m.	DURATION OF THE FILTER hours
	200 bar	300 bar		
MCH 8/EM	322	214	644	80
MCH 13/ETC	322	214	644	50
MCH 16/ETC	322	214	644	50
MCH 13/ET	322	214	644	50
MCH 16/ET	322	214	644	50
MCH 13/SH	322	214	644	50
MCH 16/SH	322	214	644	50
MCH 13/DY	222	214	644	50
MCH 16/DY	222	214	644	50
MCH 13/DH	322	214	644	50
MCH 16/DH	322	214	644	50

Check the sealing O-Rings and replace them if they are damaged.

Leave the cartridge in the filter when the compressor is not in use.

Maintain a pressure of 40-70 bar inside the filter to prevent outside damp from getting in.

To replace the activated carbon filter, proceed as follows:

- unscrew the external cap using a lever between the screws "A".

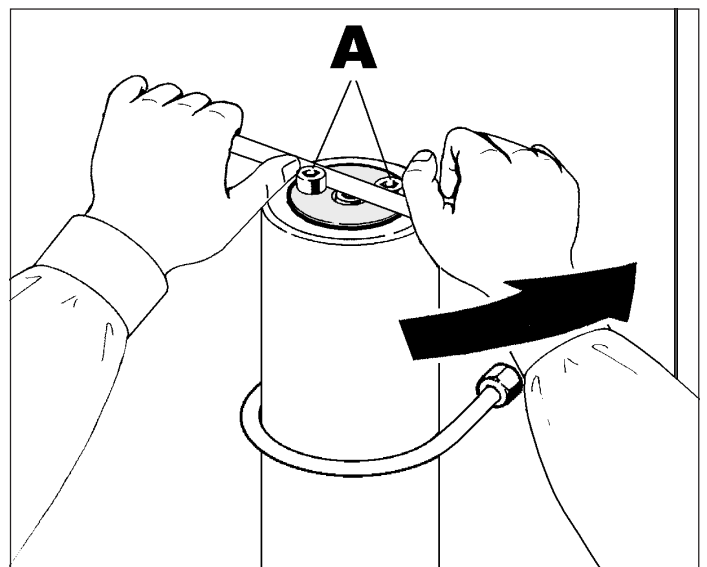

- remove the external cap and the internal cap;

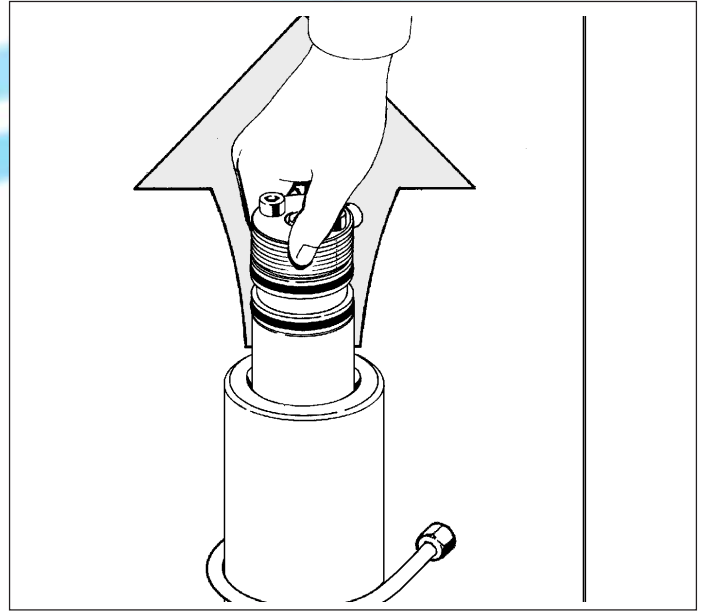

- unscrew the used cartridge from the internal cap and then screw in the new one;

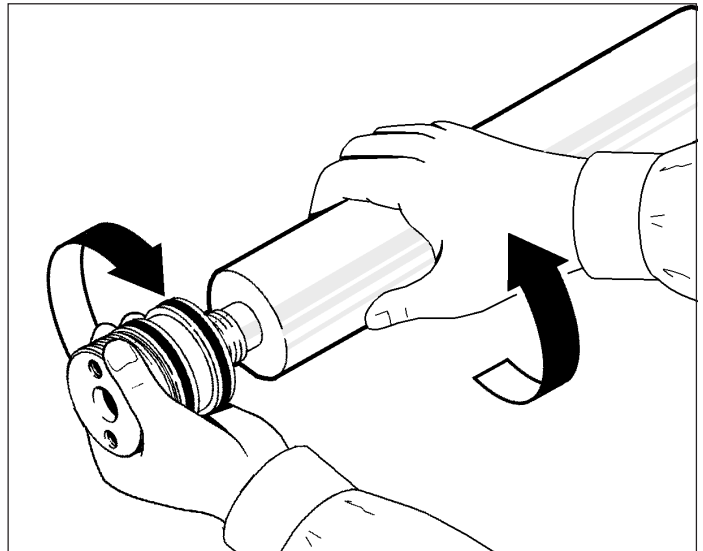

- screw up the internal cap having lubricated or replaced the sealing O-Rings if they are worn and having lubricated the threads of the external cap using silicone grease.

**WARNING**

The used activated carbon filter cannot be disposed of together with urban waste. To dispose of it, follow the instructions given in chapter 10.2, "Disposal of waste products" with great care.



**FILLING HOSE**

The filling hose must be in good condition especially in the area of the connections.

The plastic sheath that covers the hose must not show any signs of abrasion otherwise if any humidity infiltrates, it could corrode the steel plait and reduce its resistance. The hose must be replaced periodically (annually) and/or when it shows signs of wear. Failure to comply with this regulation could cause serious danger to the operators.

Make sure that the minimum radius of curvature of the hose is not less than 250 mm. To connect the hose, follow the instructions given in chapter 6.2.2, "Connecting the filling hose".

## INLET AND DISCHARGE VALVES

The 2<sup>nd</sup> stage inlet valve can be removed for maintenance purposes while those of the 1<sup>st</sup>, 2<sup>nd</sup> (only discharge) and 3<sup>rd</sup> stages must be entirely replaced. The seats must be cleaned carefully using petrol and soft brass or nylon brushes.

The torque wrench setting for the head bolts of the 3<sup>rd</sup> stage is initially 1 Kgm. Having moved the head closer, tighten the bolts to 2.2 Kgm, making sure that the piston is at the bottom dead centre during the operation.

Avoid using steel brushes or screwdrivers. The interval between maintenance operations is 400-600 working hours. If any parts are damaged or worn, they must be replaced. The discharge valves can be removed from the outside while the inlet valves can only be removed when the head of the cylinder has been taken off.

**NOTE:** the valve replacement procedure must be carried out at the work bench by specialized technicians who have specific equipment for the stripping operation.

In any case, it is preferable to contact **AEROTECNICA COLTRI S.r.l.** who will supply the necessary technical assistance.

## VALVE HEADS

- The head of the 1<sup>st</sup> stage (A) is of the lamellar type. It must be fitted so that the word "TOP" remains upwards and the flaps correspond with the openings in the cover of the head. Replace every 1000 hours.

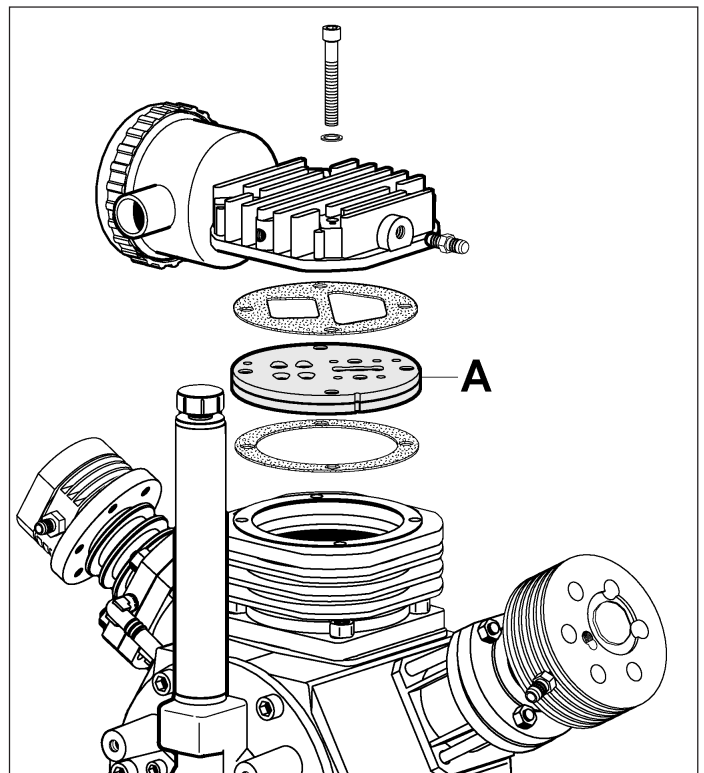

- The head of the 2<sup>nd</sup> stage (B) is made of aluminium, the valves are screwed in; the inlet valve inside is removed using a special pin wrench while the discharge valve is on the outside and is removed with a non-adjustable wrench or a box wrench.

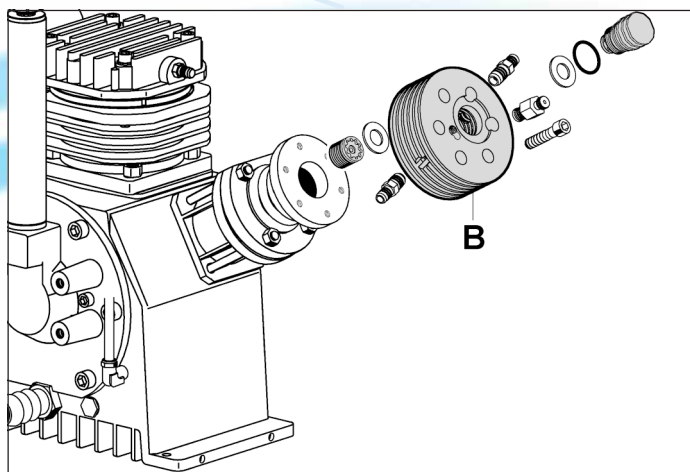

- The head of the 3<sup>rd</sup> stage (C) is made of aluminium, the inlet valve is screwed inside and is removed using a special pin wrench while the discharge valve is on the outside and is kept in position by the threaded dowel which is screwed into the cover.

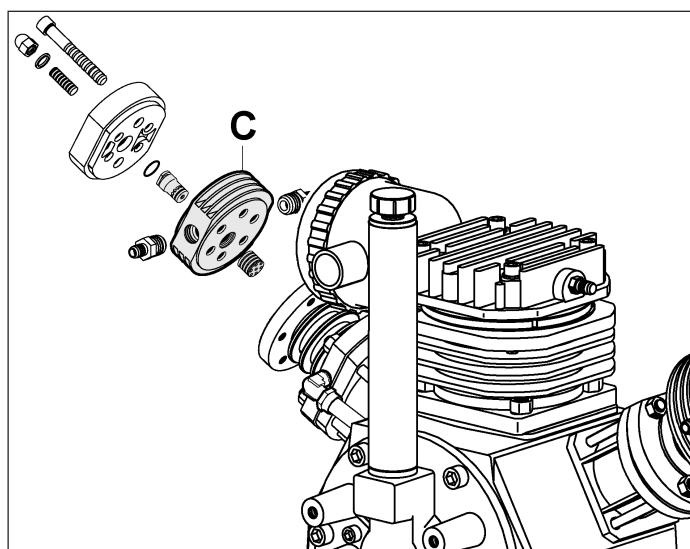

## CYLINDERS

After removing the cylinders, it is necessary to check, when they are replaced, that the piston at the maximum point and the upper edge of the cylinder are on the same level.

Adjust any differences that there may be by making the base of the cylinder thicker using gaskets.

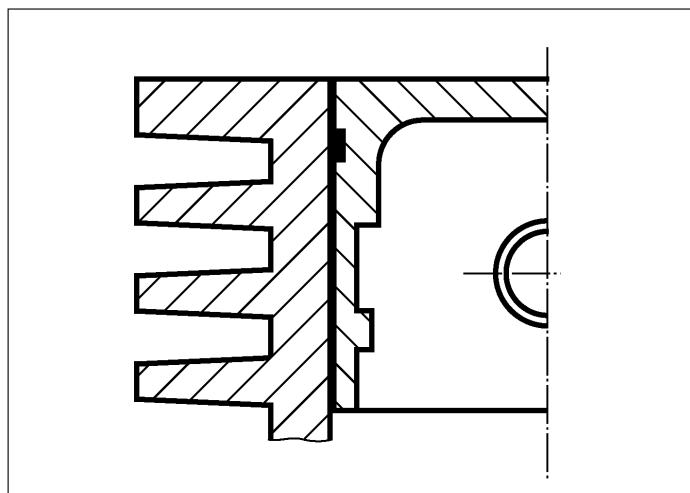

## INTERNAL COMBUSTION ENGINES

The compressors are supplied with an instruction manual compiled by the engine manufacturer. In case of doubt or for further information, refer to the specific engine manual.

### WARNING

Carry out all the operations described below either with the engine turned off or cold.



The intervals at which maintenance has to be carried out are shown in table 5.

## MAINTENANCE PROGRAMME

Table 5

INTERVAL FOR PERIODIC SERVICING To be carried out at the intervals or after the number of operating hours shown, whichever occurs first.		At each use	First month or 20 hours	Every 3 months or 50 hours	Every 6 months or 100 hours	Every year or 300 hours
UNIT	OPERATION					
Engine oil	Check level	○				
	Change		○	○		
Air filter	Check	○				
	Clean			○(1)	Replacement	
Sediment sump	Clean				○	
Spark plug	Check-clean				○	
Spark arrester (optional)	Clean	○				
Valve clearance	Check-adjustment					○(2)
Fuel tank and filter	Clean			○	Replacement	○(2)
Fuel pipes	Check (and replace if necessary)	Every two years (2)				
Battery	Check	○				

### NOTES:

- 1) Service more frequently in dusty areas.
- 2) These parts must be serviced by technical staff authorized by the manufacturer.

## OIL CHANGE

To ensure that all the oil is discharged, empty it out when the engine is hot.

Remove the oil top up cap and the oil discharge cap to discharge the oil.

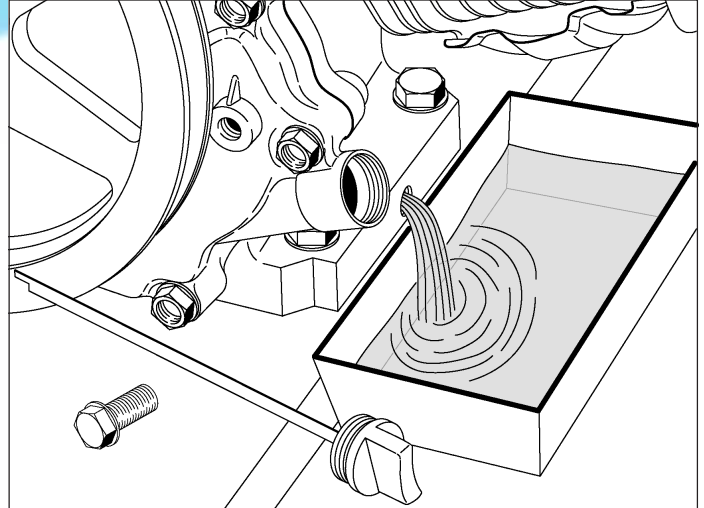

Screw up the oil discharge cap again and secure it tightly.

Top up with the type of oil recommended by the manufacturer and check.

Screw the oil top up cap.

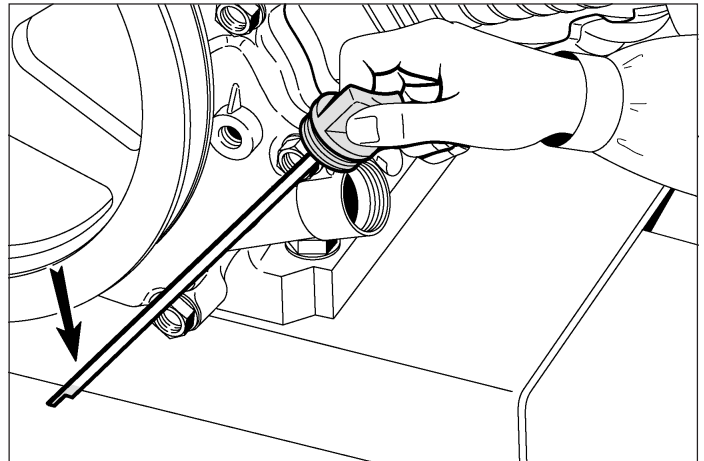

### DANGER

If the engine oil comes into constant contact with the skin, it can cause skin cancer. Although this is a very remote possibility except for those who handle engine oil every day, it is still advisable to wash hands well with soap and water as soon as possible after the work has been done.



### NOTE:

The used engine oil removed must be disposed of according to the national laws in force concerning such matters. We advise placing it in a sealed container and taking it to a service station for recycling.

### WARNING

The oil must be disposed of carefully and not into the environment (e.g. into wells, into the ground, etc.).



## AIR FILTER

If the air filter is dirty, it reduces the flow of air to the carburettor. To prevent damaging the carburettor, service the air filter regularly. It should be serviced even more frequently if the engine is used in very dusty areas.

### CAUTION

Never clean the air filter with petrol or very inflammable solvents, otherwise it could cause explosions or fires.

### WARNING

Never turn the engine on without the air filter as this would certainly damage it.

### PETROL ENGINE

- 1 Remove the butterfly nut and the air filter cover. Remove the filter parts and separate them. Check the parts carefully to ensure they are not perforated or damaged. If they are, replace them.

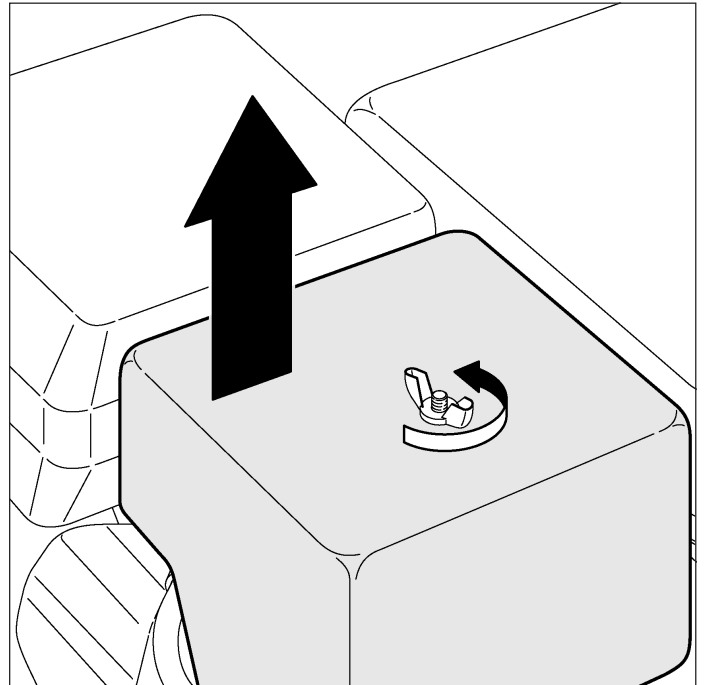

### DIESEL ENGINE

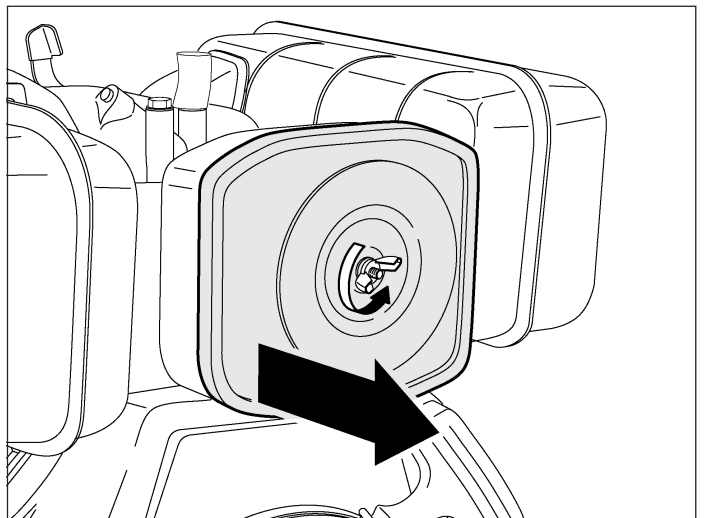

**PETROL ENGINE**

**2 Foam part :** wash the part in a cleansing solution for domestic use and hot water and dry well, or wash it in a solvent that is either not inflammable or only slightly inflammable. Then leave it to dry well. Soak the part in clean engine oil and squeeze it to get out all the excess oil.

**NOTE:**

if too much oil is left in the filter, the engine smokes in a strange way as soon as it is started up.

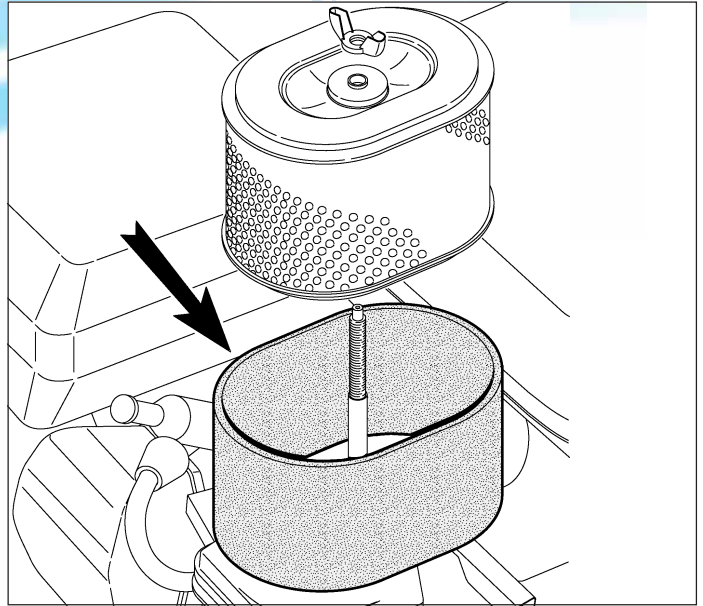

**DIESEL ENGINE**

**3 Paper part:** tap the part several times on a hard surface until the dirt is removed. Compressed air may also be blown into it from the inside outwards.

Never use brushes as they push the dirt into the fibres of the part. Replace the paper part if it is too dirty.

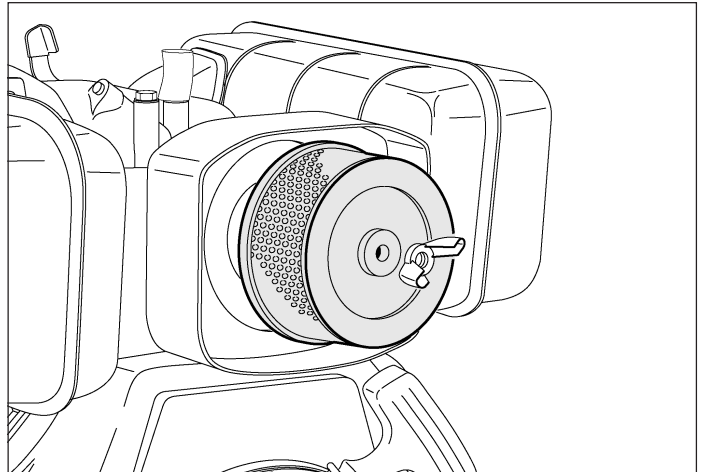

**SEDIMENT SUMP ( ONLY FOR  
PETROL ENGINES )**

**CAUTION**

- The fuel is highly inflammable and may even explode. Do not smoke in the surrounding area and do not allow naked flames or sparks near the engine.
- Once the sediment sump has been fitted, check that there are no leaks and that the whole area is free of any spilt fuel before starting the engine.



Move the fuel valve to "CLOSE". Remove the sediment sump and the "O" ring, then wash them in solvent that is either non-flammable or only slightly flammable. Leave them to dry well and then replace them. Open the fuel cock and check that it does not leak.

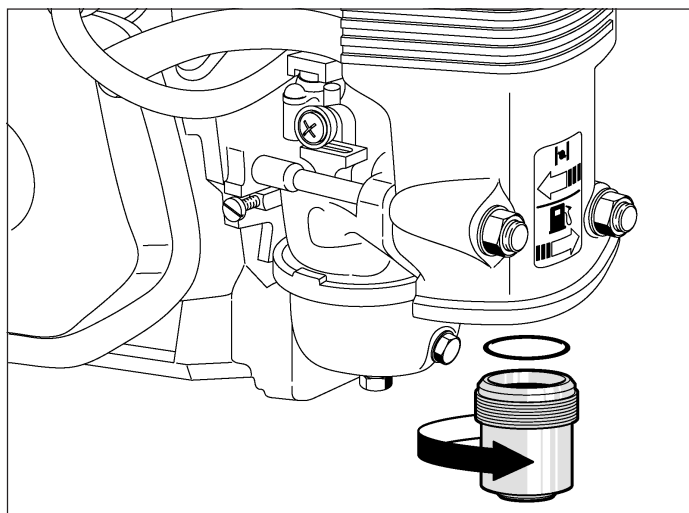
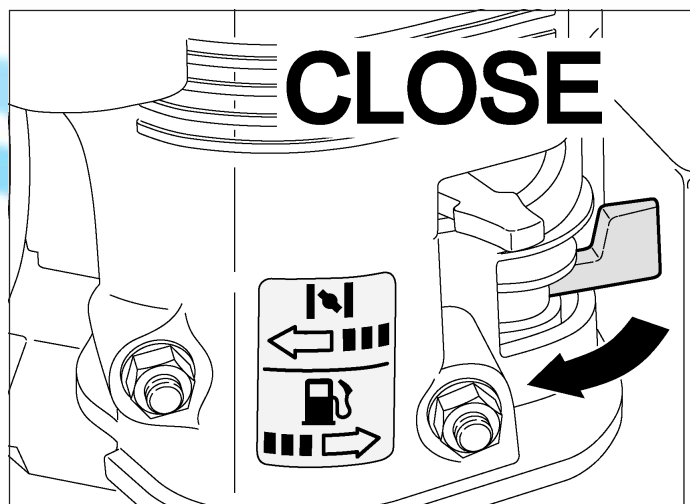

## SPARK PLUGS (ONLY FOR PETROL ENGINES)

### WARNING

Never use a spark plug with an unsuitable thermal range. In order for the engine to perform well, the spark plug must be clean and the electrodes must be at the right distance.

- 1 Remove the cap from the spark plug and use a spark plug key of the right size to remove the spark plug.

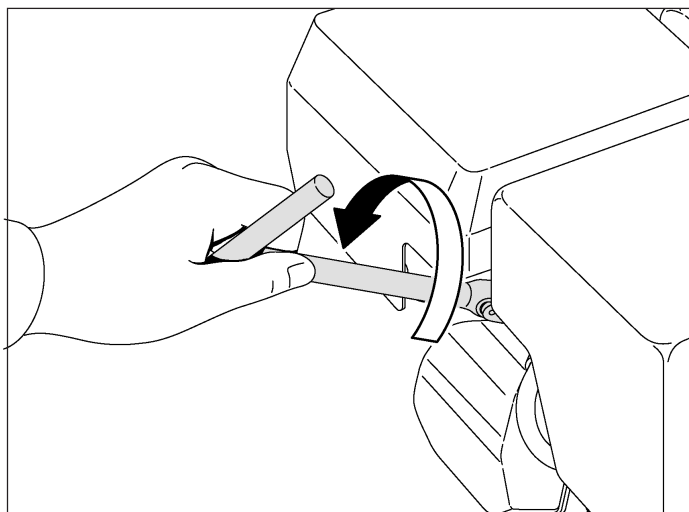

## WARNING

If the engine has been running, the silencer will be very hot. Take care not to get burnt.

- 2 Inspect the spark plug to check that it is not worn and that the insulator is not chipped or damaged. If the spark plug is worn or damaged, it must be replaced. Finally clean the spark plug with a steel brush.
- 3 Measure the distance between the spark plug electrodes using a thickness gauge, and correct it if necessary by bending the upper electrode.

The distance must be : 0.70 - 0.80 mm.

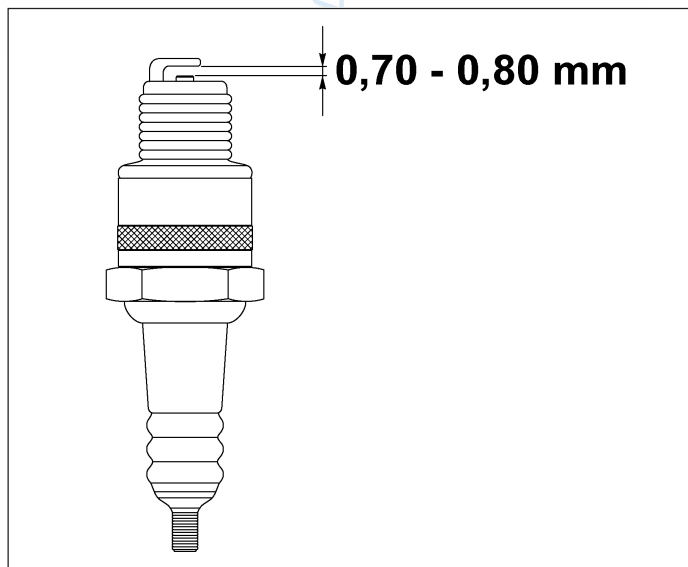

- 4 Check that the spark plug washer is in good condition. Screw in the spark plug by hand to avoid damaging the thread.
- 5 Once the spark plug rests on the base, tighten it with a key for spark plugs so that it squeezes the washer.

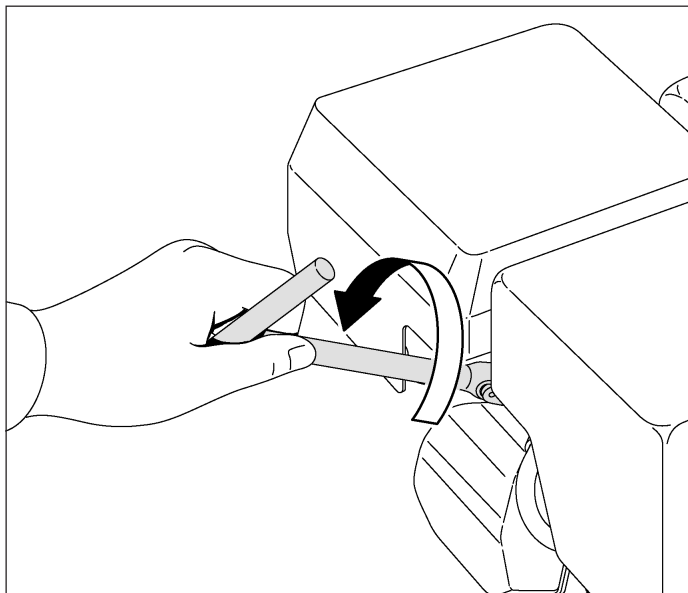

## NOTE:

When a new spark plug is fitted, tighten it by 1/2 a turn once it has been positioned so that it squeezes the washer. When a used spark plug is fitted again, tighten it by 1/8 – 1/4 of a turn until it has been positioned so that it squeezes the washer

## WARNING

The spark plug must always be tightly secured. If the spark plug is not tightened sufficiently, it may overheat and damage the engine.

## MINIMUM CARBURETTOR REGULATION (ONLY PETROL ENGINES)

Start up the engine and allow it to reach normal operating temperature.

Use the accelerator setscrew with the engine running at a minimum to achieve the standard minimum speed that is 1400÷150 r.p.m.

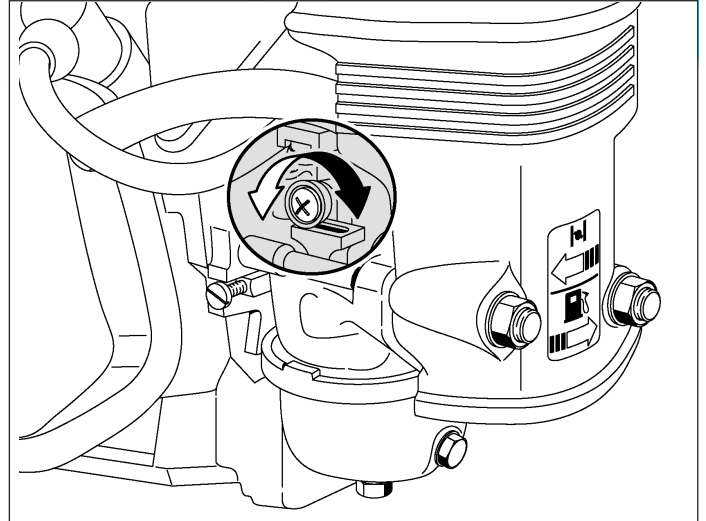

## FUEL FILTER

The fuel filter must be cleaned according to the intervals described (see Maintenance table); a regular engine performance depends on this.

To carry out this operation, proceed as follows:

- have a container suitable for holding the fuel nearby, of a sufficient capacity to contain the quantity of fuel;
- empty the fuel from the tank by unscrewing the discharge cap.

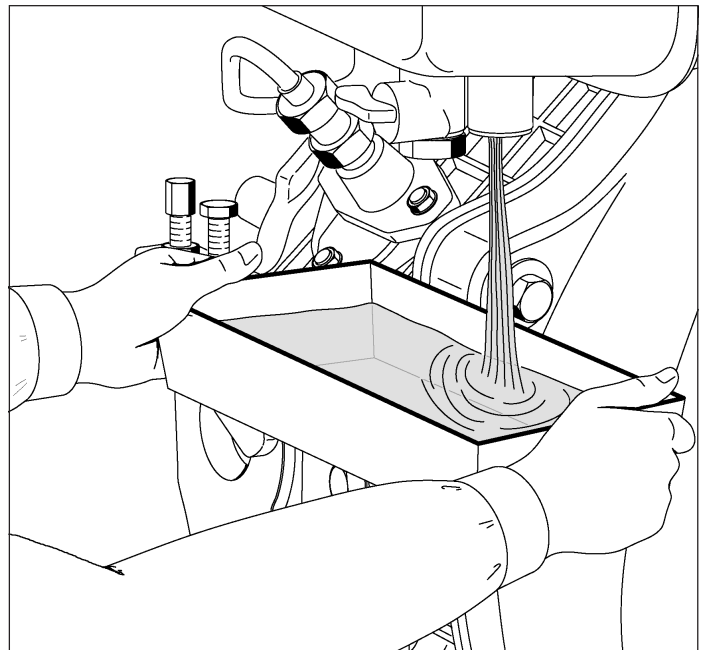

- Unscrew the carburettor cock clamp screws and remove the filter .

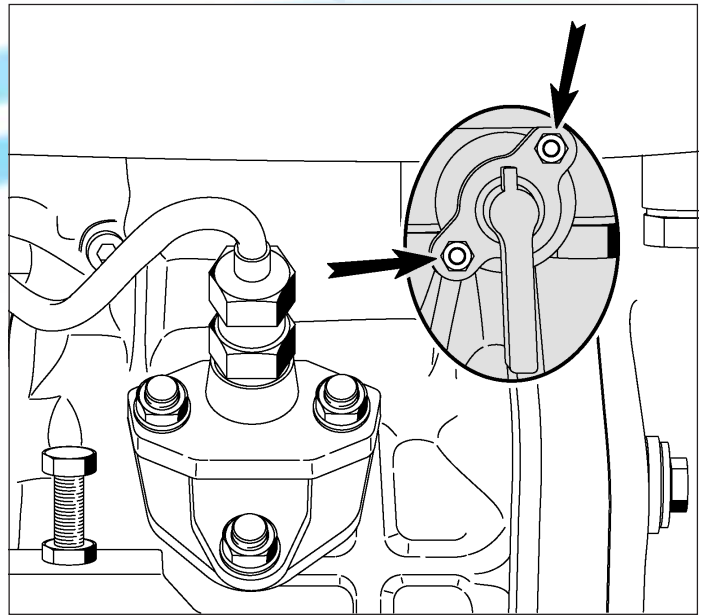

- Wash the filter with diesel oil and blow compressed air into it (if necessary replace it).
- Replace the filter, screw up the fuel cock and finally screw up the discharge cap once again.

## 12 VOLT BATTERY (NOT SUPPLIED BY AEROTECNICA COLTRI)

### CAUTION

- The electrolyte of the battery contains sulphuric acid; therefore, it is necessary to protect the eyes, skin and clothes. In the event of accidental contact, wash thoroughly with water and seek medical advice immediately, especially if the eyes are affected.
- The batteries emit hydrogen, a gas that can be highly explosive. Do not smoke and do not allow naked flames or sparks to come into contact with the battery, especially during the filling operation.

At each start up (daily), check the level of the electrolyte in the battery and the condition of the same.

If necessary top up. If there are any signs of damage, replace the battery.

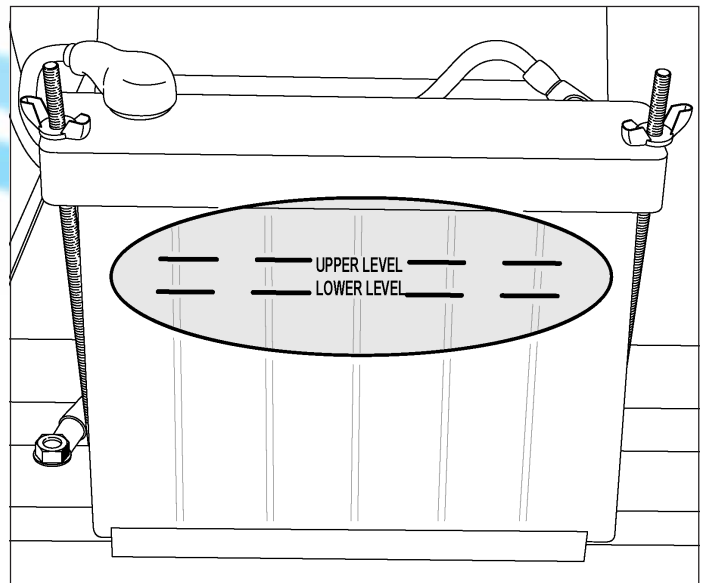

#### CAUTION

- Before the recharge, disconnect the same from the electric system otherwise the diodes will be damaged by the high voltage.
- Reconnect the positive (+) and the negative pole (-) of the battery according to the indications given on the battery itself. If the poles are inverted, the rectifier or the battery will be damaged.
- Before proceeding with the recharging, remove the caps from each part.
- Recharge the battery in a well-ventilated place.
- Do not proceed with the recharging if the temperature of the electrolyte exceeds 45 °C (127 °F).



**FIRST NEED SPARE PARTS LIST**

<b>LEVEL OF SERVICING DIFFICULTY</b>	SIMPLE	MEDIUM ● ●	DIFFICULTY
--------------------------------------	--------	---------------	------------

**TIME NEEDED**

**TOOLS NEEDED**

**SPECIAL TOOLS**

--	--	--	--

**7.1 PROGRAMMED  
MAINTENANCE**

SERVICE MANUAL

**COMPRESSOR TECHNICAL DATA SHEET**

<b>LEVEL OF SERVICING DIFFICULTY</b>	SIMPLE	MEDIUM ● ●	DIFFICULT
--------------------------------------	--------	---------------	-----------

**TIME NEEDED**

**TOOLS NEEDED**

**SPECIAL TOOLS**

--	--	--	--

## 8.1 PROGRAMMED MAINTENANCE

### 8.1.1 "STANDARD" SERIES COMPRESSORS

	MCH 8/EM	MCH 13/ETC	MCH 16/ETC	MCH 13/ET	MCH 16/ET	MCH 13/SH	MCH 16/SH	MCH 13/DY	MCH 16/DY	MCH 13/DH	MC 16/L
Max. non-continuous peak pressure	225 or 330 bar 3200 or 4700 psig										
Max. non-continuous working pressure	225 or 330 bar 3200 or 4300 psig										
Capacity	approx. 135 ltr/min 8 m <sup>3</sup> /h	approx. 260 ltr/min 16 m <sup>3</sup> /h	approx. 260 ltr/min 16 m <sup>3</sup> /h	approx. 520 ltr/min 32 m <sup>3</sup> /h	approx. 260 ltr/min 16 m <sup>3</sup> /h	approx. 210 ltr/min 13 m <sup>3</sup> /h	approx. 260 ltr/min 16 m <sup>3</sup> /h	approx. 210 ltr/min 13 m <sup>3</sup> /h	approx. 260 ltr/min 16 m <sup>3</sup> /h	approx. 210 ltr/min 13 m <sup>3</sup> /h	approx. 260 lb 16 m <sup>3</sup> /h
Cylinder diameter	88/36/14 mm	95/38/14 mm	95/38/14 mm	88/36/14 mm	95/38/14 mm	88/36/14 mm	95/38/14 mm	88/36/14 mm	95/38/14 mm	88/36/14 mm	95/38/14 mm
Speed of rotation	890 r.p.m.	1350 r.p.m.	1550 r.p.m.	1550 r.p.m.	1550 r.p.m.	1350 r.p.m.	1550 r.p.m.	1350 r.p.m.	1550 r.p.m.	1350 r.p.m.	1550 r
Piston stroke	40 mm										
Intermediate pressures	1 <sup>st</sup> stage 5 bar/70 psig 2 <sup>nd</sup> stage 40 bar/570 psig 3 <sup>rd</sup> stage 225-330 bar/3200-4700 psig										
Power motor	3kW - 4Hp Electric	4kW - 5.5Hp Electric	5.5kW - 7.5Hp Electric	4kW - 5.5Hp	5.5kW - 7.5Hp Petrol	6.6kW - 9Hp Petrol	6.6kW - 9Hp Petrol	6.6kW - 9Hp Diesel Yanmar	6.6kW - 9Hp	6.6kW - 9Hp Diesel	6.6kW - Horn
Tension and frequency	SINGLE PHASE 230V - 50Hz 230V - 60Hz										
	THREE-PHASE 400V - 50Hz 230V - 50Hz 230V - 60Hz 660V - 50Hz										

MODEL	Width A (mm)	Depth B (mm)	Height C (mm)	Weight (Kg.)
MCH 8/EM Standard	855	450	635	99
MCH 13/ETC Standard	855	475	665	126
MCH 16/ETC Standard	855	475	665	136
MCH 13/ET Standard	850	450	635	99
MCH 16/ET Standard	850	450	635	109
MCH 13-16/SH	1130	470	635	115
MCH 13-16/DY	1140	500	640	155
MCH 13-16/DH	1105	490	650	148

METHODS OF MEASUREMENT ISO 3746	MCH 8/EM Standard	MCH 13-16/ET Standard	MCH 13-16/ETC Standard	MCH 13-16/SH Standard	MCH 13-16/DY Standard	MCH 13-16/DH Standard
Level of acoustic pressure at the operator's work place	dB(A) 75,2	dB(A) 80,7	dB(A) 78,7	dB(A) 91,7	dB(A) 95,7	dB(A) 95,6
Level of acoustic power	dB(A) 88,0	dB(A) 93,2	dB(A) 91,2	dB(A) 106,2	dB(A) 109,2	dB(A) 109,1
Peak level	-	-	-	-	-	-
INSTRUMENTS						
Bruel & Kjacr sound level integrating meter	Mod. 2231 cl. 1					
Microphone for sound level meter	Mod. 4155 cl. 1					
Gauge	Mod. 4230 cl. 2					

8.1.2 "COMPACT" SERIES COMPRESSORS

	MCH 13/ET	MCH 16ET	MCH 26/ET	MCH
Max. non-continuous peak pressure	225 o 330 bar - 3200 o 4700 psi			
Max. non-continuous working pressure				
Capacity	approx. 210 lt/min 13 m <sup>3</sup> /h	approx. 260 lt/min 16 m <sup>3</sup> /h	approx. 420 lt/min 26 m <sup>3</sup> /h	approx. 520 lt
Cylinder diameter	88/36/14 mm	95/38/14 mm	88/36/14 mm	95/38/
Speed of rotation	1350 r.p.m.	1550 r.p.m.	1350 r.p.m.	1550
Piston stroke	40 mm			
Intermediate pressures	1 <sup>st</sup> stage 2 <sup>nd</sup> stage 3 <sup>rd</sup> stage	5 bar/70 psig 40 bar/570 psig 225-330 bar/3200-4700 psig	1 <sup>st</sup> stage 2 <sup>nd</sup> stage 3 <sup>rd</sup> stage	5 bar/70 psig 40 bar/570 psi 225-330 bar/3200-4700 psig
Power motor	4Kw-5,5HP	5,5Kw-7,5HP	2x 4Kw-5,5HP	2x 5,5K
Tension and frequency (three-phase)	400V - 50Hz 440V - 60Hz 230V - 50Hz 230V - 60Hz			

<b>MODEL</b>	<b>Width A (mm)</b>	<b>Depth B (mm)</b>	<b>Height C (mm)</b>	<b>Weight (Kg.)</b>
MCH 13/ET Compact	890	600	840	141
MCH 16/ET Compact	890	600	840	151
MCH 26/ET Compact	890	850	1330	286
MCH 32/ET Compact	890	850	1330	306

<b>METHODS OF MEASUREMENT ISO 3746</b>	<b>MCH 13/ET Compact</b>	<b>MCH 16/ET Compact</b>	<b>MCH 26/ET Compact</b>	<b>MCH 32/ET Compact</b>
Level of acoustic pressure at the operator's work place	dB(A) 79,4	dB(A) 81	dB(A) 72,4	dB(A) 75
Level of acoustic power	dB(A) 91,5	dB(A) 94,5	dB(A) 92,7	dB(A) 97,1
Peak level	-	-	-	-
<b>INSTRUMENTS</b>				
Bruel & Kjacr sound level integrating meter	Mod. 2231 cl. 1			
Microphone for sound level meter	Mod. 4155 cl. 1			
Gauge	Mod. 4230 cl. 2			

## 8.1.3 "MINI SUPER SILENT" SERIES COMPRESSORS

	MCH 13 ETS	MCH 16 ET
Max. non-continuous peak pressure	330 bar/4800 psig	
Max. non-continuous working pressure	330 max bar/4800 psig	
Capacity	approx. 215 lt/min 7.1 cfm	approx. 265 lt/min
Cylinder diameter	88/36/14 mm	95/38/14 mm
Speed of rotation	1350 r.p.m.	1550 r.p.m.
Piston stroke	40 mm	
Intermediate pressures	1 <sup>st</sup> stage 5 bar/70 psig 2 <sup>nd</sup> stage 40 bar/570 psig 3 <sup>rd</sup> stage 225-330 bar/3200-4800	
Power motor	4Kw-5,5HP	5,5Kw-7,5HP
Tension and frequency	400V - 50HZ 440V - 60HZ 230V - 50HZ 230V - 60HZ	

<b>MODEL</b>	<b>Width A (mm)</b>	<b>Depth B (mm)</b>	<b>Height C (mm)</b>	<b>Weight (Kg.)</b>
MCH 13/ETS Mini Silent	620	700	1050	177
MCH 16/ETS Mini Silent	620	700	1050	187
MCH 13/ETS Super Silent	870	900	1370	212
MCH 16/ETS Super Silent	870	900	1370	222

<b>METHODS OF MEASUREMENT ISO 3746</b>	<b>MCH 13/ETS Mini Silent</b>	<b>MCH 16/ETS Mini Silent</b>	<b>MCH 13/ETS Super Silent</b>	<b>MCH 16/ETS Super Silent</b>
Level of acoustic pressure at the operator's work place	dB(A) 71,9	dB(A) 74,5	dB(A) 66,2	dB(A) 68,8
Level of acoustic power	dB(A) 92,1	dB(A) 95,1	dB(A) 80,7	dB(A) 85,1
Peak level	-	-	-	-
<b>INSTRUMENTS</b>				
Bruel & Kjacr sound level integrating meter	Mod. 2231 cl. 1			
Microphone for sound level meter	Mod. 4155 cl. 1			
Gauge	Mod. 4230 cl. 2			

	MCH 13/ETC	MCH 16/ETC
Max. non-continuous peak pressure	225 or 330 bar 3200 or 4700 psig	
Max. non-continuous working pressure		
Capacity	approx. 210 lt/min 13 m <sup>3</sup> /h	approx. 260 lt/min 16 r
Cylinder diameter	88/36/14 mm	95/38/14 mm
Speed of rotation	1350 r.p.m.	1550 r.p.m.
Piston stroke	40 mm	
Intermediate pressures	3° Stage	225-330 bar/3200 - 4700
Power motor	4kW - 5,5Hp Electric	5,5kW - 7,5Hp Electric
Tension and frequency (three-phase)	400V - 50Hz 230V - 50Hz 230V - 60Hz	

MODEL	Width A (mm)	Depth B (mm)	Height C (mm)	Weight (Kg.)
MCH 13/ET Open	850	550	785	157
MCH 16/ET Open	850	550	785	167

METHODS OF MEASUREMENT ISO 3746	MCH 13/ET Open	MCH 16/ET Open
Level of acoustic pressure at the operator's work place	dB(A) 79,8	dB(A) 81,4
Level of acoustic power	dB(A) 94,5	dB(A) 97,5
Peak level	-	-
INSTRUMENTS		
Bruel & Kjacr sound level integrating meter	Mod. 2231 cl. 1	
Microphone for sound level meter	Mod. 4155 cl. 1	
Gauge	Mod. 4230 cl. 2	

## 8.1.5 TABELLE CONVERSIONE BAR/PSI

## CONVERSION TABLE PSI-BAR

psi	bar	psi	bar	psi	bar	psi	bar	psi	bar
1	0,07	61	4,21	310	21,38	910	63	3.400	234
2	0,14	62	4,28	320	22,07	920	63	3.500	241
3	0,21	63	4,34	330	22,76	930	64	3.600	248
4	0,28	64	4,41	340	23,45	940	65	3.700	255
5	0,34	65	4,48	350	24,14	950	66	3.800	262
6	0,41	66	4,55	360	24,83	960	66	3.900	269
7	0,48	67	4,62	370	25,52	970	67	4.000	276
8	0,55	68	4,69	380	26,21	980	68	4.100	283
9	0,62	69	4,76	390	26,90	990	68	4.200	290
10	0,69	70	4,83	400	27,59	1.000	69	4.300	297
11	0,76	71	4,90	410	28,28	1.010	70	4.400	303
12	0,83	72	4,97	420	28,97	1.020	70	4.500	310
13	0,90	73	5,03	430	29,66	1.030	71	4.600	317
14	0,97	74	5,10	440	30,34	1.040	72	4.700	324
15	1,03	75	5,17	450	31,03	1.050	72	4.800	331
16	1,10	76	5,24	460	31,72	1.060	73	4.900	338
17	1,17	77	5,31	470	32,41	1.070	74	5.000	345
18	1,24	78	5,38	480	33,10	1.080	74	5.100	352
19	1,31	79	5,45	490	33,79	1.090	75	5.200	359
20	1,38	80	5,52	500	34,48	1.100	76	5.300	366
21	1,45	81	5,59	510	35,17	1.110	77	5.400	372
22	1,52	82	5,66	520	35,86	1.120	77	5.500	379
23	1,59	83	5,72	530	36,55	1.130	78	5.600	386
24	1,66	84	5,79	540	37,24	1.140	79	5.700	393
25	1,72	85	5,86	550	37,93	1.150	79	5.800	400
26	1,79	86	5,93	560	38,62	1.160	80	5.900	407
27	1,86	87	6,00	570	39,31	1.170	81	6.000	414
28	1,93	88	6,07	580	40,00	1.180	81	6.100	421
29	2,00	89	6,14	590	40,69	1.190	82	6.200	428
30	2,07	90	6,21	600	41,38	1.200	83	6.300	434
31	2,14	91	6,28	610	42,07	1.210	83	6.400	441
32	2,21	92	6,34	620	42,76	1.220	84	6.500	448
33	2,28	93	6,41	630	43,45	1.230	85	6.600	455
34	2,34	94	6,48	640	44,14	1.240	86	6.700	462
35	2,41	95	6,55	650	44,83	1.250	86	6.800	469
36	2,48	96	6,62	660	45,52	1.260	87	6.900	476
37	2,55	97	6,69	670	46,21	1.270	88	7.000	483
38	2,62	98	6,76	680	46,90	1.280	88	7.100	490
39	2,69	99	6,83	690	47,59	1.290	89	7.200	497
40	2,76	100	6,90	700	48,28	1.300	90	7.300	503
41	2,83	110	7,59	710	48,97	1.400	97	7.400	510
42	2,90	120	8,28	720	49,66	1.500	103	7.500	517
43	2,97	130	8,97	730	50,34	1.600	110	7.600	524
44	3,03	140	9,66	740	51,03	1.700	117	7.700	531
45	3,10	150	10,34	750	51,72	1.800	124	7.800	538
46	3,17	160	11,03	760	52	1.900	131	7.900	545
47	3,24	170	11,72	770	53	2.000	138	8.000	552
48	3,31	180	12,41	780	54	2.100	145	8.100	559
49	3,38	190	13,10	790	54	2.200	152	8.200	566
50	3,45	200	13,79	800	55	2.300	159	8.300	572
51	3,52	210	14,48	810	56	2.400	166	8.400	579
52	3,59	220	15,17	820	57	2.500	172	8.500	586
53	3,66	230	15,86	830	57	2.600	179	8.600	593
54	3,72	240	16,55	840	58	2.700	186	8.700	600
55	3,79	250	17,24	850	59	2.800	193	8.800	607
56	3,86	260	17,93	860	59	2.900	200	8.900	614
57	3,93	270	18,62	870	60	3.000	207	9.000	621
58	4,00	280	19,31	880	61	3.100	214	9.100	628
59	4,07	290	20,00	890	61	3.200	221	9.200	634
60	4,14	300	20,69	900	62	3.300	228	9.300	641

## Miscellaneous conversion table

### Linear measures

	cm	m	km	Zoll	Fuß	mile
cm	1	0.01	$1 \times 10^{-5}$	0.3937	0.03281	$6.21 \times 10^{-6}$
m	100	1	0.001	39.37	3.281	$6.21 \times 10^{-4}$
km	$1 \times 10^5$	1000	1	$3.94 \times 10^4$	3281	0.6214
in. (Zoll)	2.540	0.02540	$2.54 \times 10^{-5}$	1	0.08333	$1.58 \times 10^{-5}$
ft. (Fuß)	30.48	0.3048	$3.05 \times 10^{-4}$	12	1	$1.89 \times 10^{-4}$
mile	$1.61 \times 10^5$	1.609	1.609	$6.34 \times 10^4$	5280	1

### Volume measures

	cm <sup>3</sup>	liter	m <sup>3</sup>	(Zoll) <sup>3</sup>	(Fuß) <sup>3</sup>	gal
cm <sup>3</sup>	1	0.001	$1 \times 10^{-6}$	0.06102	$3.53 \times 10^{-5}$	$2.64 \times 10^{-4}$
liter	100	1	0.001	61.02	0.03532	0.2642
m <sup>3</sup>	$1 \times 10^6$	1000	1	$6.10 \times 10^4$	35.31	264.2
in. <sup>3</sup> (Zoll) <sup>3</sup>	16.39	0.01639	$1.64 \times 10^{-5}$	1	$5.79 \times 10^{-4}$	0.00433
ft. <sup>3</sup> (Fuß) <sup>3</sup>	$2.83 \times 10^4$	28.32	0.02832	1728	1	7.481
gal	3785	3.785	0.00379	231.0	0.1337	1

### Flow rates

	l/s	gal/min	ft <sup>3</sup> /s	ft <sup>3</sup> /min
l/s	1	15.85	0.03532	2.119
gal/min	0.06309	1	0.00223	0.1337
ft <sup>3</sup> /s	28.32	448.8	1	60
ft <sup>3</sup> /min	0.4719	7.481	0.01667	1

### Pressure conversion table

	mm Hg	inch Hg	inch H <sub>2</sub> O	ft H <sub>2</sub> O	atm	lb/in. <sup>2</sup>	kg/cm <sup>2</sup>
mm Hg	1	0.03937	0.5353	0.04460	0.00132	0.01934	0.00136
inch Hg	25.40	1	13.60	1.133	0.03342	0.04912	0.03453
inch H <sub>2</sub> O	1.868	0.07355	1	0.08333	0.00246	0.03613	0.00254
ft H <sub>2</sub> O	22.42	0.8826	12	1	0.02950	0.4335	0.03048
atm	760	29.92	406.8	33.90	1	14.70	1.033
lb/in. <sup>2</sup>	51.71	2.036	27.67	2.307	0.06805	1	0.07031
kg/cm <sup>2</sup>	735.6	28.96	393.7	32.81	0.9678	14.22	1



## **AEROTECNICA COLTRI S.r.l.**

*Sede legale:* Via Rio Ponale, 7 - 25010 Rivoltella di Desenzano D/Garda - BRESCIA - ITALIA

*Stabilimento con esposizione:* Via Colli Storici, 177 - 25010 San Martino della Battaglia - BRESCIA - ITALIA

Tel. 030 9910297-9910301 - Fax 030 9910283

e-mail: [coltrisub@coltrisub.it](mailto:coltrisub@coltrisub.it) Internet: <http://www.coltrisub.it>